



WWW.HSPUTELIDS.COM

1300 441 498

Part No: MX12

Fitting Time: 30 mins



# Mercedes-Benz X-Class

HSP TAIL ASSIST

---

FITTING INSTRUCTIONS

## —GENERAL NOTES

---

- Read through the fitting instructions prior to installation of accessory.
- Ensure all recyclable components and packaging are discarded and recycled following local recycling regulations.
- Safely store and protect any removed vehicle components.

## —SAFETY NOTES

---

- Check that all work practices comply with safety standards.
- Please wear appropriate clothing and use safety equipment.

## —FITTING TIME

---



30 mins

## —PARTS SUPPLIED

---

<b>PART NUMBER</b>	<b>PART DESCRIPTION</b>	<b>QUANTITY</b>
TRS-SPEC-1	Traction strut	1
KSD-SPEC-1	Dampener strut	1
TA-05LH	Tailgate mount l/h	1
TA-05RH	Tailgate mount r/h	1
TA-06LH	Tub mount l/h	1
TA-06RH	Tub mount R/h	1
	<b><u>Nuts &amp; bolts</u></b>	
47	M8 x 20mm button socket ss	2
24	M8 thick washer	2
40	M8 nyloc nut	2
	<b><u>Other</u></b>	
TR-320	CLEAR PROTECTION TAPE	2
	Alcohol wipe	1

— STEP 1 —

Open tailgate.

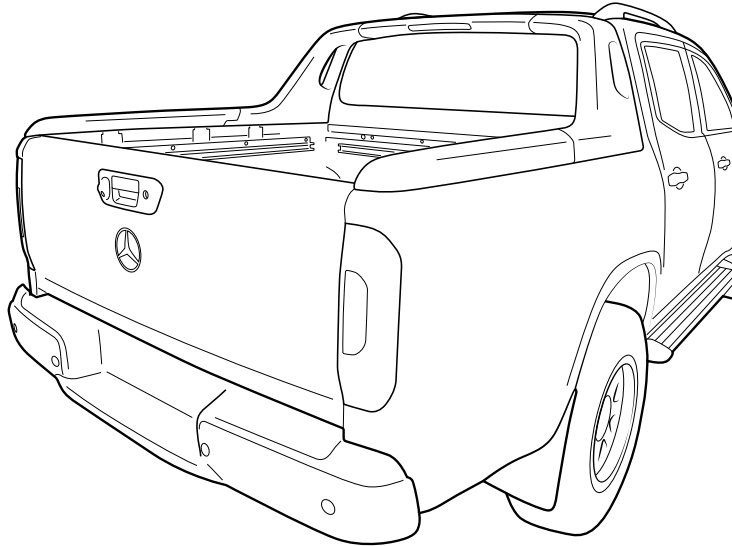

— STEP 2 —

Remove tail light and the indicated bolt ( retain bolt) repeat step on the passenger side.

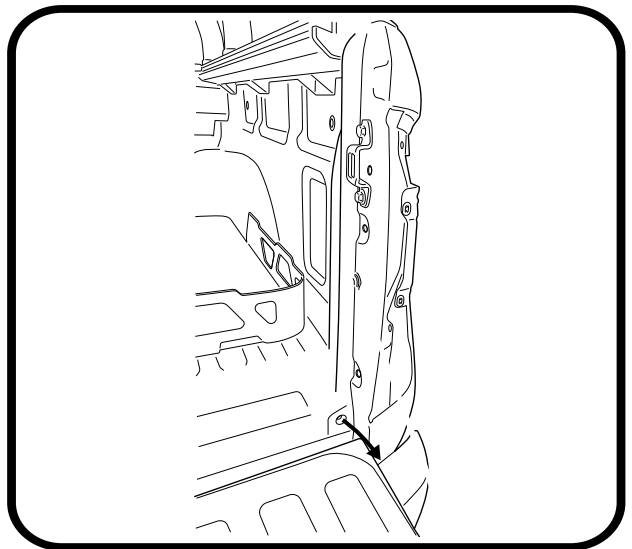
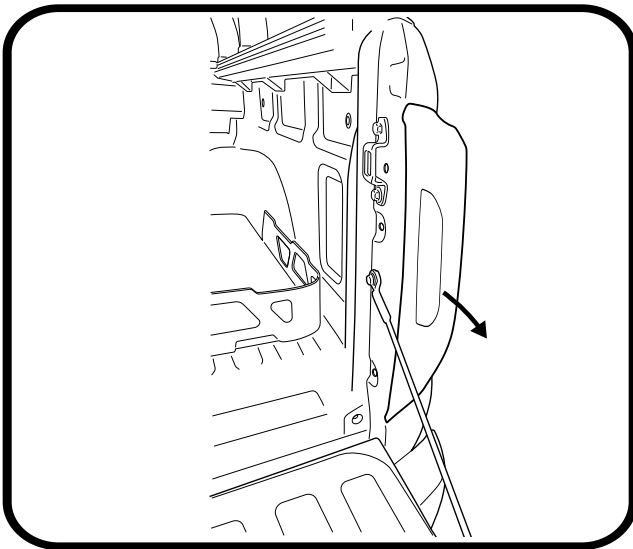

### —STEP 3—

Place part number TA-06RH ( Tub mount right hand) as indicated. Using the factory bolt retained, now secure in place. ⚠ (The bracket has an elongated hole, push the bracket down all the way before fastening)

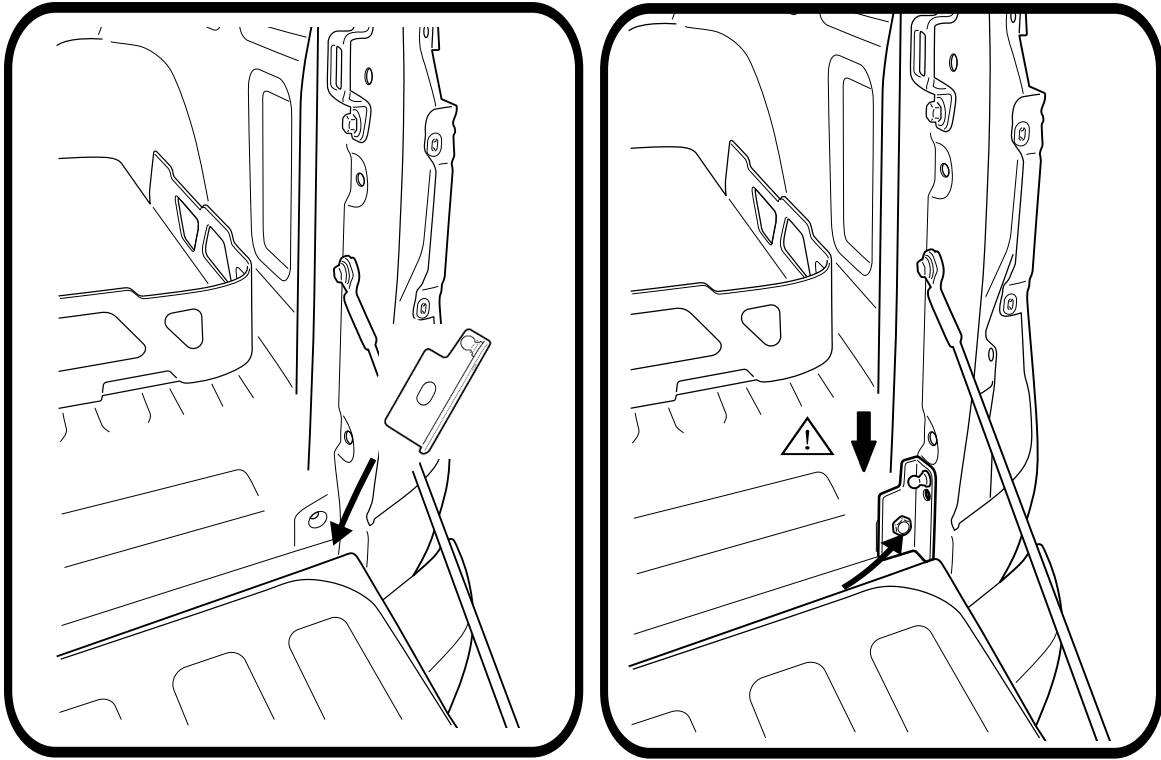

### —STEP 4—

The TA-06RH will have a pre drilled hole. Drill through a pilot hole it into the tub body ( using a 4mm drill bit ). Remove bracket TA-06, then drill through using 8mm drill bit, Clean surface & apply rust inhibitor.

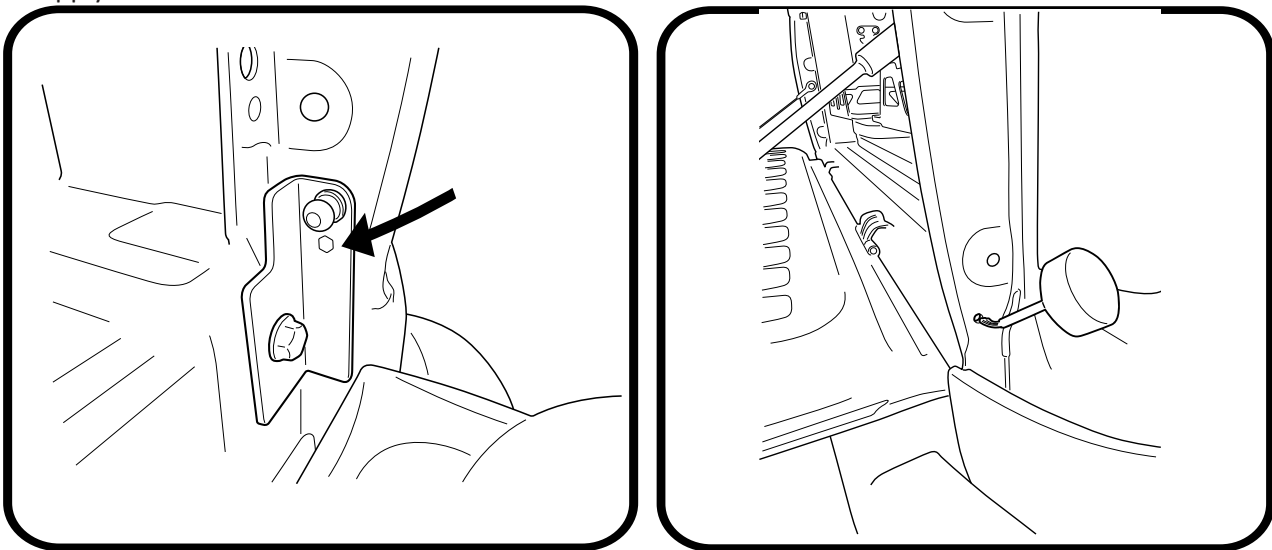

## — STEP 5 —

Place part number TA-06RH ( Tub mount right hand) as indicated. Using the factory bolt retained, now secure in place. (The bracket has an elongated hole, push the bracket down all the way before fastening). Now feed M8 x 20mm (Part number 40) button bolt supplied through the bracket (TA-06RH) followed by the 3mm thick washer (24) and ute body, fasten using the M8 nyloc nut provided (40).

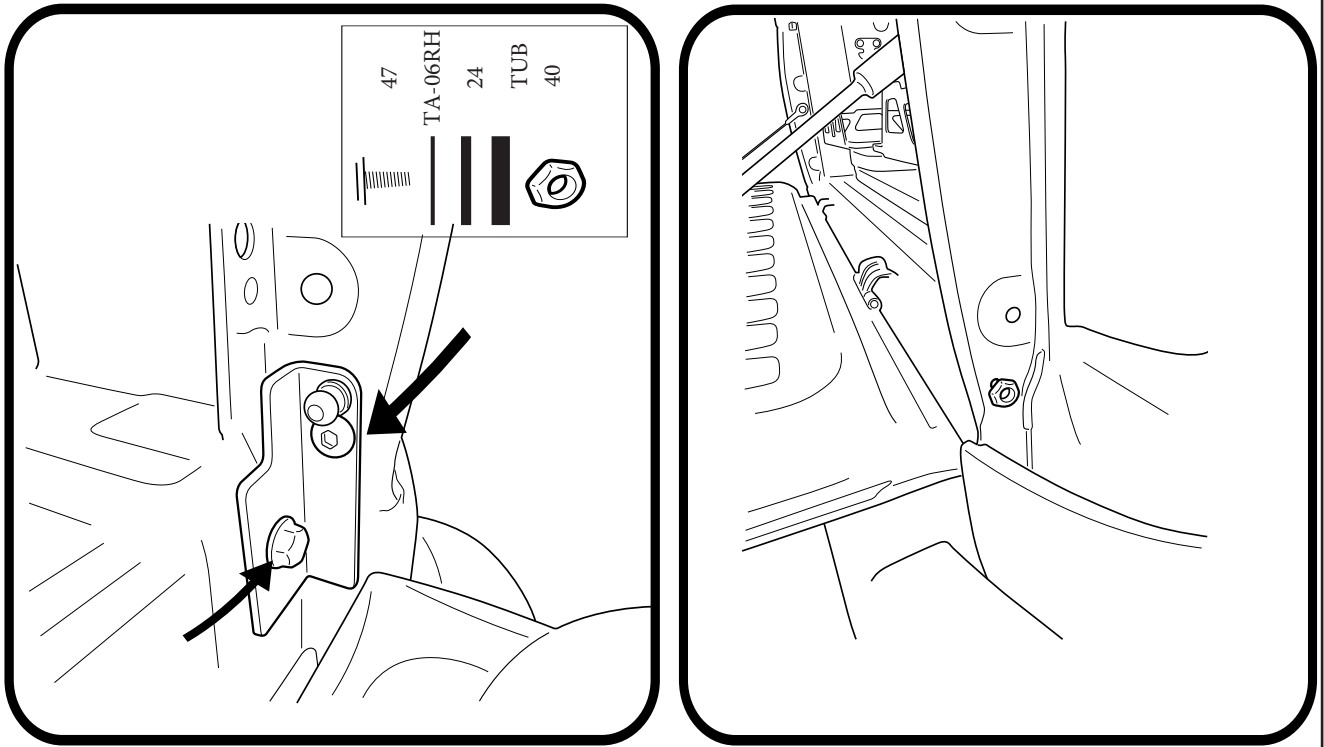

**! NOTE:** washer to be placed between the bracket and tub.

## — STEP 6 —

1. Remove indicated bolts and retain.
2. Remove and discard the plastic & steel washers.

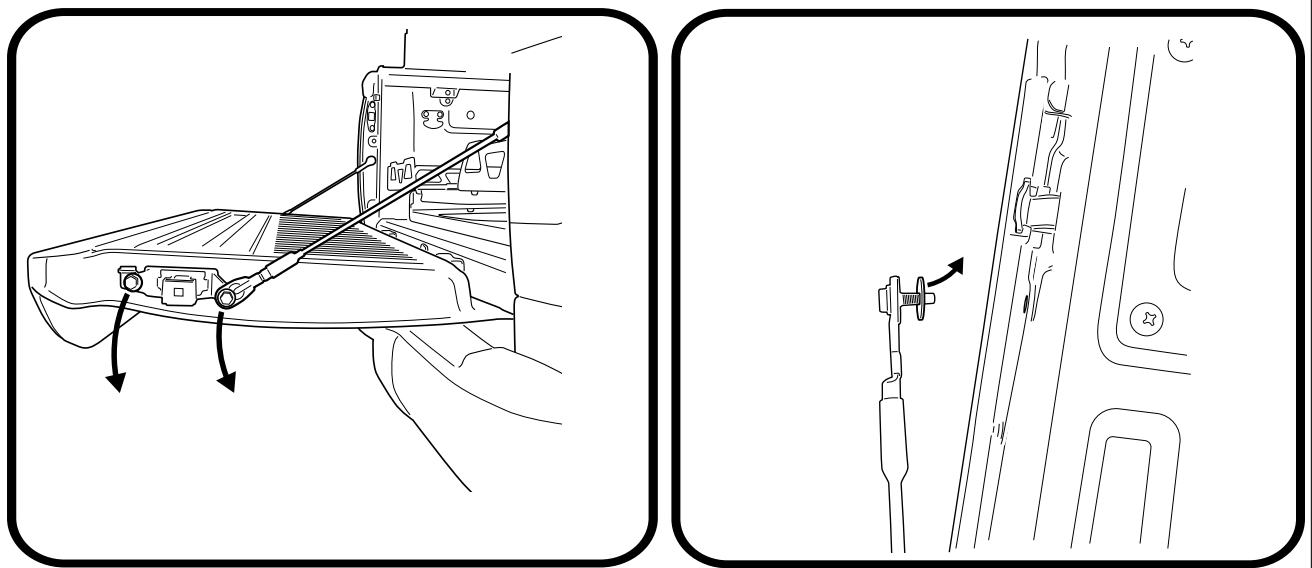

—STEP 7—

Place TA-05RH as indicated.

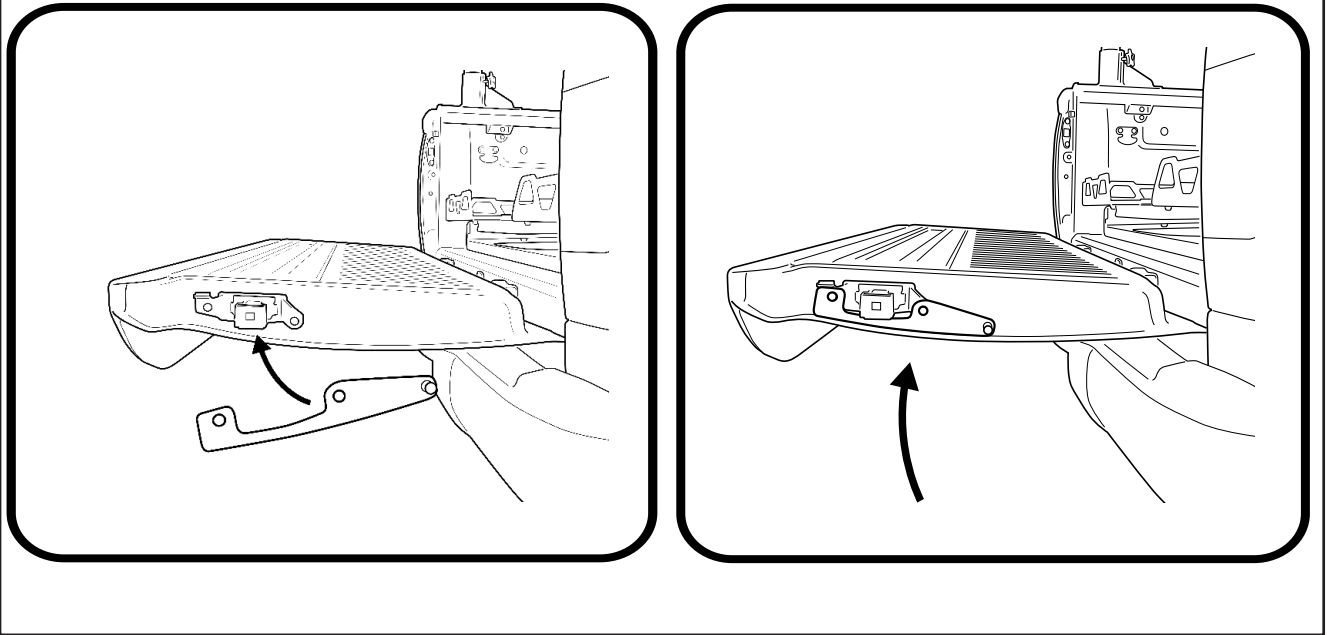

—STEP 8—

1. Fasten the bracket into place using the retained bolts.
2. Inspect the factory strap making sure it can move freely.
3. Apply clear protection tape ( TR-320) as indicated.

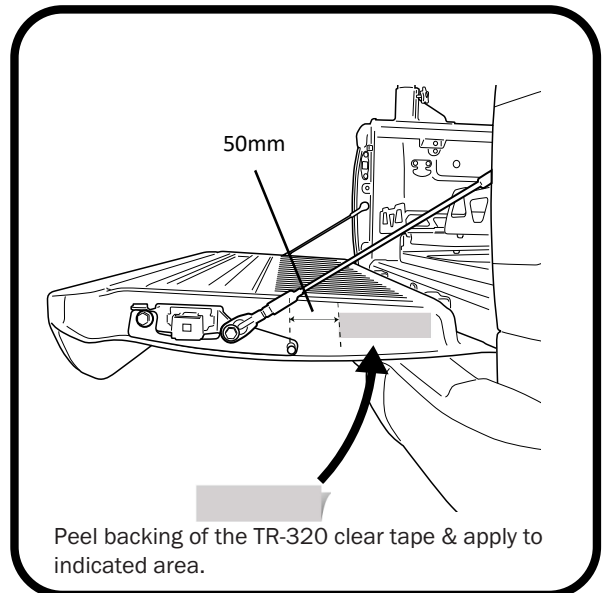
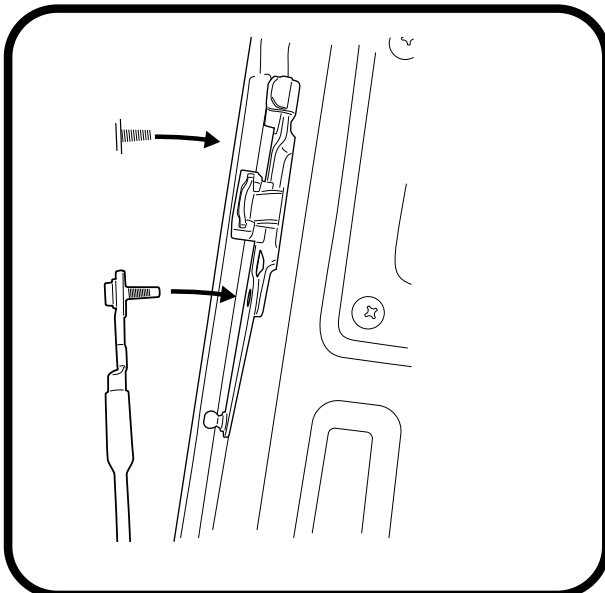

## — STEP 9 —

1. Connect part number KSD (Dampener strut) as indicated. You will need to pull on the shaft to extend and click in to position.
2. Re-fit the tail light on the drivers side.

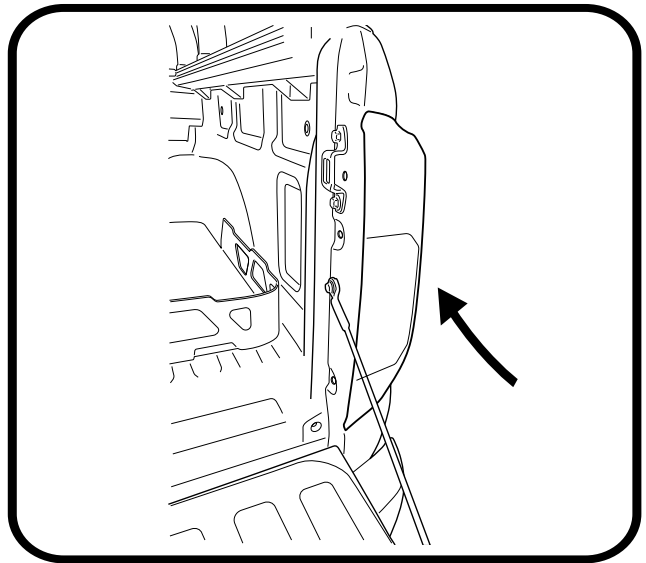
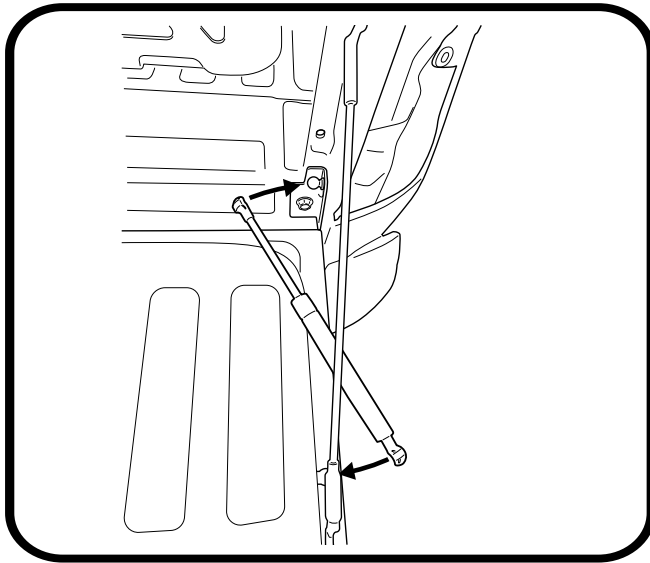

## — STEP 10 —

**Repeat all the above steps on the passenger side, using TA-05LH & TA06LH.**

NOTE: The passenger side Strut has a spacer which will need removing once installed.

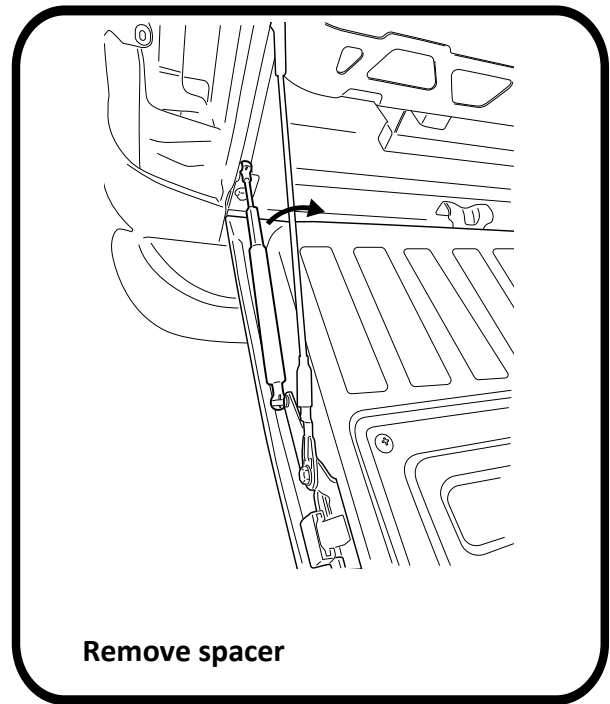
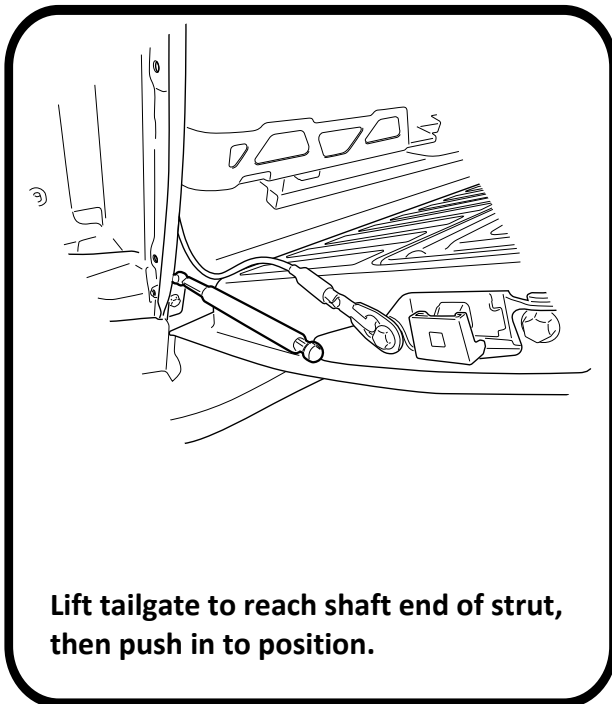

## — FITTING COMPLETE —