



INSTALLATION INSTRUCTIONS

**To suit Mitsubishi Triton MQ & MR
Dual cab.**



INSTALLATION TIME: 2 Hours (Approximately)

IMPORTANT	<ul style="list-style-type: none"> • Do not stand/sit or rest heavy objects on Roll R Cover • Humans or animals are not to be under the closed cover at any given time • Tonneau Cover is not dust or water tight • If contact with volatile chemicals occur, clean Cover with mild detergent and water solution 			
Care Instructions	<ul style="list-style-type: none"> • Read Instructions fully before commencing installation. • Clean Cover with a mild detergent and water solution • Do not use abrasive cleaners or solvents • Refer to manufactures instructions applicable to power drill. • Protect Tub floor against scratches during installation process. 			
Maintenance	Refer to Maintenance instructions.			
Tools Required	<table style="width: 100%; border: none;"> <tr> <td style="vertical-align: top;"> <ul style="list-style-type: none"> • Pen / Marker • Centre Punch • Drill & Drill bits • Caulking Gun • Silicon - Non Acetic </td> <td style="vertical-align: top;"> <ul style="list-style-type: none"> • Scissors & Knife • Spanner & Socket • Tape measure • Holesaw • Filing tool </td> <td style="vertical-align: top;"> <ul style="list-style-type: none"> • Soapy water solution • Allen Key set • Screw driver • Rust Inhibitor • Trim Removal Tool </td> </tr> </table>	<ul style="list-style-type: none"> • Pen / Marker • Centre Punch • Drill & Drill bits • Caulking Gun • Silicon - Non Acetic 	<ul style="list-style-type: none"> • Scissors & Knife • Spanner & Socket • Tape measure • Holesaw • Filing tool 	<ul style="list-style-type: none"> • Soapy water solution • Allen Key set • Screw driver • Rust Inhibitor • Trim Removal Tool
<ul style="list-style-type: none"> • Pen / Marker • Centre Punch • Drill & Drill bits • Caulking Gun • Silicon - Non Acetic 	<ul style="list-style-type: none"> • Scissors & Knife • Spanner & Socket • Tape measure • Holesaw • Filing tool 	<ul style="list-style-type: none"> • Soapy water solution • Allen Key set • Screw driver • Rust Inhibitor • Trim Removal Tool 		

PERSONAL PROTECTIVE EQUIPMENT:



Rubber Gloves



Goggles



Hearing Protection

BOX CONTENTS

LEFT & RIGHT SIDE RAIL

S2.5-DC-AE-002ps-Q4 

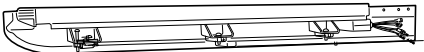
S2.5-DC-AE-003ds-Q4 



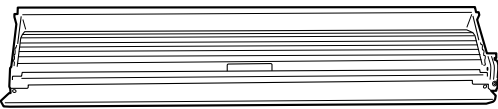





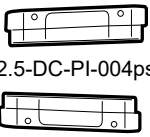

CANISTER ASSEMBLY

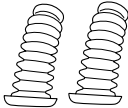
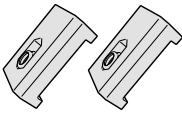
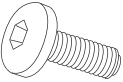

S3-DC-AF-Q4R-001-002

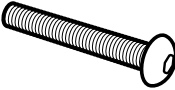
CANISTER TOP COVER  S2.5-DC-AE-005 -Q

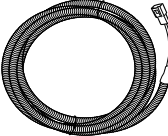
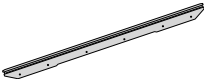
SPECIFIC KIT Q4R

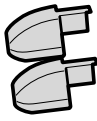
<p>COVER END CAPS</p>  <p>S2.5-DC-PI-004ps S2.5-DC-PI-004ds</p>	 <p>COUNTERSUNK SCREW Qty - 4</p>	 <p>FLAT PLATE Qty - 2</p>	 <p>CABLE TIE Qty x 16</p>	 <p>BATTERY LOOM S2.75</p>	 <p>Drainage pipe Qty - 2</p>
 <p>SIDERAIL CLAMP Qty - 6</p>	 <p>M8 x 35mm Qty - 6</p>	 <p>M8 WASHER Qty - 6</p>	 <p>M8 SPRING WASHER Qty - 6</p>	 <p>M8 x 90 mm Qty - 2</p>	 <p>M8 NUT Qty - 8</p>
 <p>Q-PATCH</p>	 <p>CL-LOOM-LONG</p>	 <p>FBA-Q4R</p>	 <p>3M PRIMER Qty - 1</p>	 <p>SIDERAIL TRACK ENDCAP Qty - 2</p>	

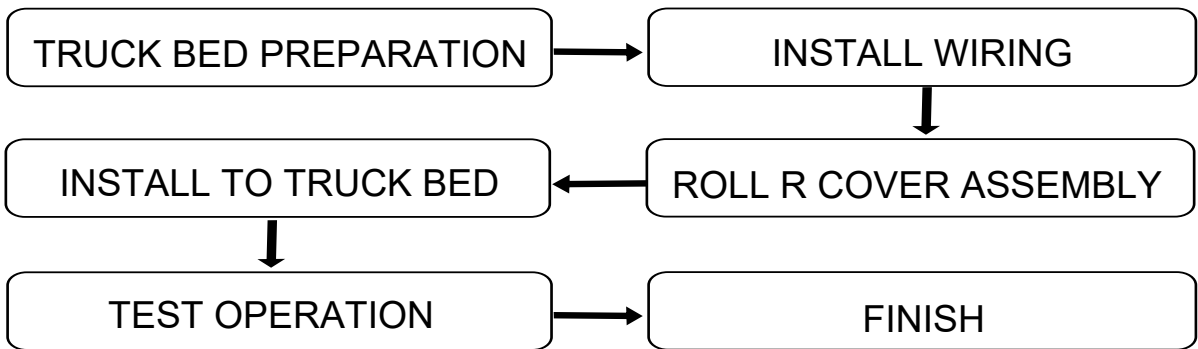

TUB PREPARATION

If the Vehicle is fitted with a cabin guard or sports styling bar, remove from Ute Tub (truck bed) including any bracket's holding it.

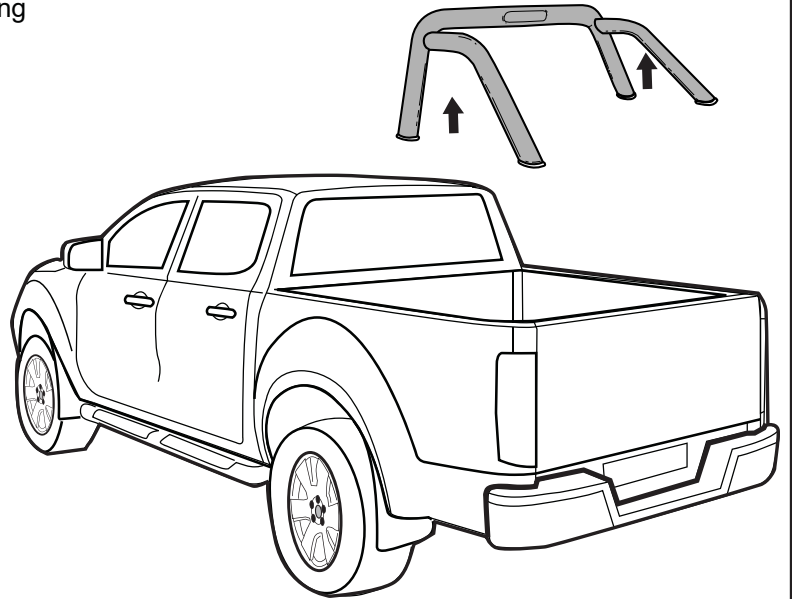

If ute bed is fitted with a headboard, Cut (cabin guard) head board and apply rust inhibitor.

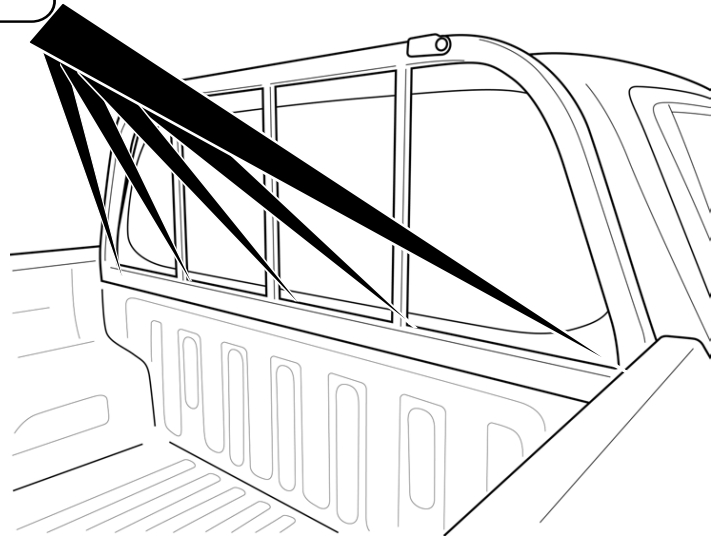
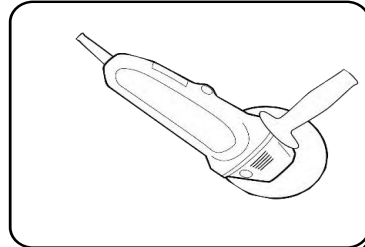

If the Vehicle is fitted with a cabin guard, remove from Ute Tub (truck bed).

Clean are as indicated.

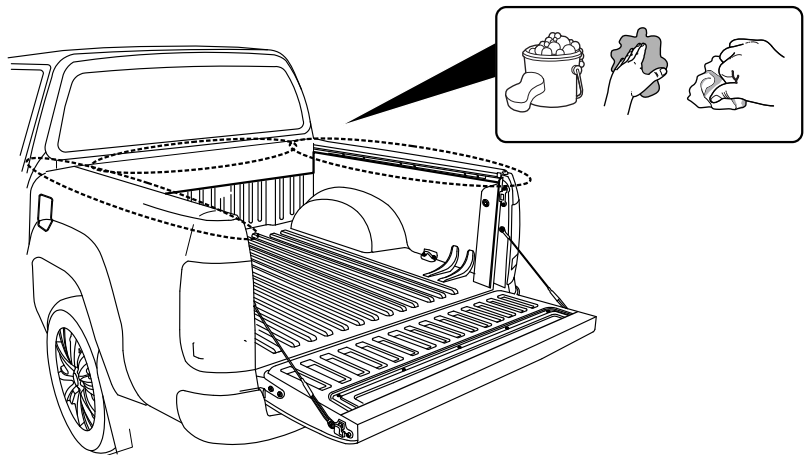

The following steps are for vehicles with bed liners. If there are no bed liners installed move to next page.

Trim front of bed liner by 110mm from the top of the ute's headboard as shown.

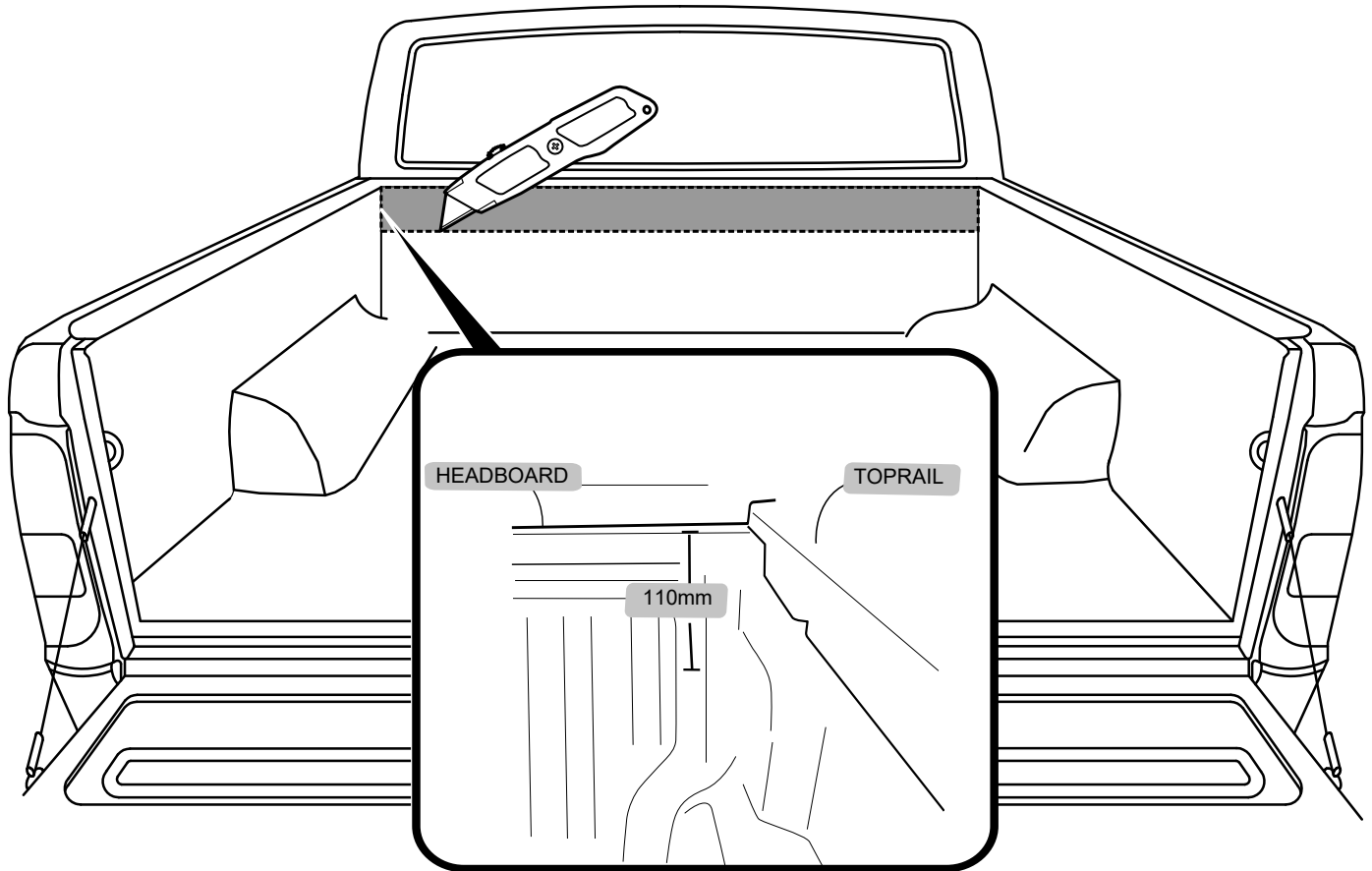

Measure 5mm down from top edge of tailgate and trim tailgate liner.

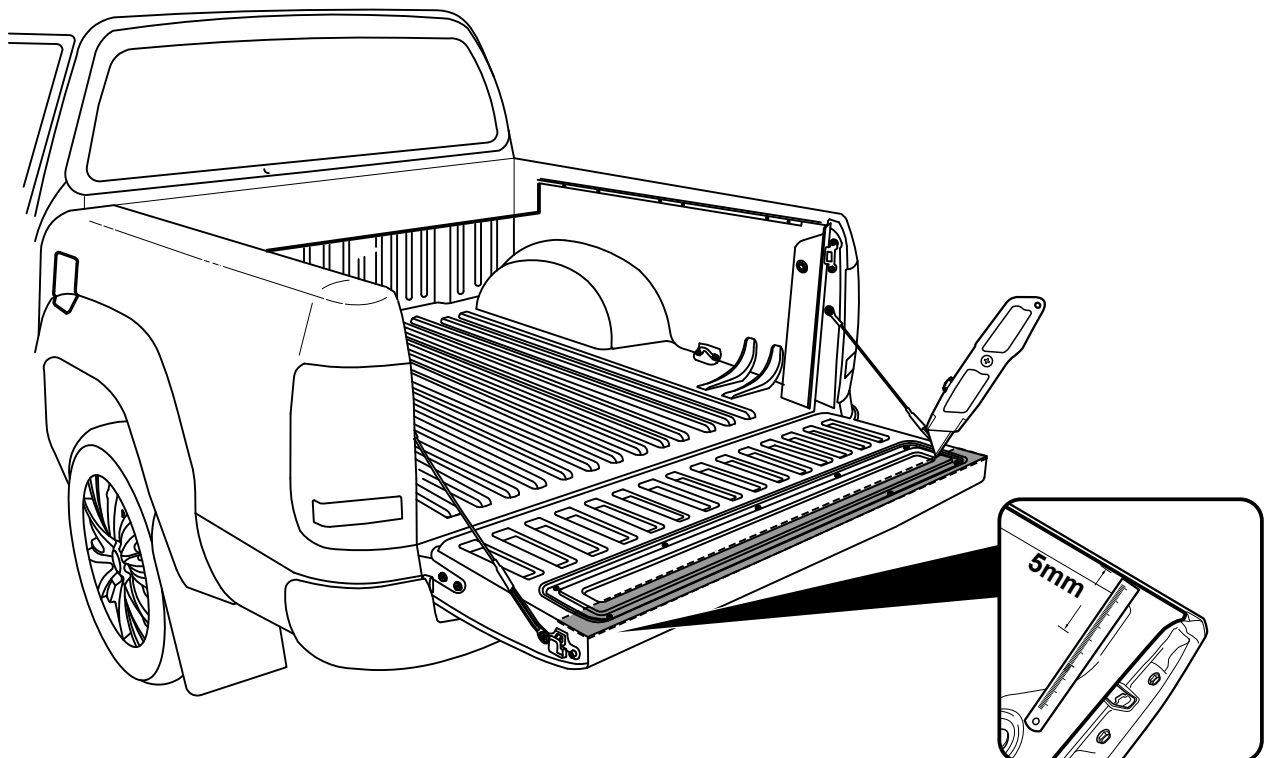

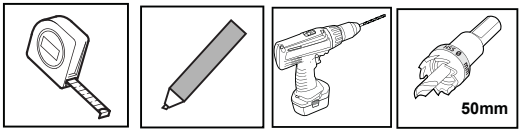

Measure down from top of headboard 180mm & 105mm measuring from the side of the top rail.
 Repeat to the other side.
 Using a 50mm hole-saw drill the liner only as indicated.
 NOTE: Only drill the tub liner at this step.

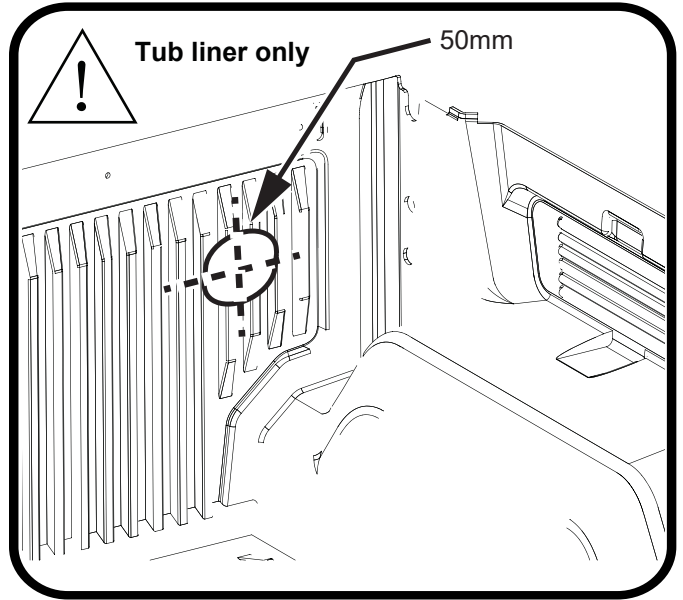
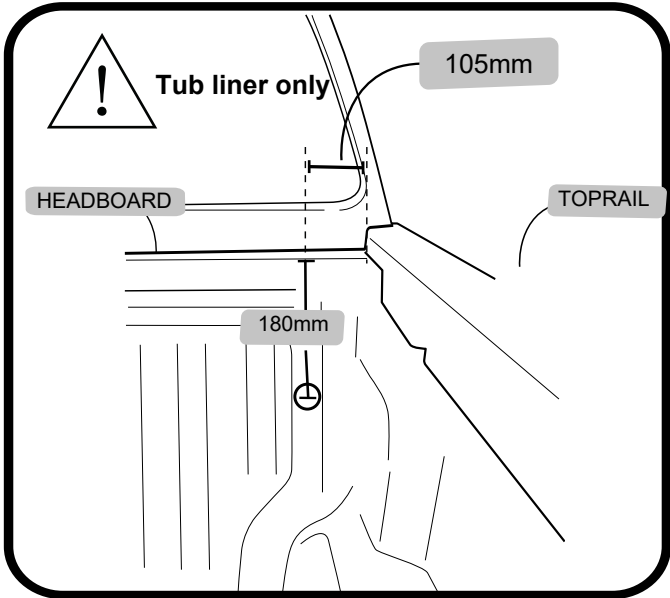

Now measure down from top of headboard 180mm & 105mm measuring from the side of the top rail. Repeat to the other side.
 Now using a 30mm hole-saw drill through tub front panel, file away any sharp edges. Apply anti rust coating. Repeat to other side.

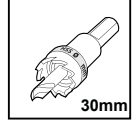
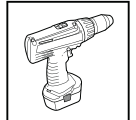
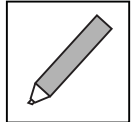
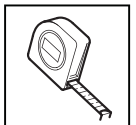
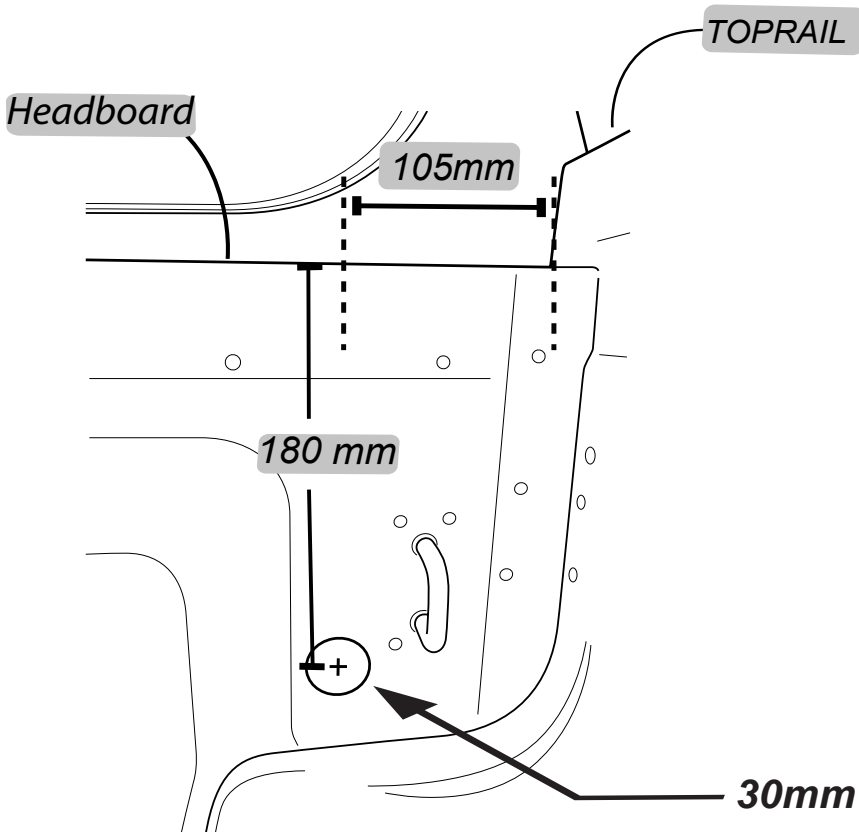

! ATTENTION: Do not exceed 30mm hole.

Carefully unpack the box.

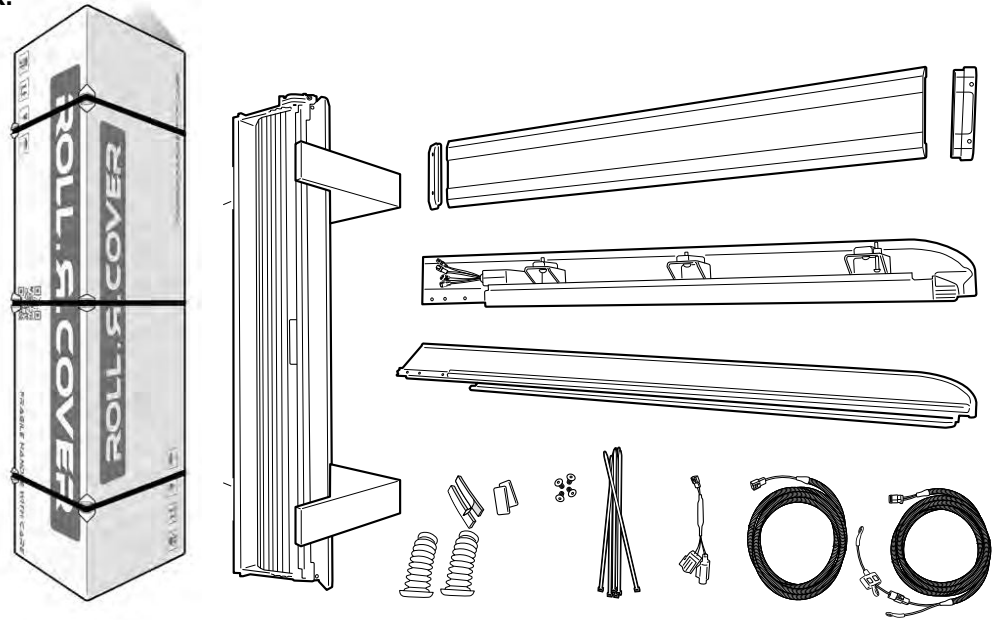

Place front bar assembly (FBA-Q4R) over the head board.

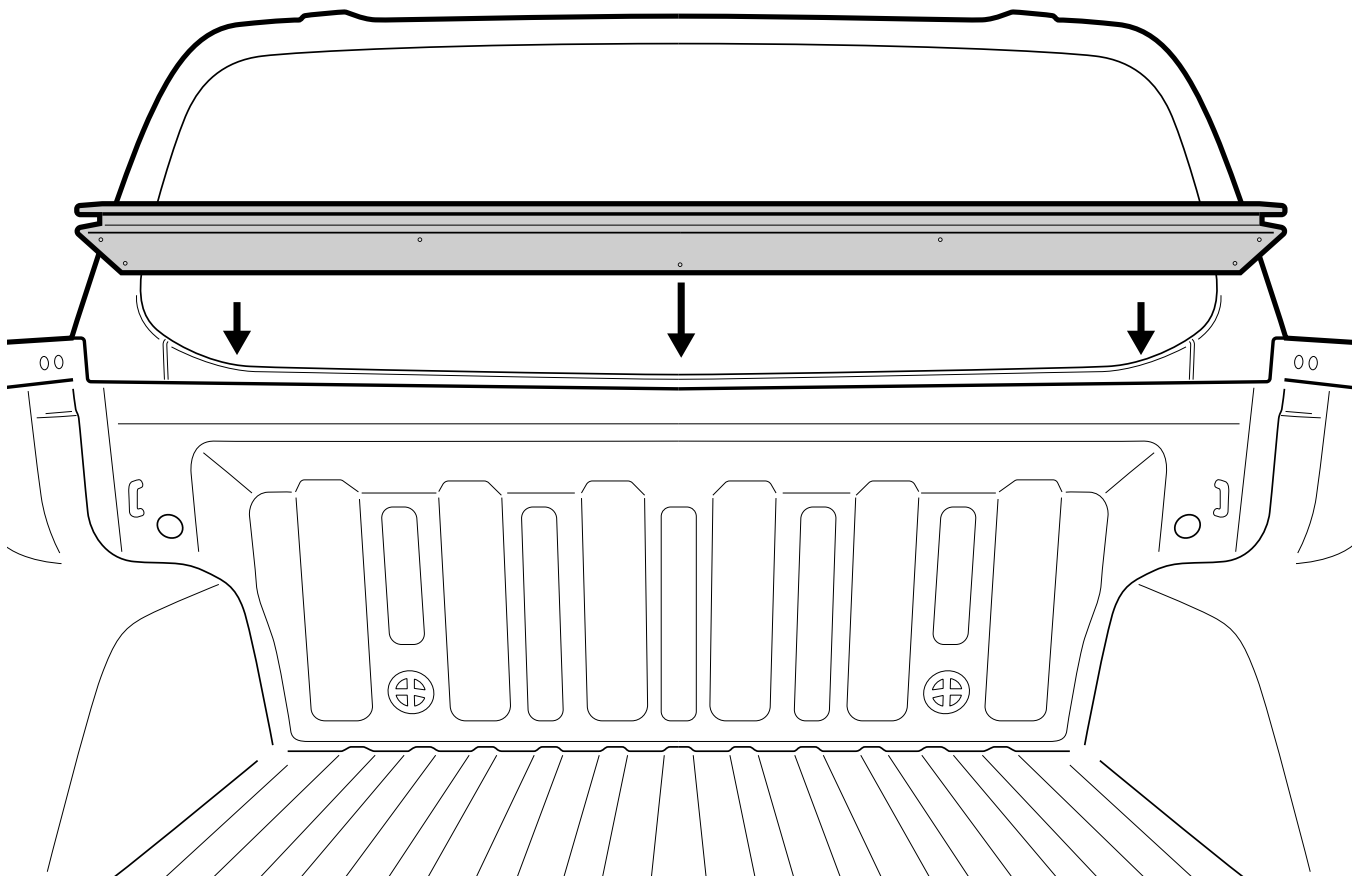

Center the front bar assembly.

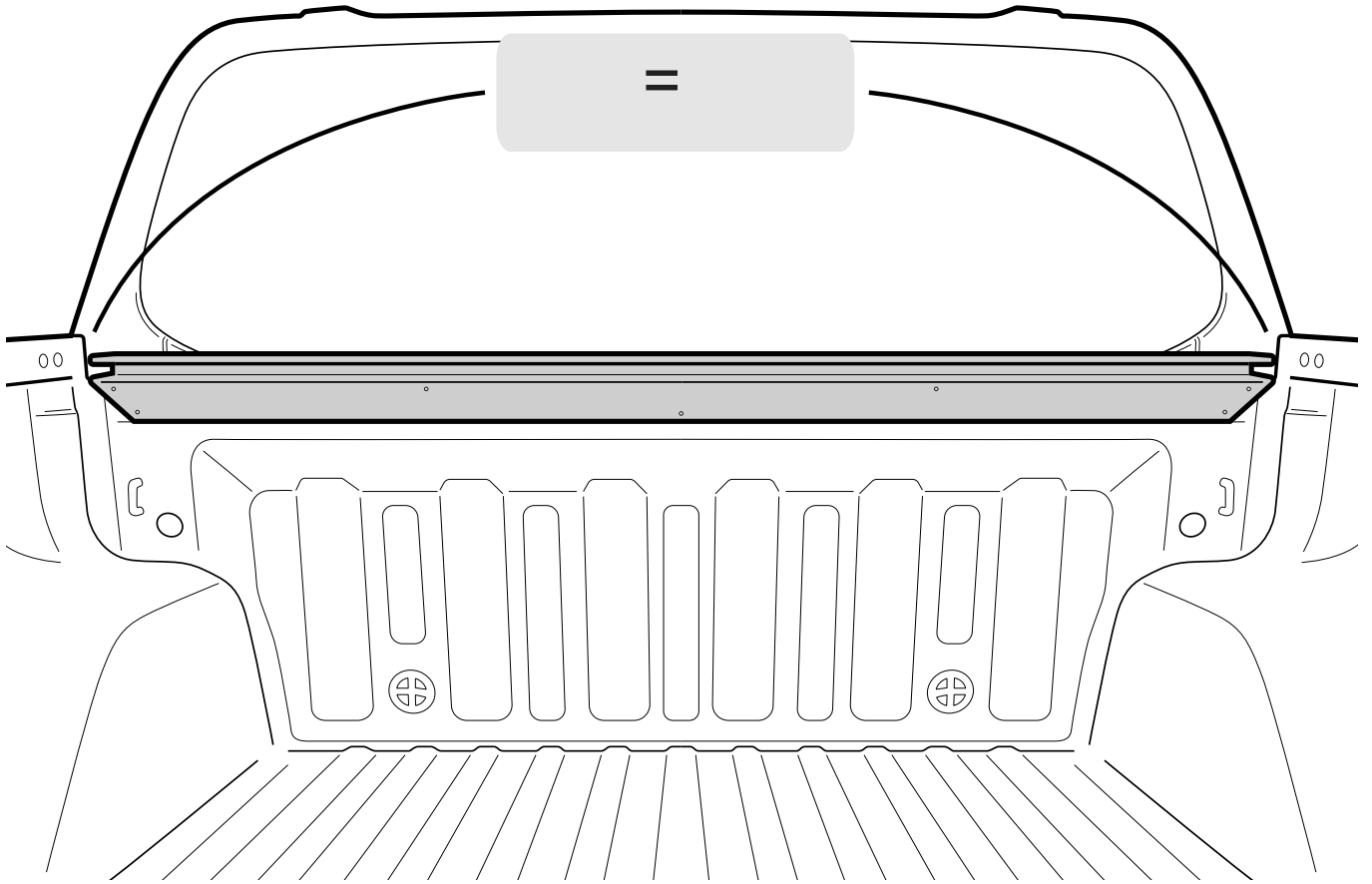

 Apply pressure down to FBA bar then fasten into position using supplied self drilling screw to indicated areas.

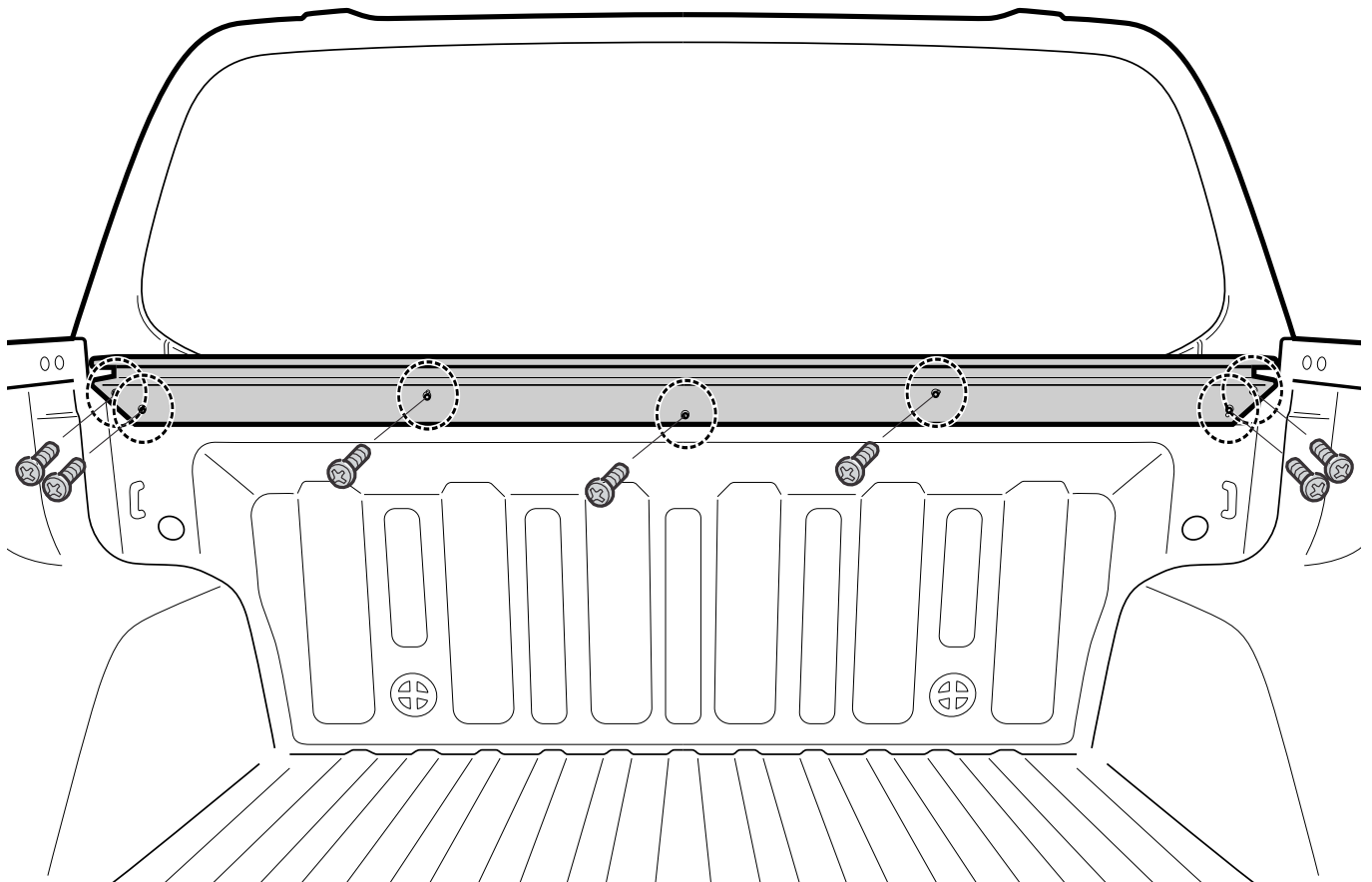

Sealing any gaps on the bed and FBA. It is recommended to use black sealant.

Apply an adequate amount of sealant to the areas indicated, then smooth sealant out.

Clean any excess sealant. Repeat to the other side.

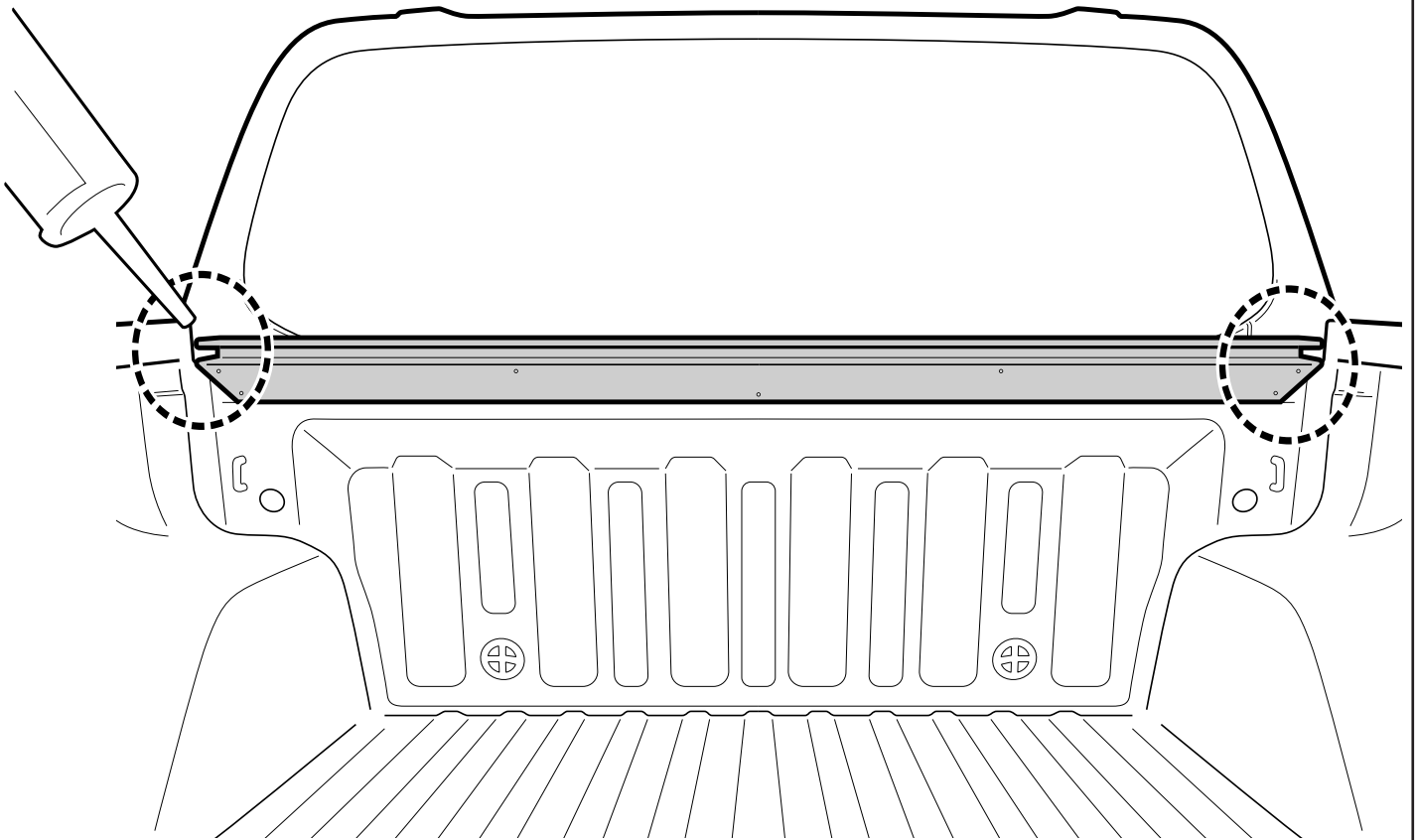

Install front drain pipes (55mm diameter end of hose) through pre-drilled holes on the front tub panel.

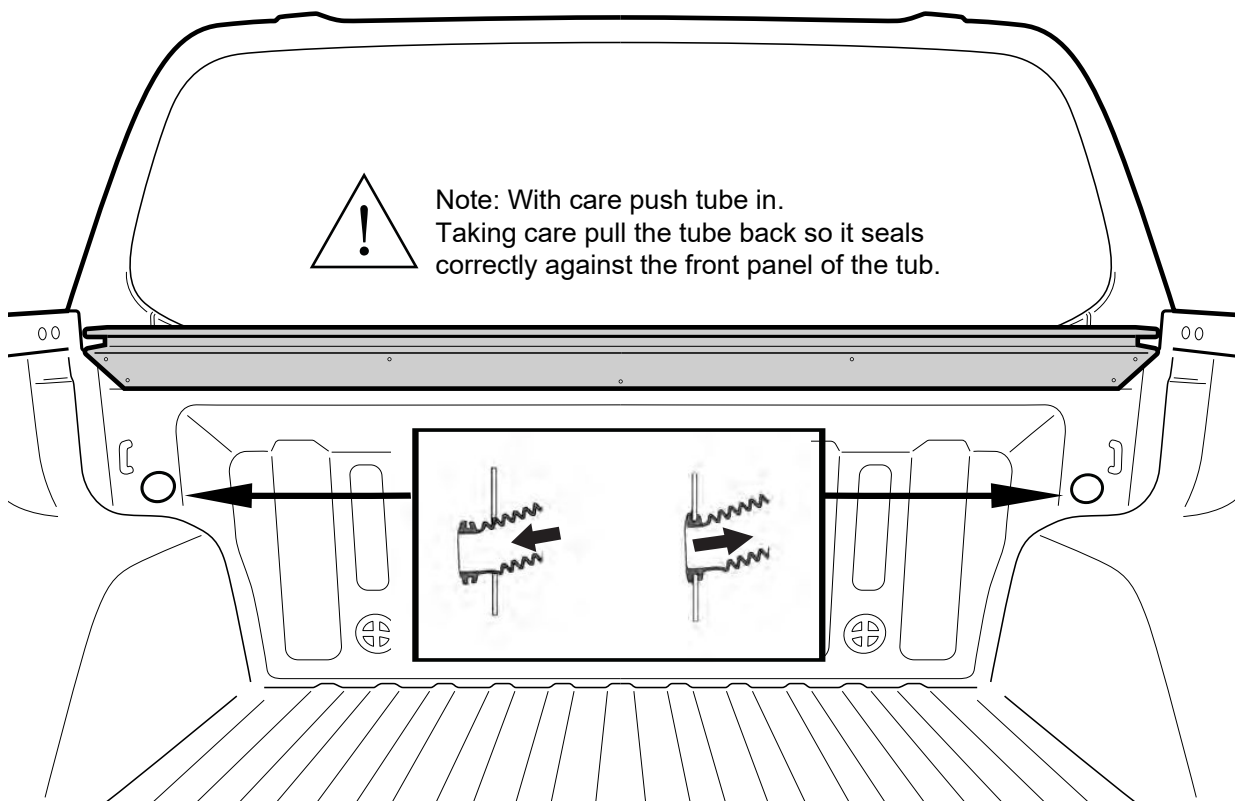

Disconnect fuse patch from battery loom S2.75.

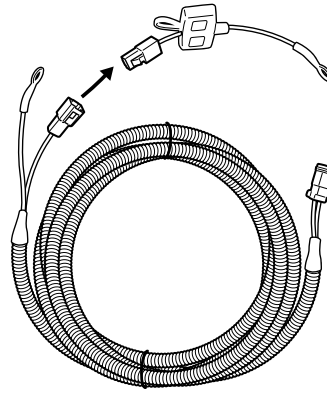

Wiring Harness steps

1 Feed Battery Loom S2.75 through the cavity

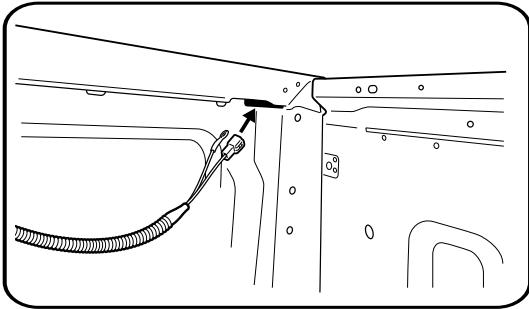

3

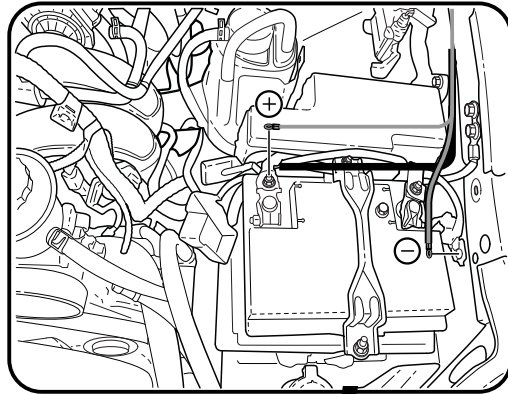

2

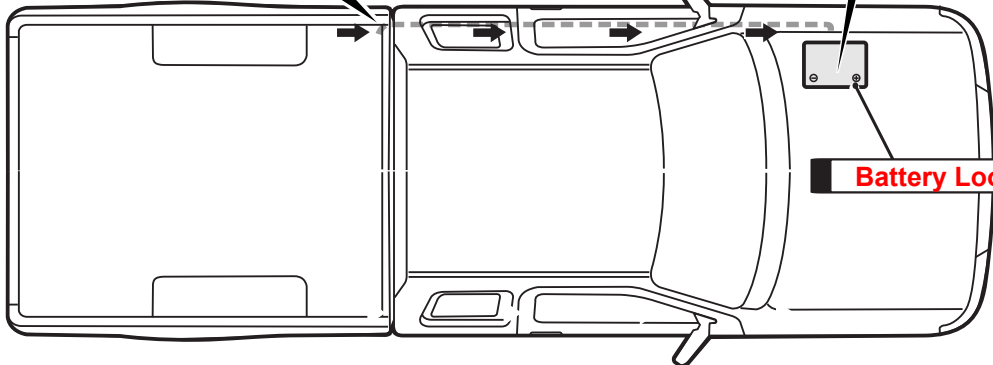

Run the wiring from the front corner cavity (leaving 200mm in the tub) to the battery over the chassis rail. Making sure to keep away from hot obstructions and cable tie every 400mm. Reconnect fuse patch to battery loom S2.75, now attach fuse patch to positive of battery and earth to the body of the Ute.

Feed CL-Short-Loom through the cavity.

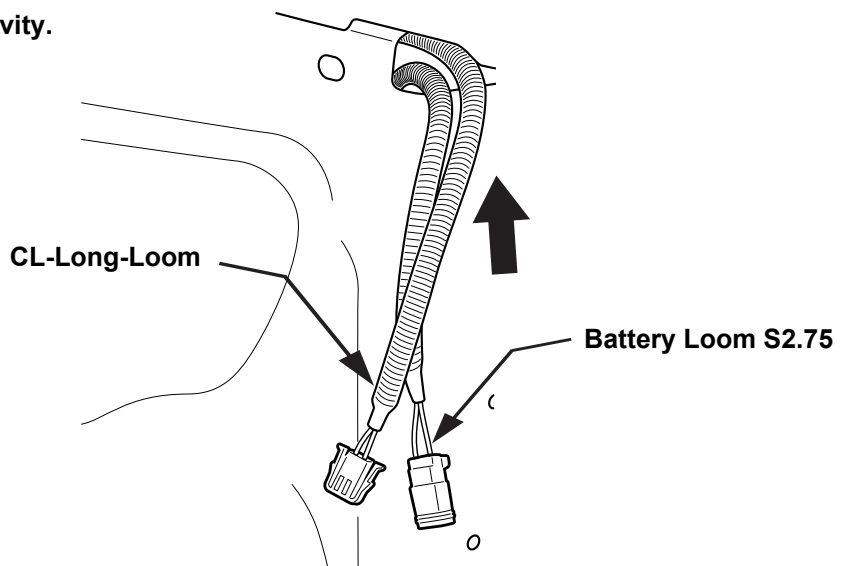

1) Route the CL - Loom-long harness along the LHS chassis rail to the grommet underneath the LHS front seat.

2) Secure the wiring every 400mm with the cable ties provided.

3) Make a slit in the grommet, pass the wiring harness through the grommet (1) and using silicon, reseal the slit.

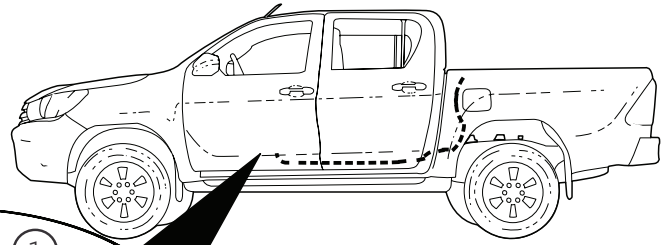
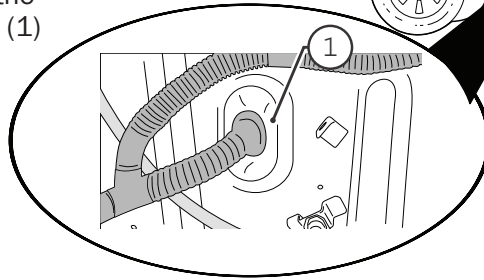

At the front passenger side foot well area:

- Remove front passenger scuff plate (1)
- Remove the kick panel (3)

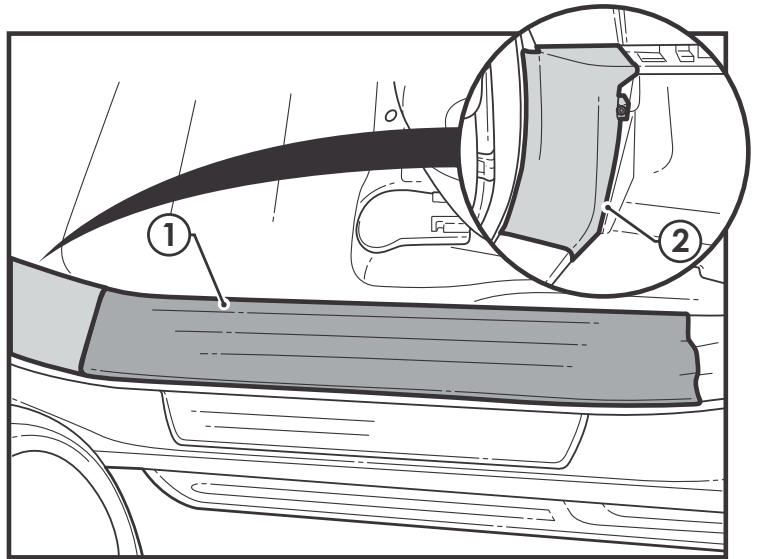

Unplug indicated plug and plug Q-PATCH wiring.

Plug CL-LOOM-LONG to Q-PATCH wiring.

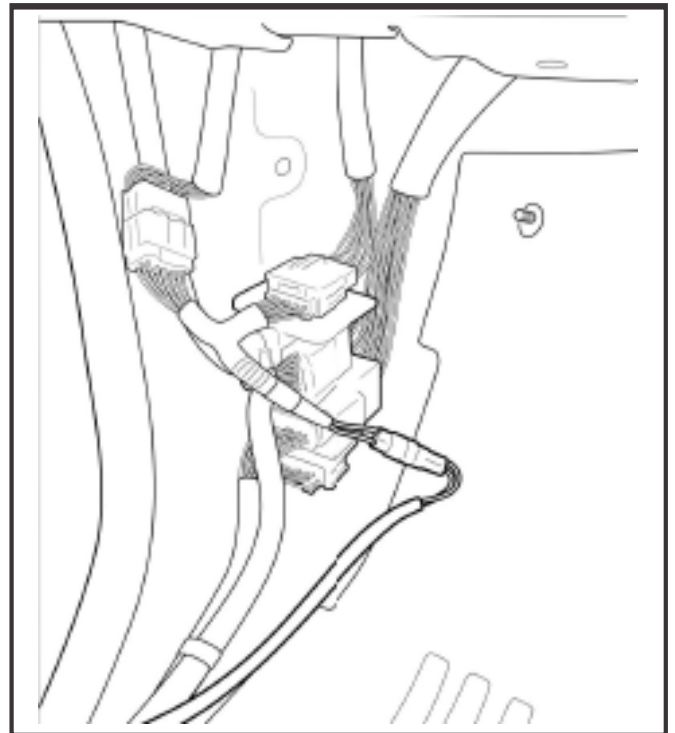
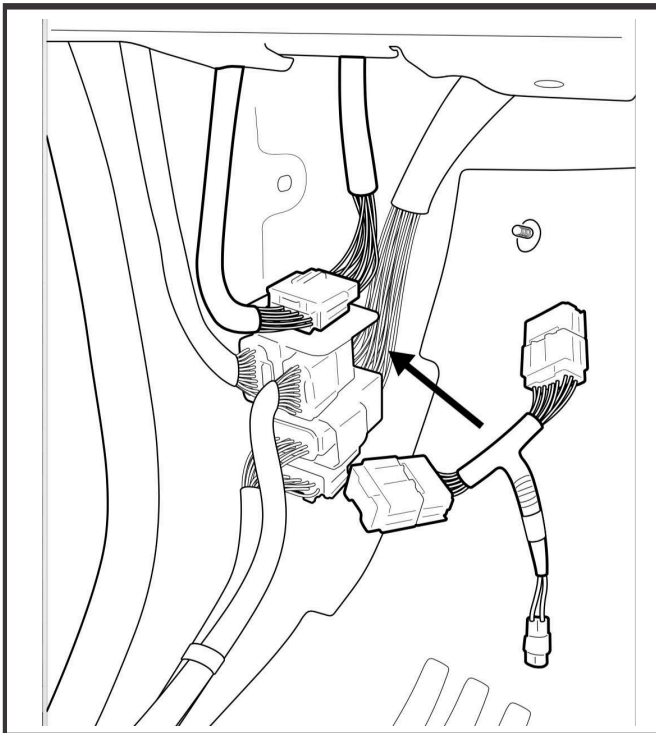

Cable tie overhang of wires and assemble all panels removed earlier.

keep the cannister in the foam blocks from the packaging for assembly.

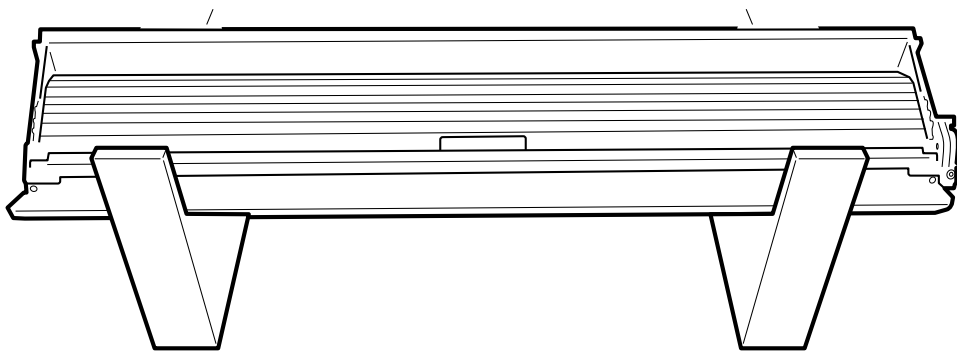

With assistance turn the canister on its back on the foam blocks.

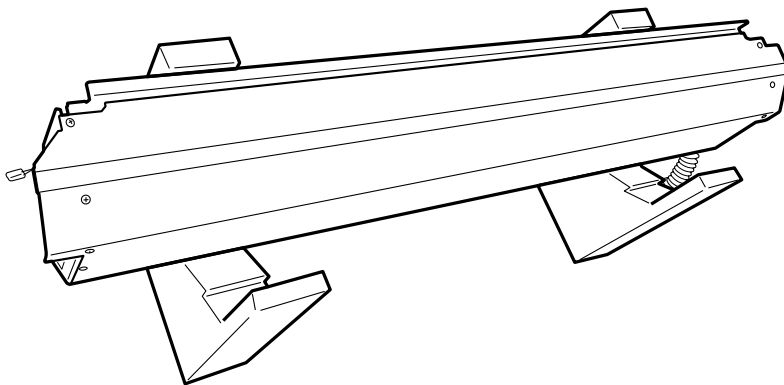

Disengage motor from the axle by unfastening the 3 Screw as indicated. Retain all parts.

Remove and retain the 3 screw from the canister as indicated.

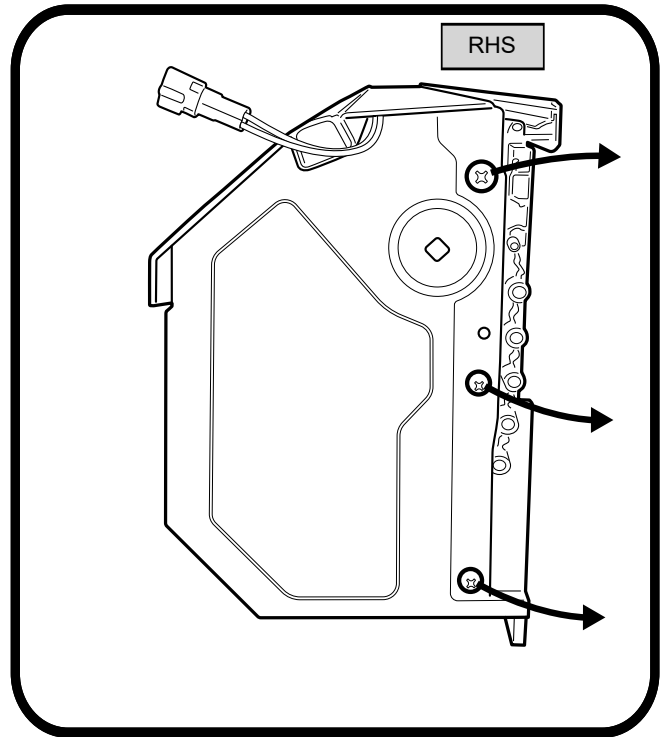
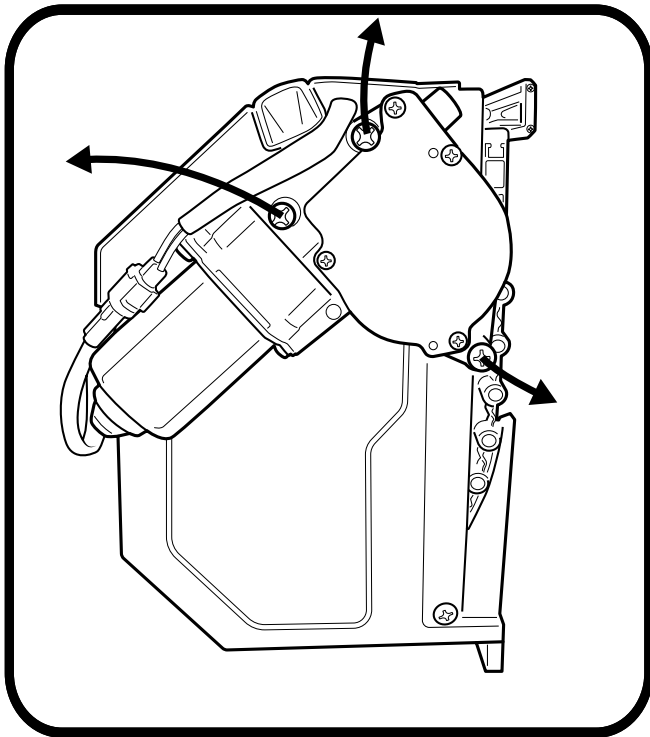
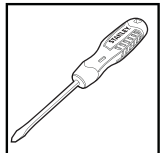

Now on the other side, remove and retain the 4 screws from the canister as indicated.

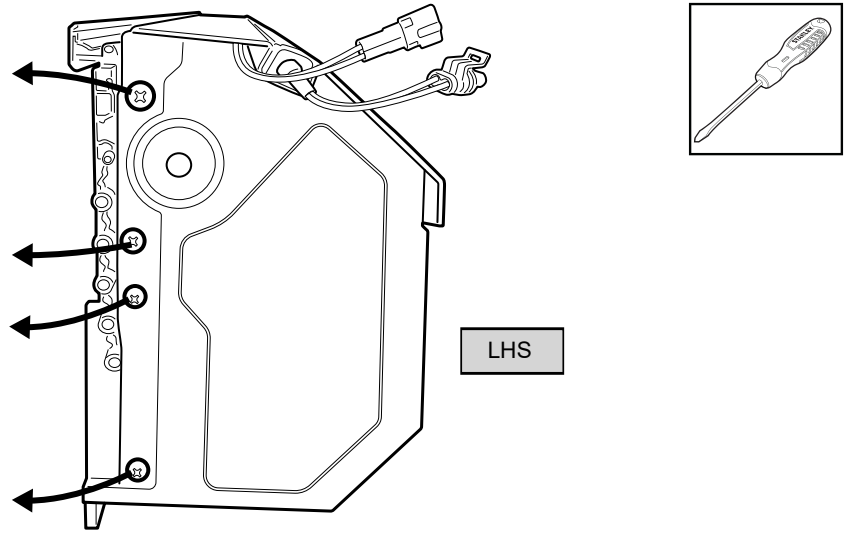

Align side rail to side of canister, guide the track to go in between the curtain end robber stop.

NOTE: LHS side rail to be assembled first.

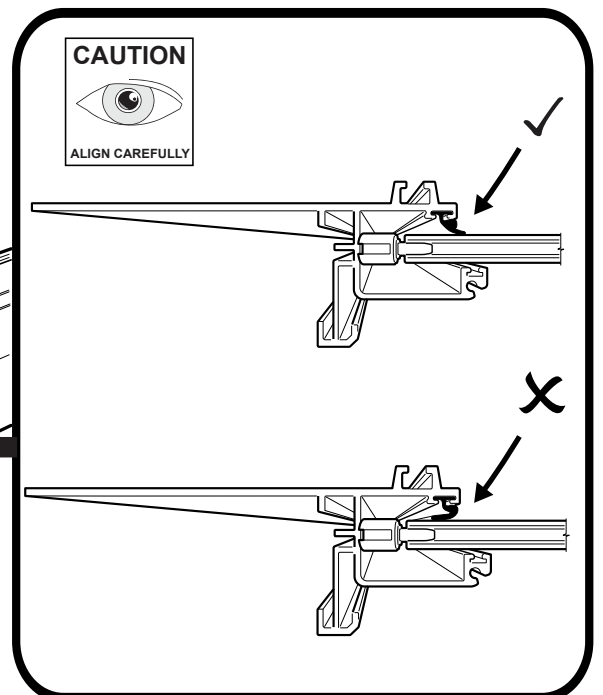
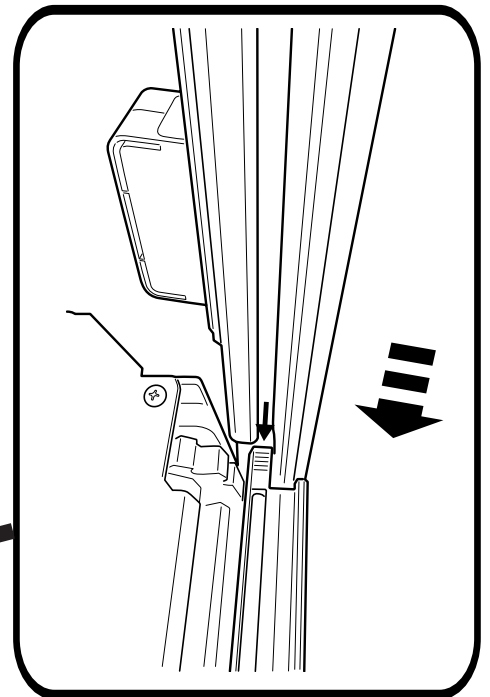
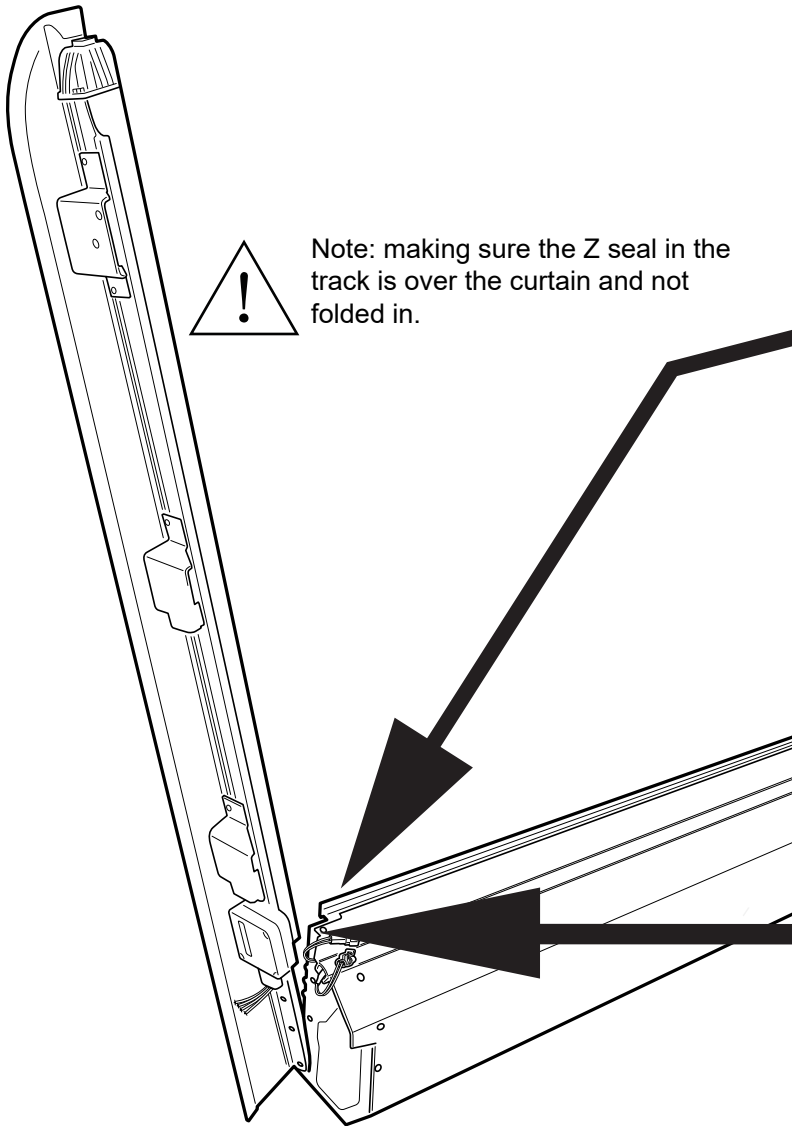

1. Using the retained screws, spring washer and washer, Loosely fasten the side rail to the location indicated.
2. Side rail edge must compress and meet with the canister profile as indicated below.
3. Fasten all screws tight.

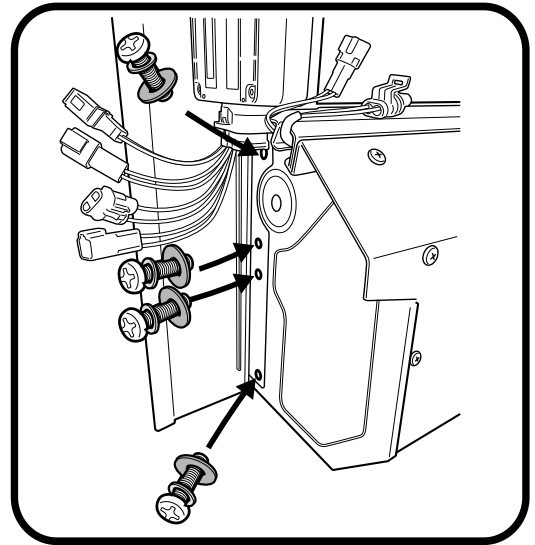
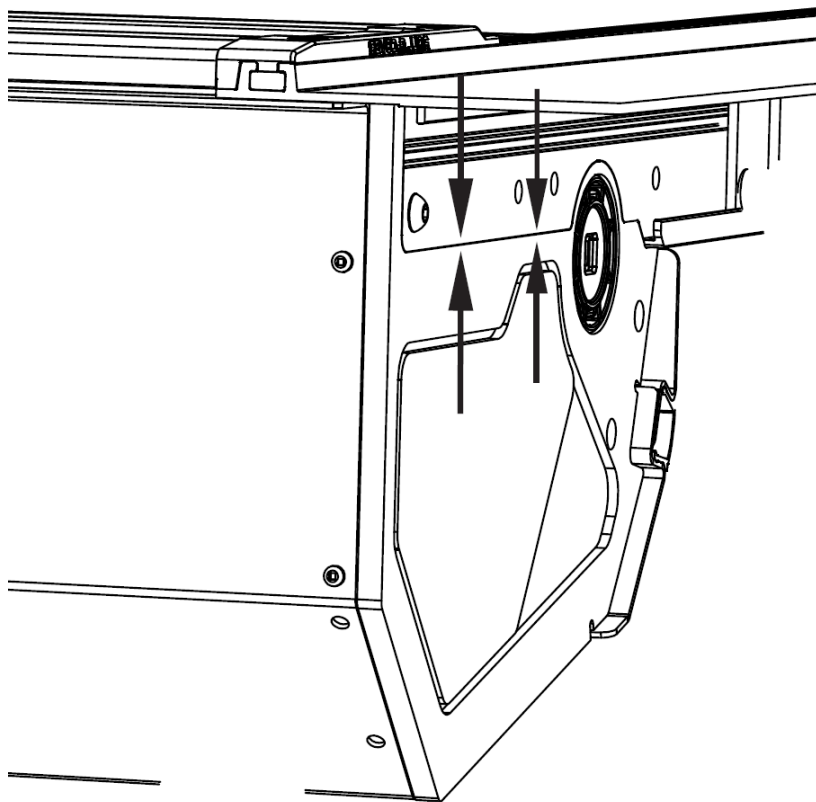
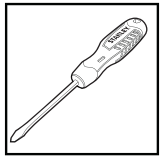

Connect motor connector to receiver

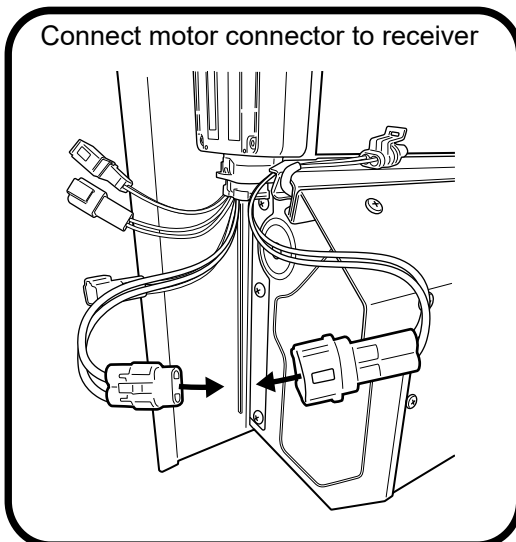

Connect LED Loom to receiver

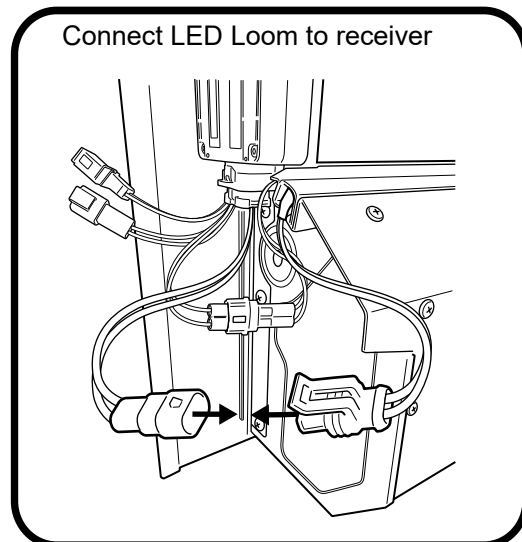

Align side rail to side of canister, guide the track to go in between the curtain end robber stop.

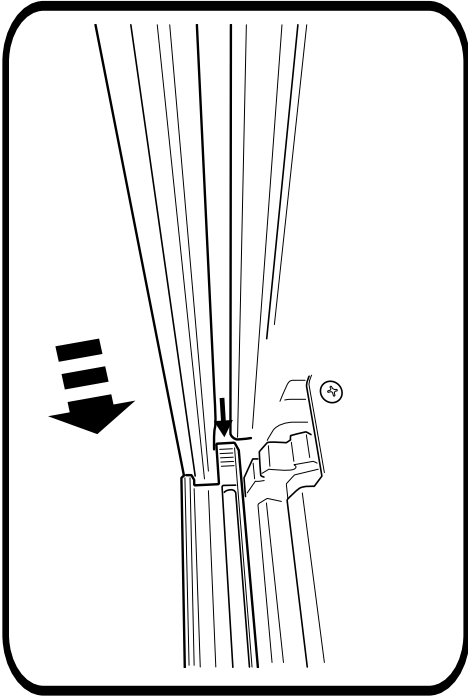

Note: making sure the Z seal in the track is over the curtain and not folded in.

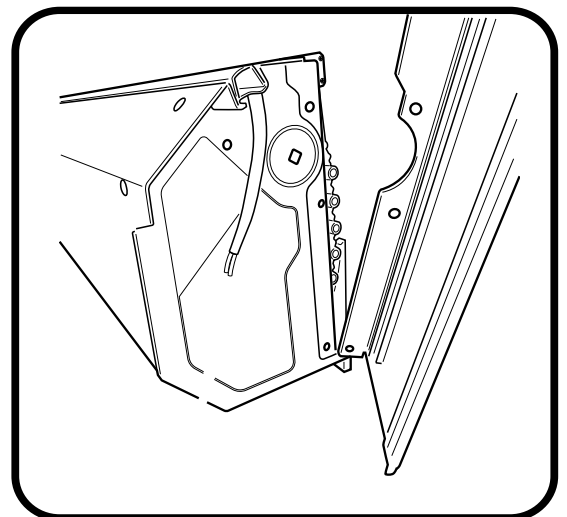
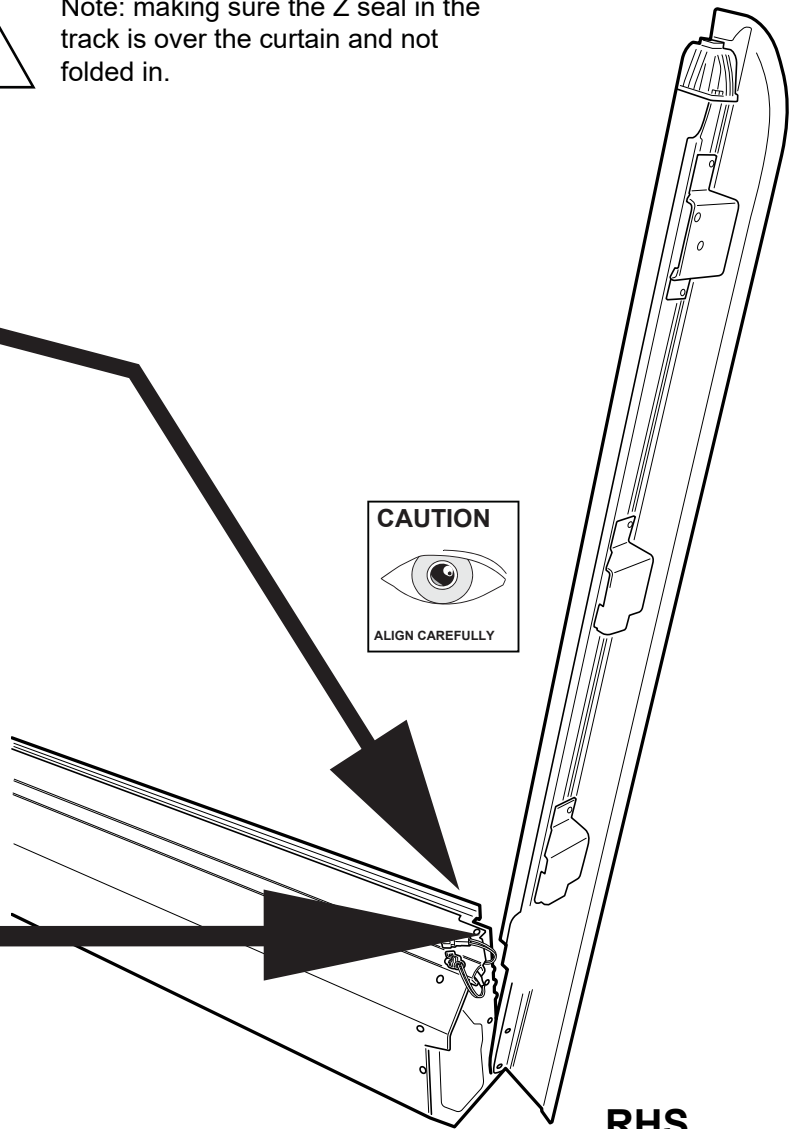
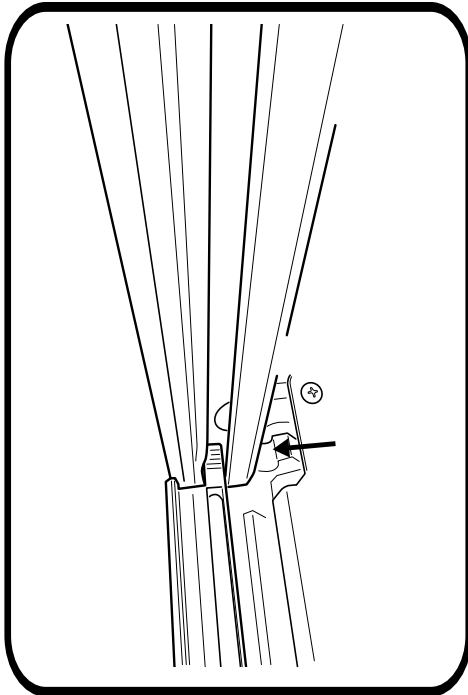

1. Using the retained screws, spring washer and washer, Loosely fasten the side rail to the location indicated.
2. Side rail edge must compress and meet with the canister profile as indicated below.
3. Fasten all screws tight.

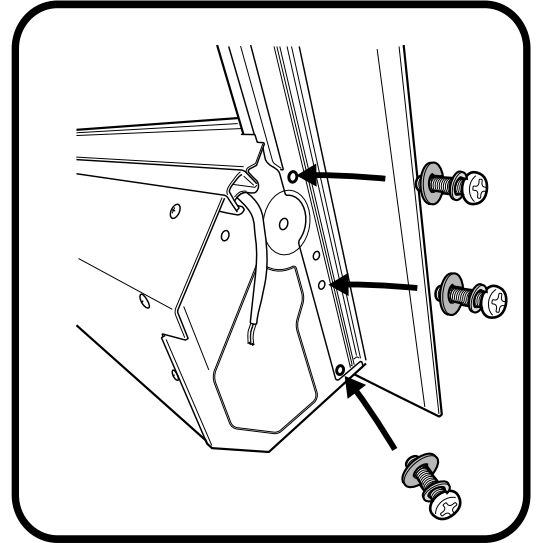
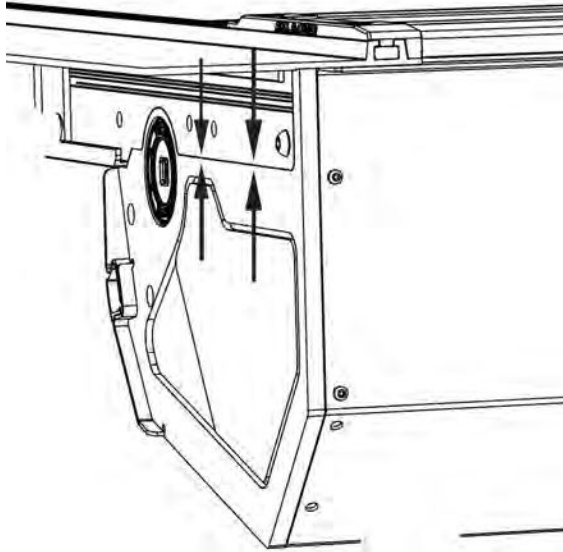
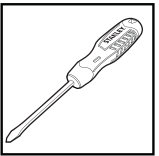

Feed M6 bolt through spring washer, motor and rubber bush.

NOTE: Rubber bush orientation has to be as per image. (side with text on rubber, to face the motor).

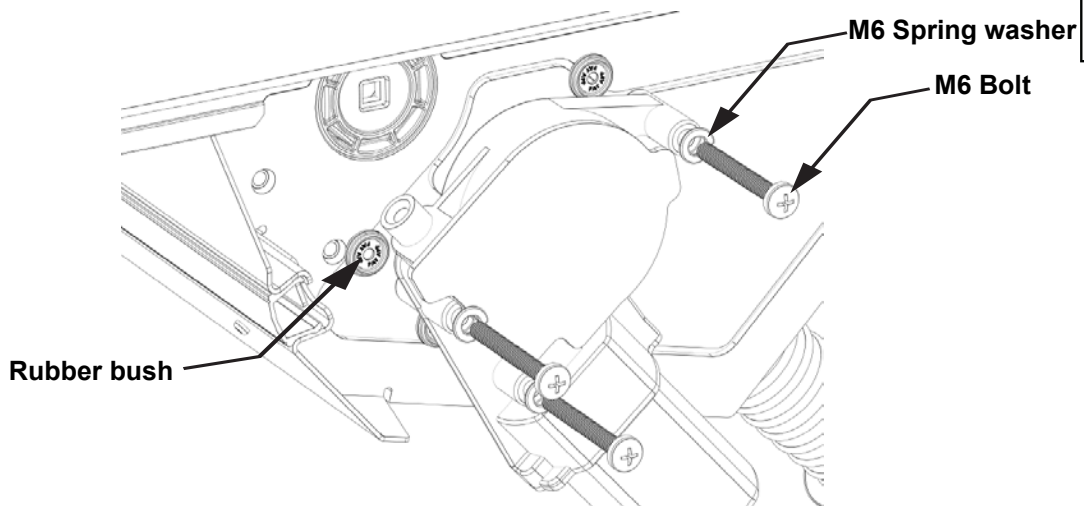
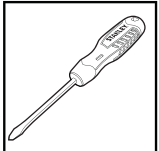

Align & insert motor shaft to axle.

NOTE: Pull / push curtain for axle to rotate.

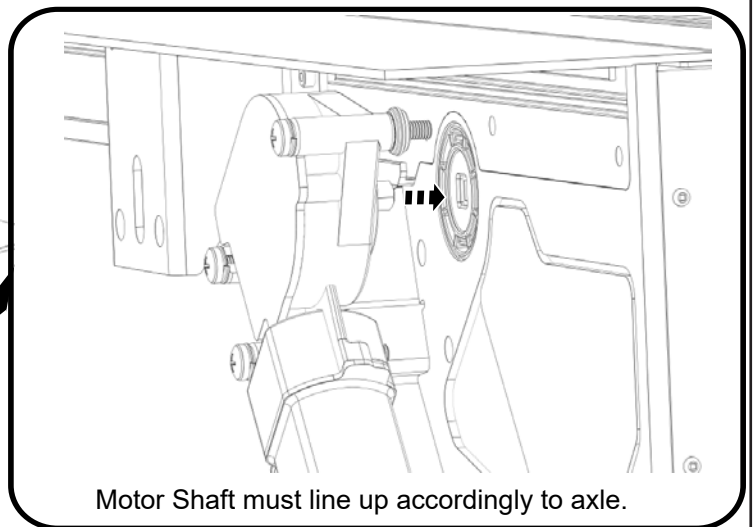
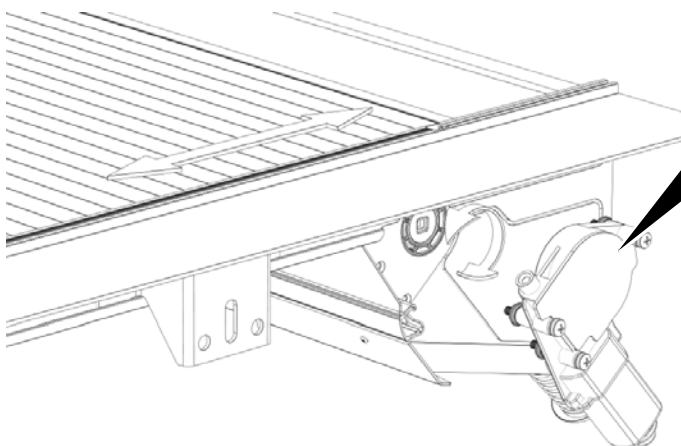

Fasten all 3 screws to 2nm torque. Over tensioning will cause operating issue's.

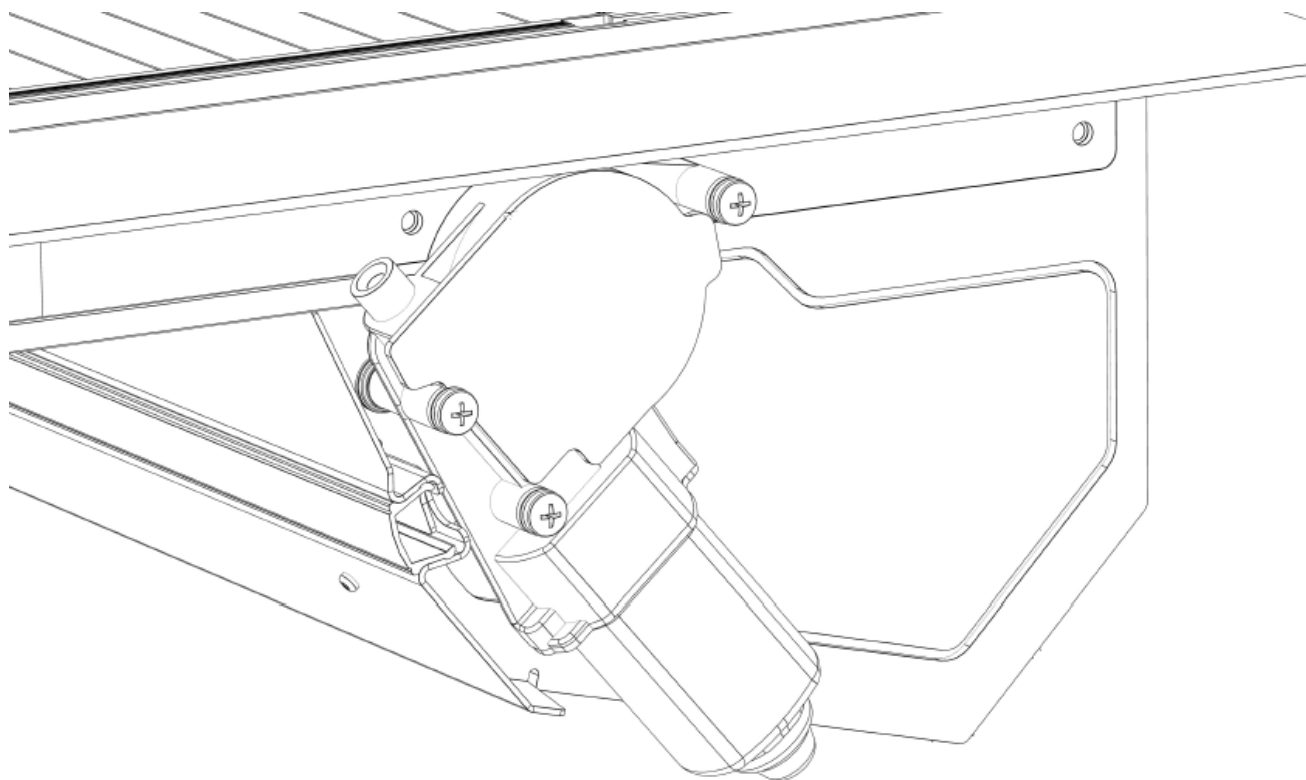
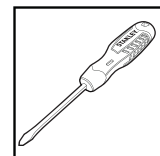

Motor is to sit level.

Any obstructions between motor and canister may cause operating issues.

Carefully bring down the assembled unit.

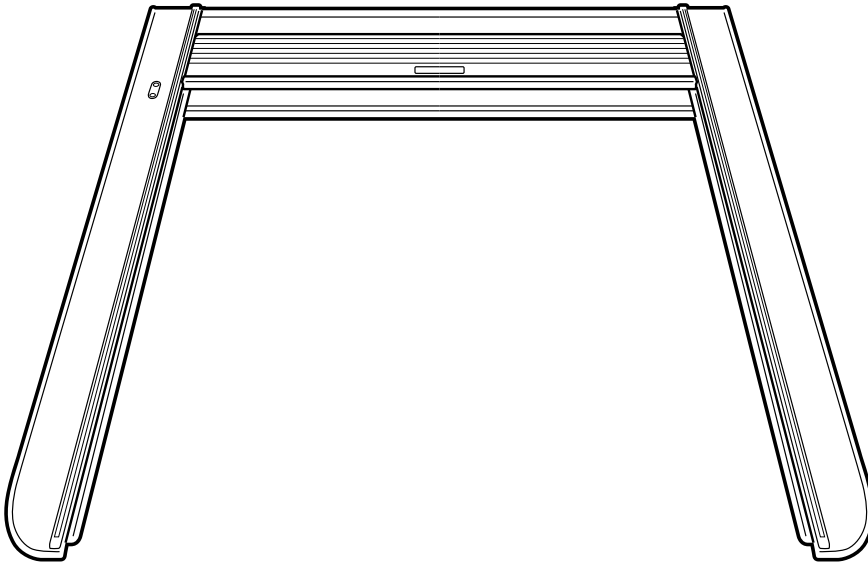

Insert side end caps to the top cover.

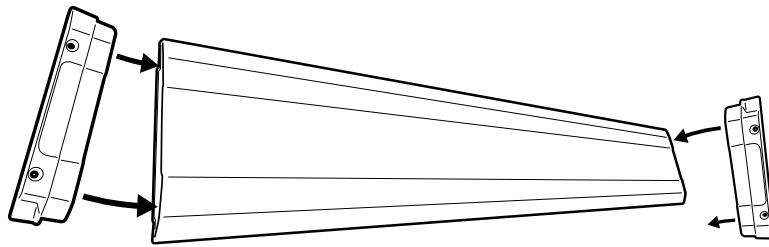

Place & Align top cover over the canister and side rails.

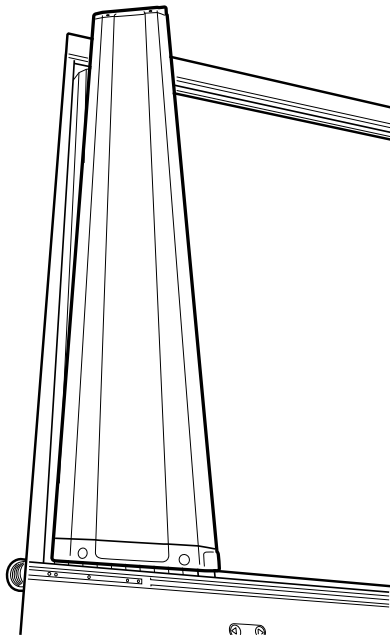

Using countersunk screws provided, line up end cap holes to the threads on the side rail. Fasten to 3nm torque. Repeat to the other side.

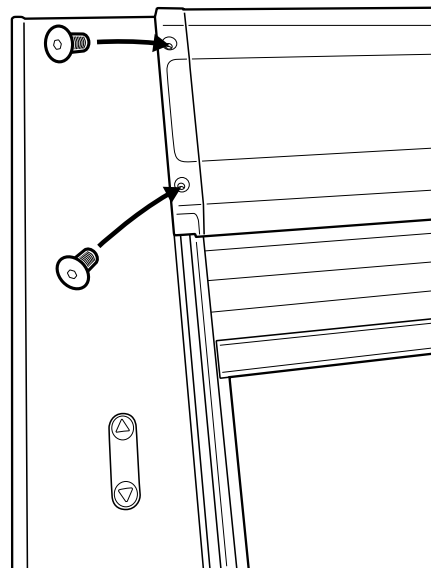

Place the Roll-R-Cover unit on to Ute bed.

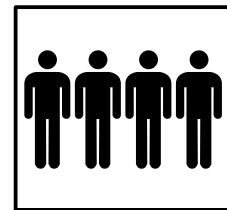
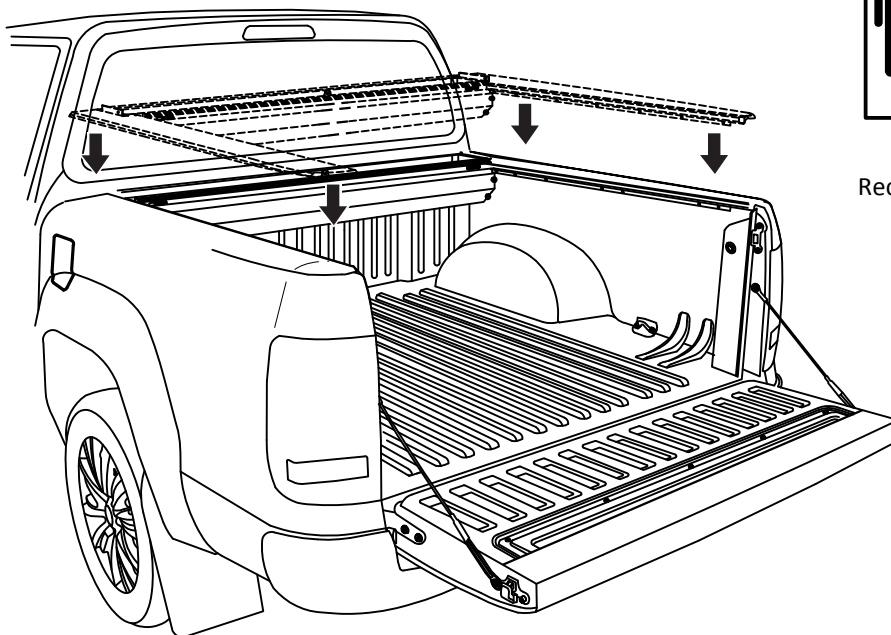

4 People
Recommended for lift

With the tailgate up (Closed position), Pull left & right hand side rails towards the tailgate, stopping short by 5mm between tailgate and inner bottom lip of side-rail end-cap.

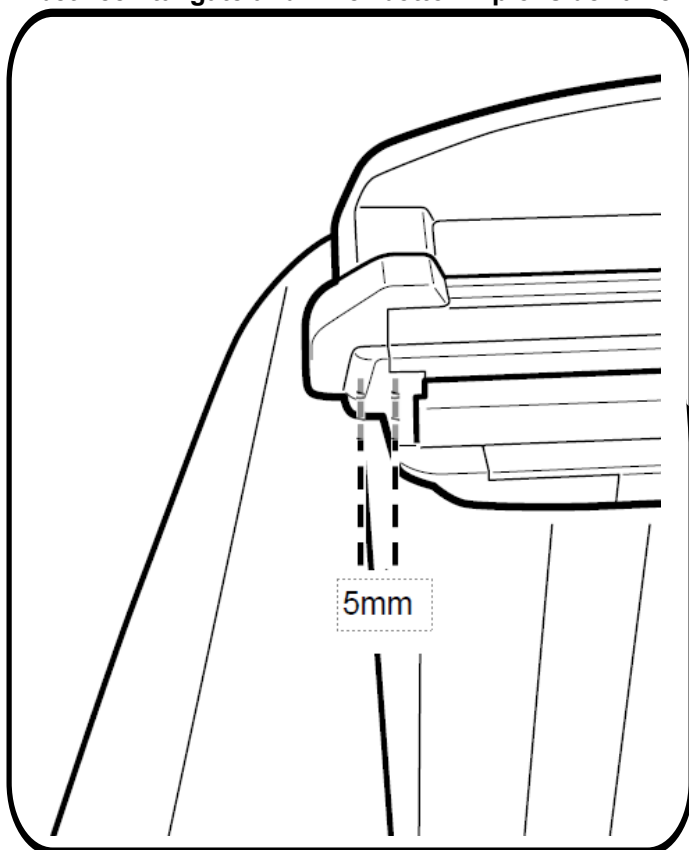

5mm

Tailgate

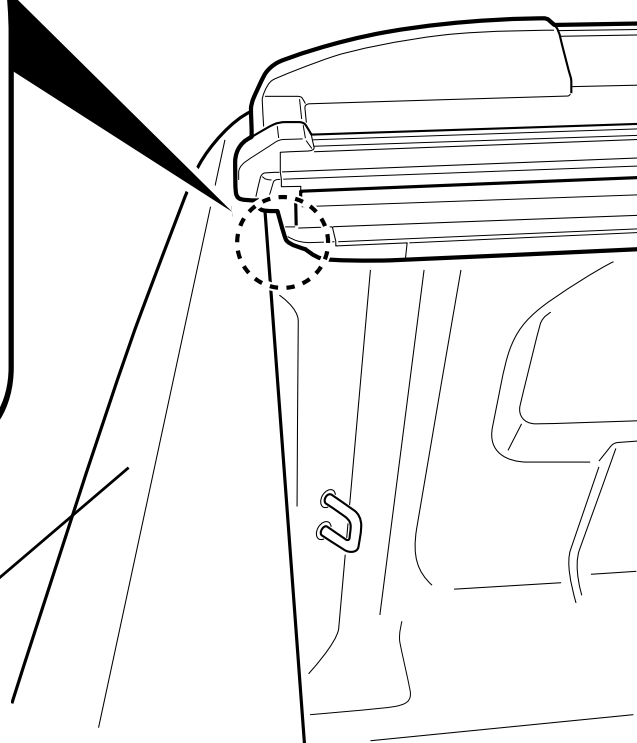

Gap between tailgate and side-rails bottom lip of end cap to be 5mm.

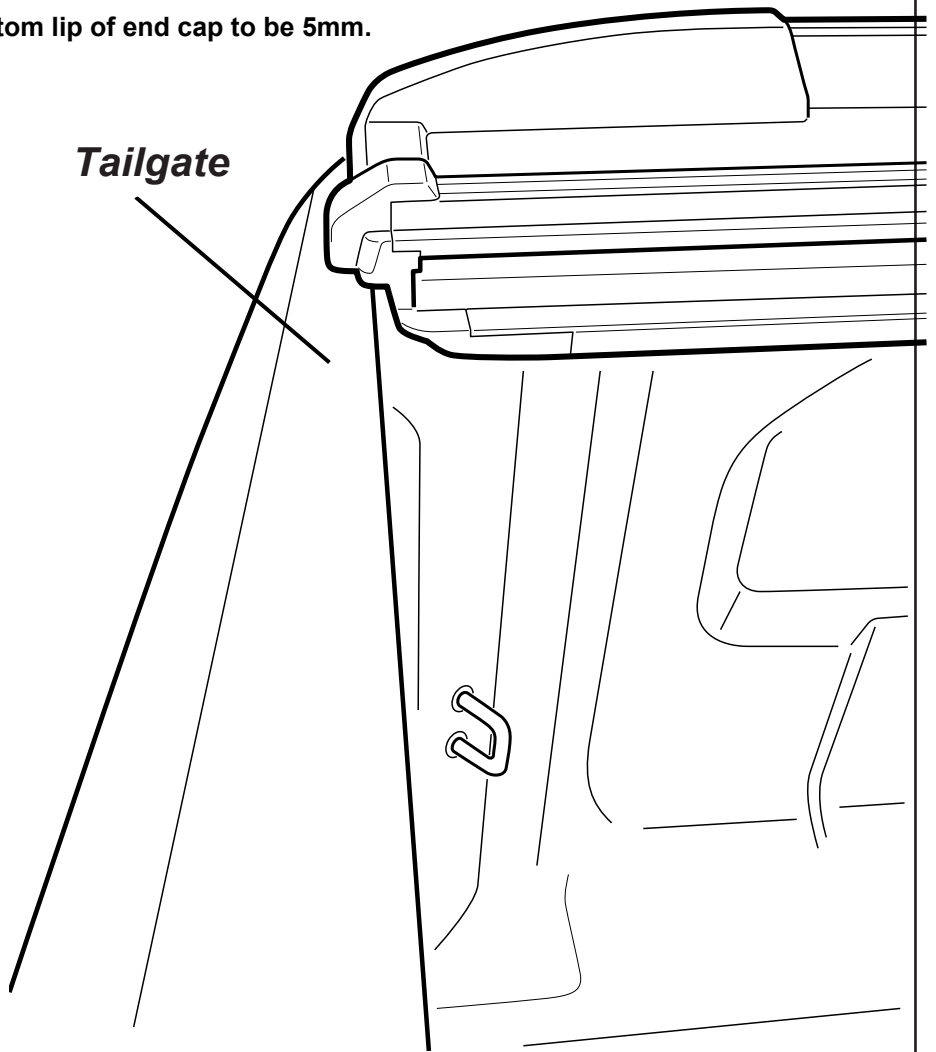

Position clamp behind the inner top lip of the bed rail and the center elongated hole of the side rail mounting brackets. Repeat to all 6 positions. **NOTE:** Clamps to be pushed up all the way and must sit behind the tub inside top rail.

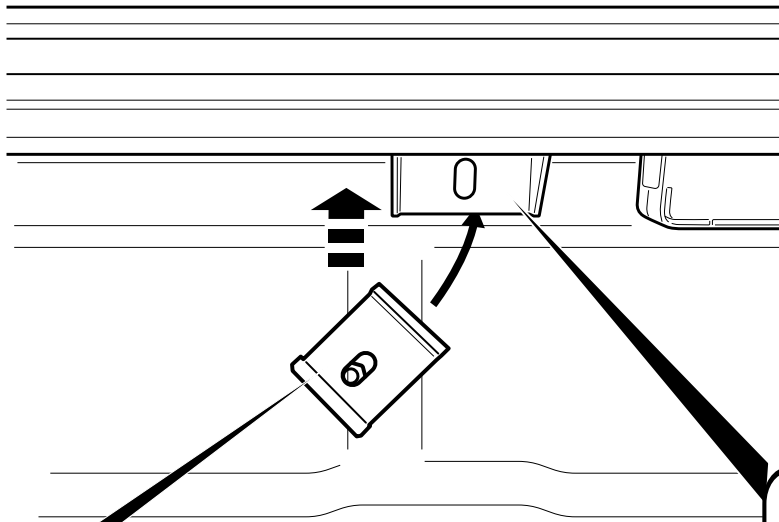

Ensure the M8 nut is in indicated slot of the clamp

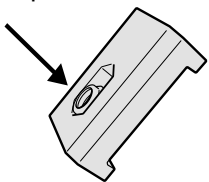

Fasten clamp loosely into position using M8 washer, M8 spring washer and M8 x 35mm bolt.

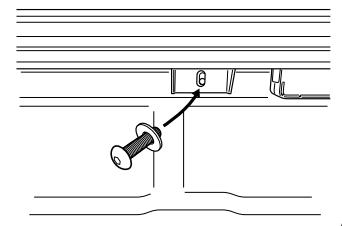

Apply pressure as indicated then fasten clamps to 14Nm torque in the order as per image below.

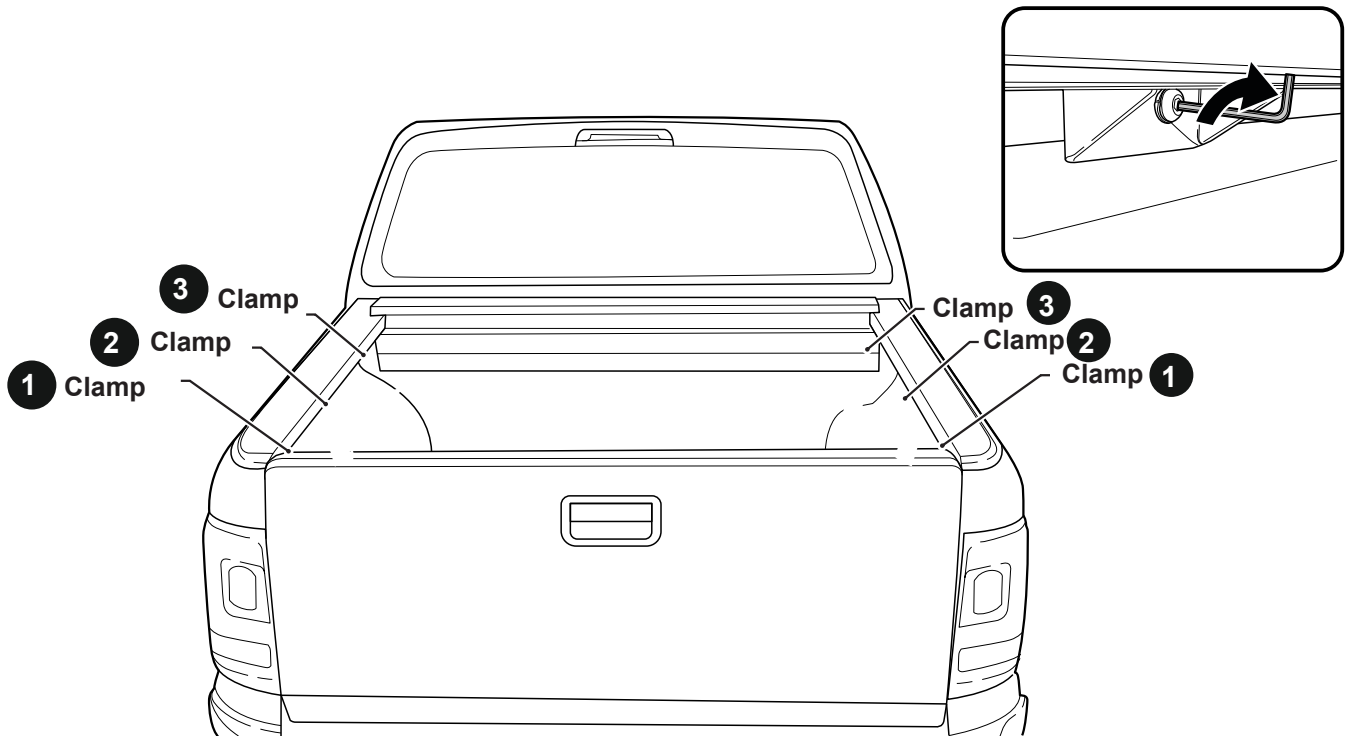
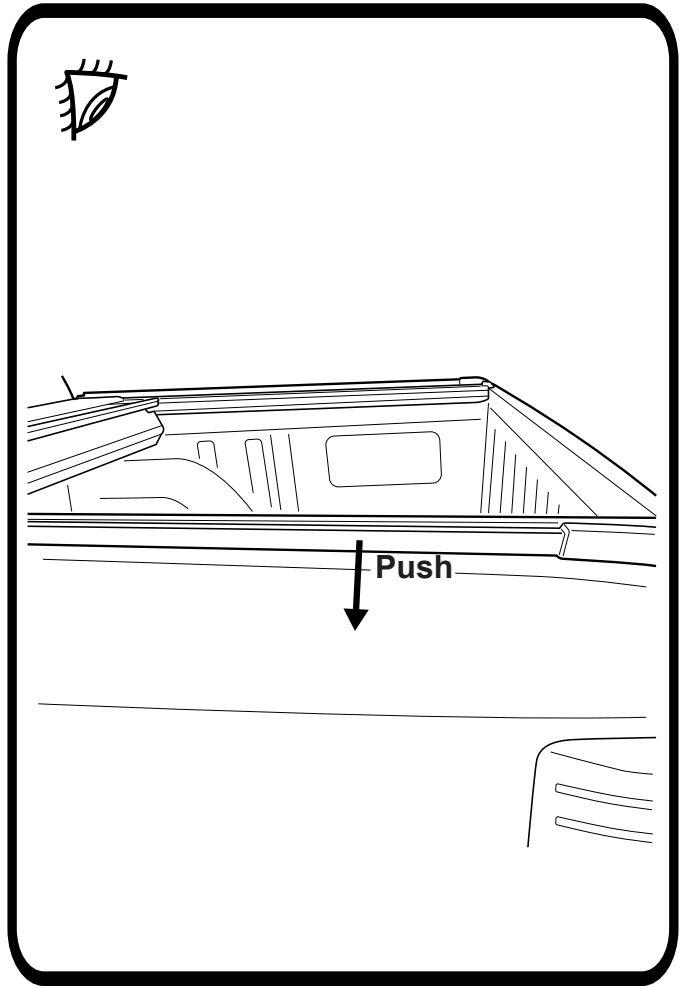
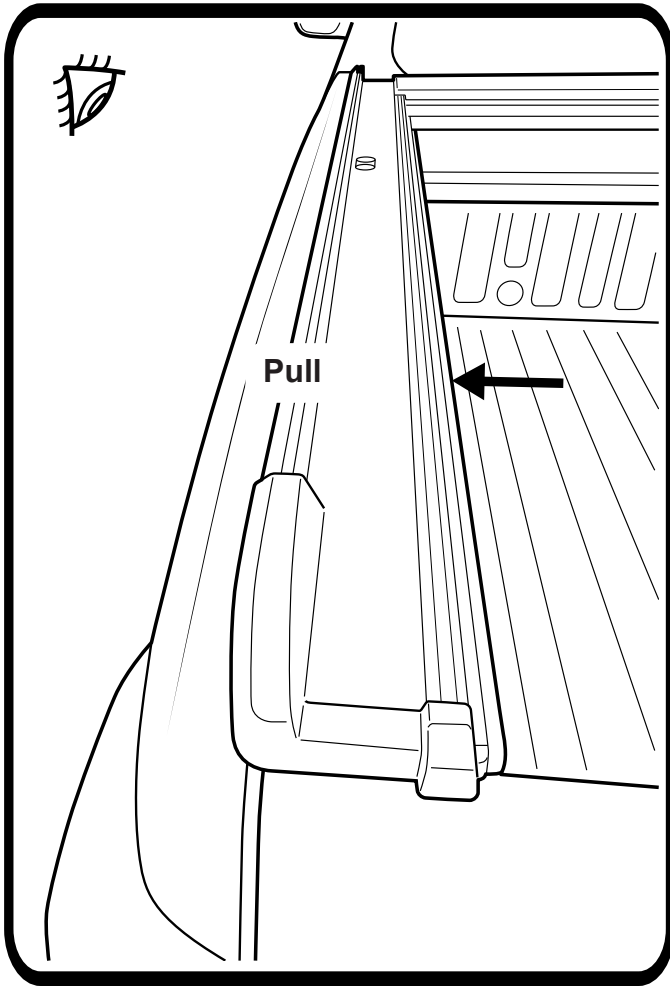

Apply flat plate behind adjusting bolt hole to the ute bed panel or to the liner if the Ute is equipped with a tub liner.

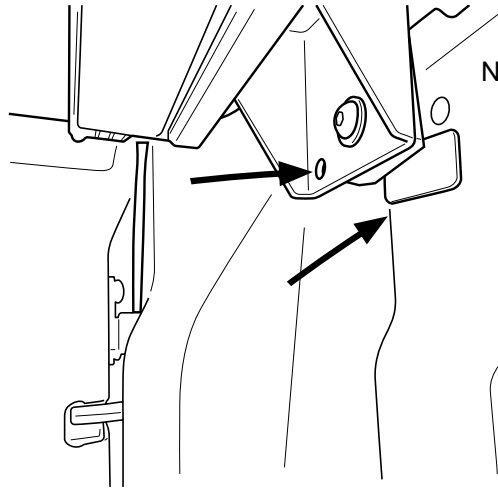

Note: Rear Clamp bracket.



Note: Clean surface before applying flat plate.

Feed M8 nut into M8x90mm bolt and through clamp bracket's pre-installed nutsurt as indicated.

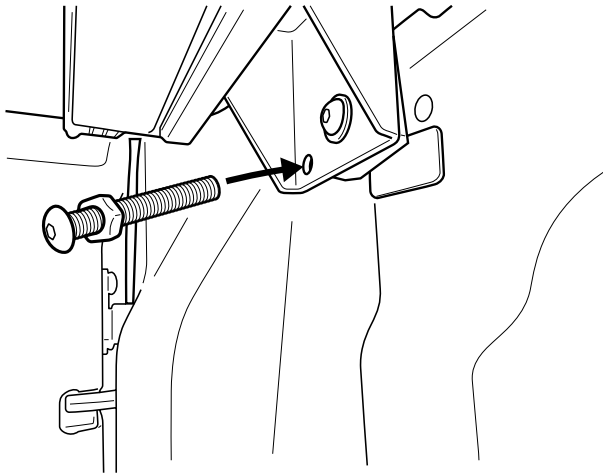

Side rail rubber end cap's inside top edge to sit 2mm above from the top of the tailgate in the closed position.

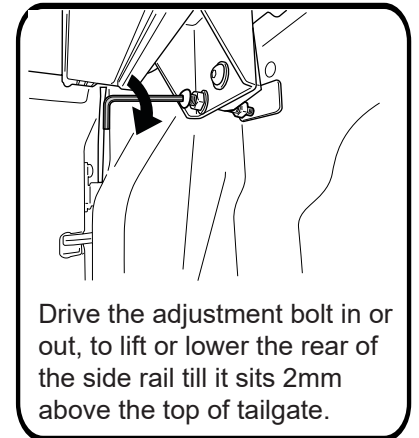
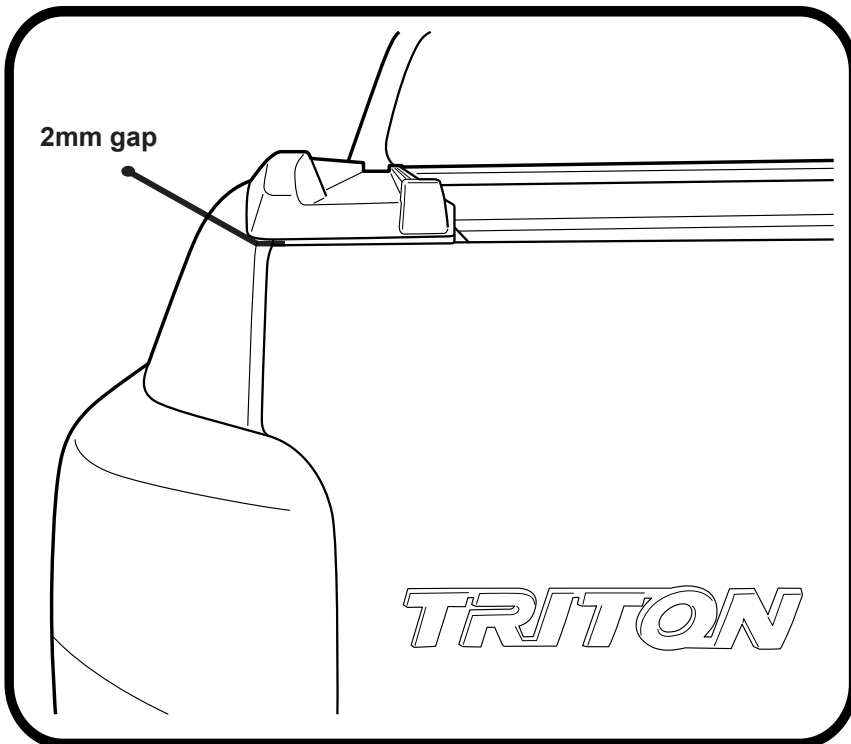

Drive the adjustment bolt in or out, to lift or lower the rear of the side rail till it sits 2mm above the top of tailgate.

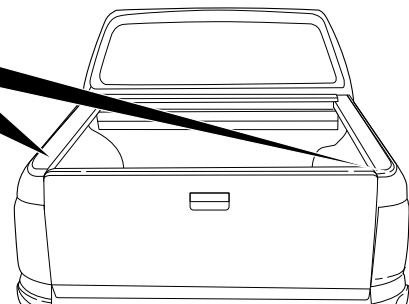

Fasten the M8 nut against clamp bracket.

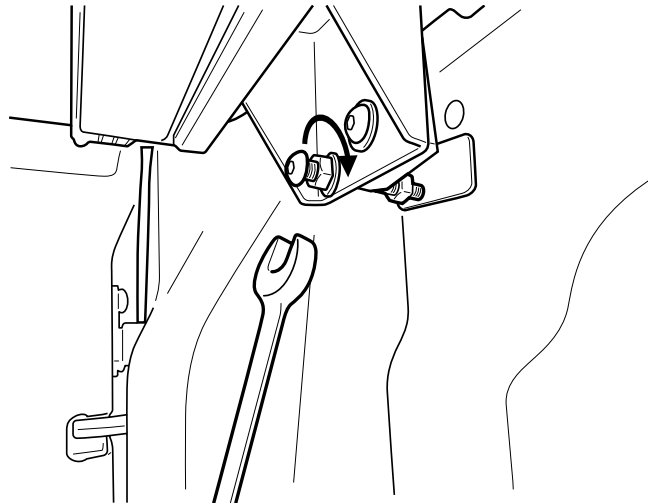

Install front drain pipes through pre-drilled holes of the canister. (RHS/LHS)



Note: With care push tube in.
Taking care pull the tube back
so it seals correctly against
the front panel of the tub.

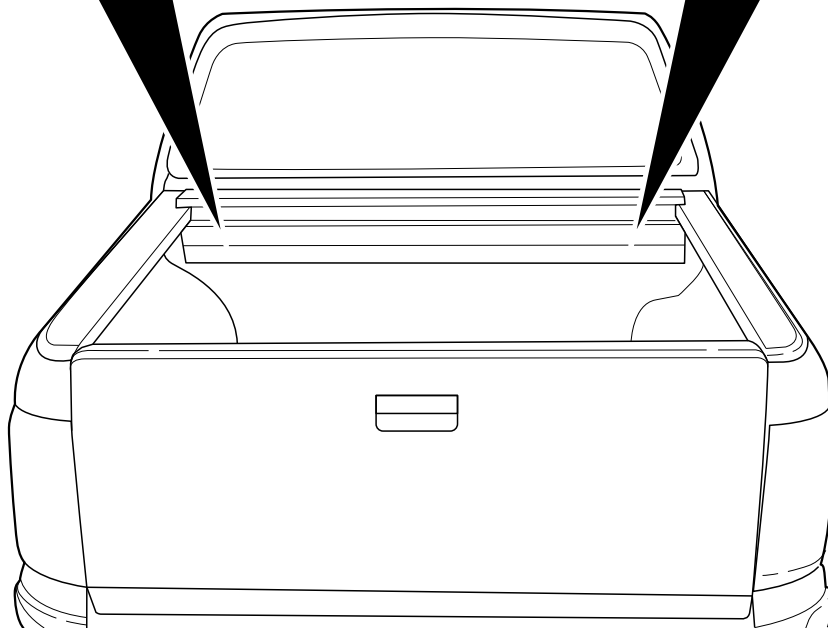
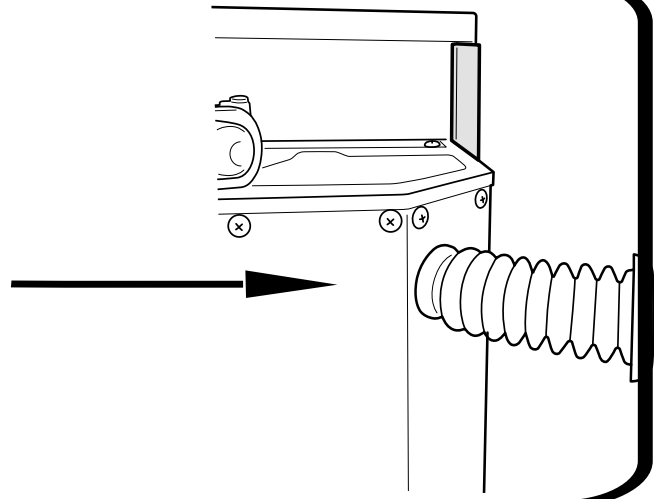
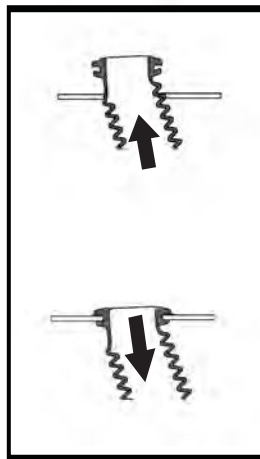

Sealing any gaps on the bed, FBA and side rails. It is recommended to use black sealant.

Apply an adequate amount of sealant to the areas indicated, then smooth sealant out.

Clean any excess sealant.

Repeat to the other side.

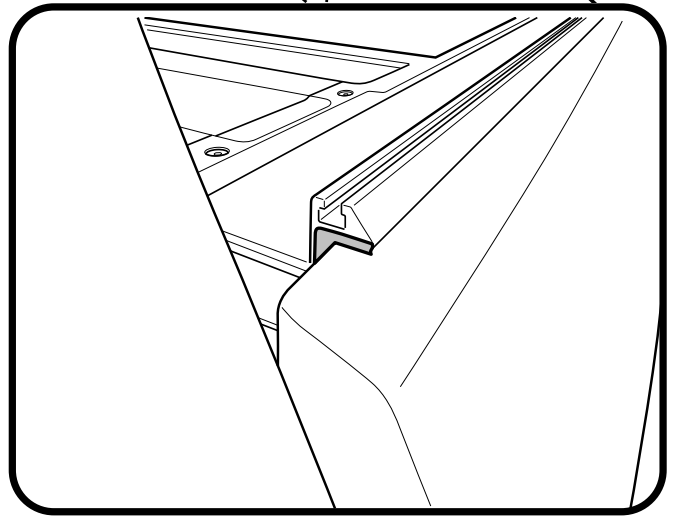
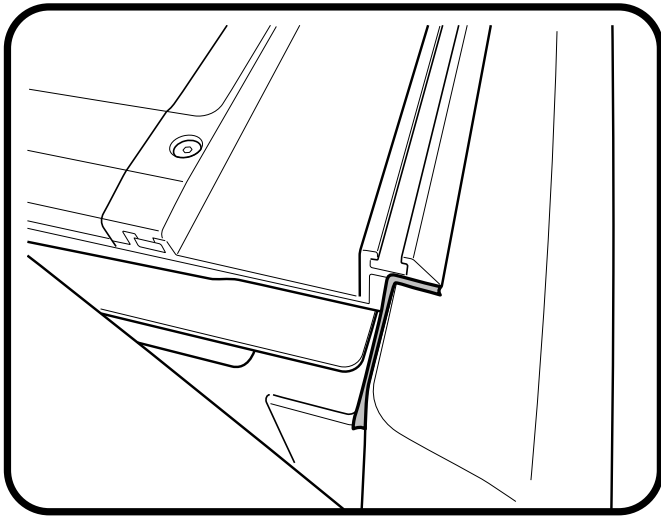
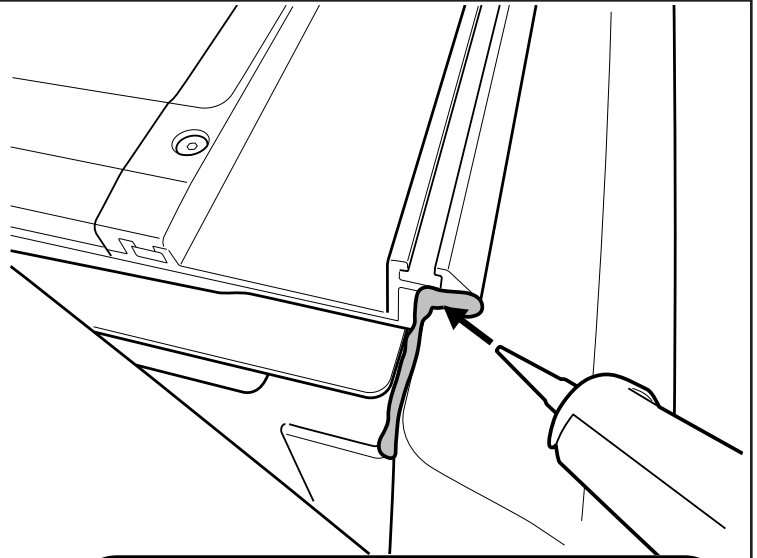

Clean area indicated with alcohol based wipe.

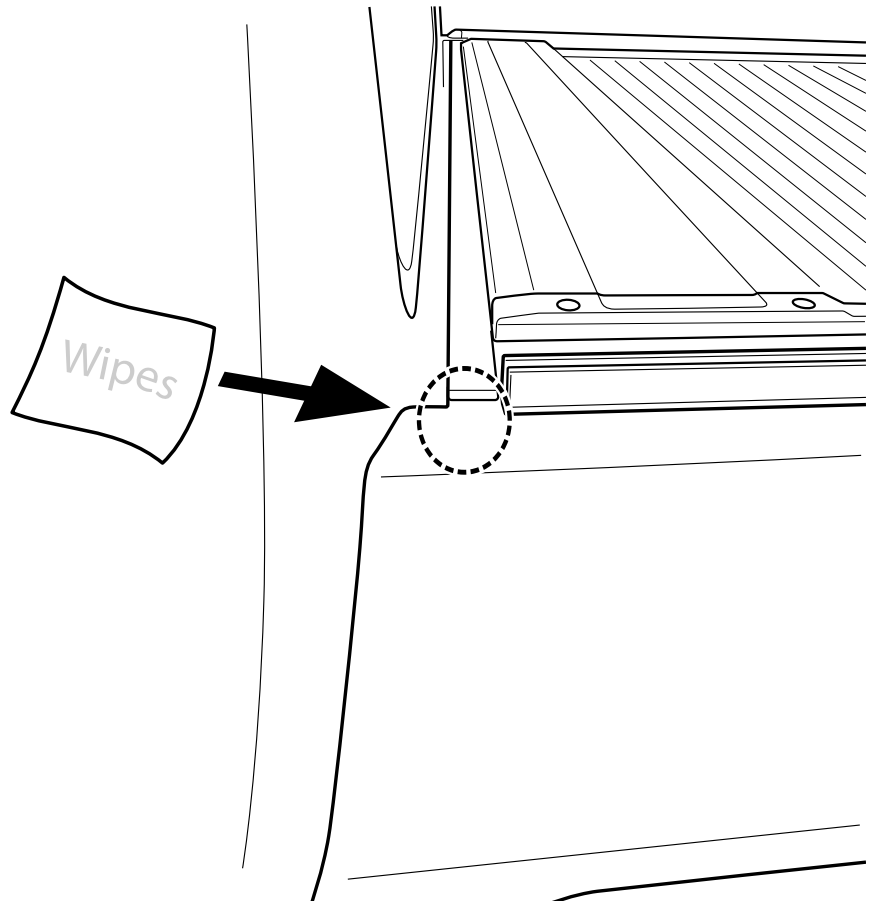

Apply 3mm primer to the indicated area.

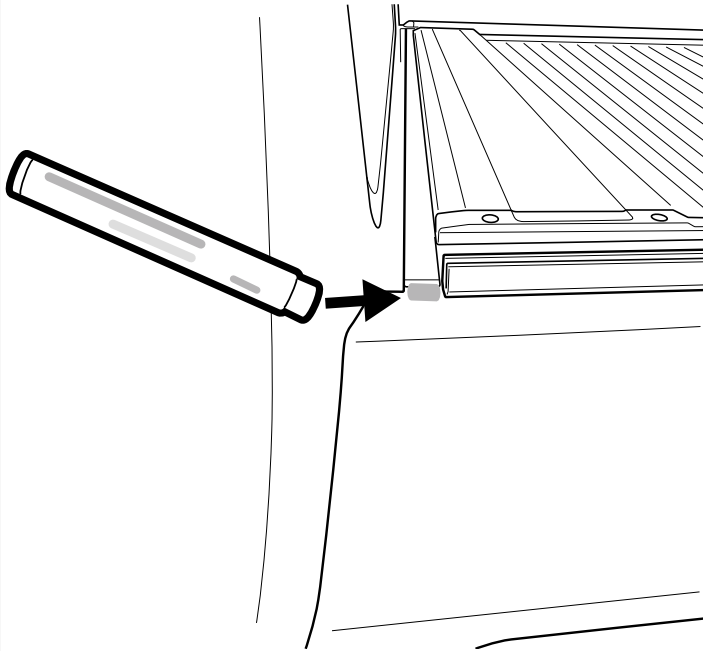

1. Lift track rubber seal up slightly as indicated.
2. Peel red film away from double sided tape of the rubber end cap as indicated and slide into the side rail cavity.

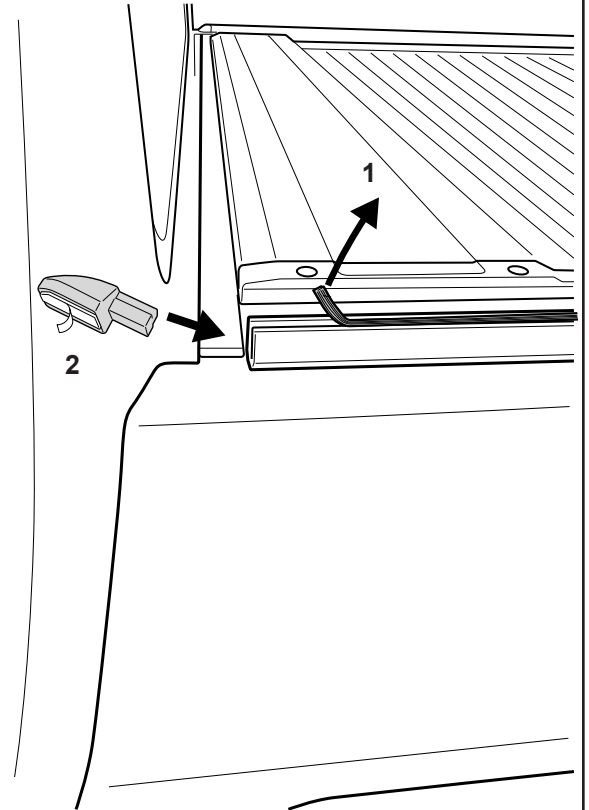

Push in into cavity firmly.

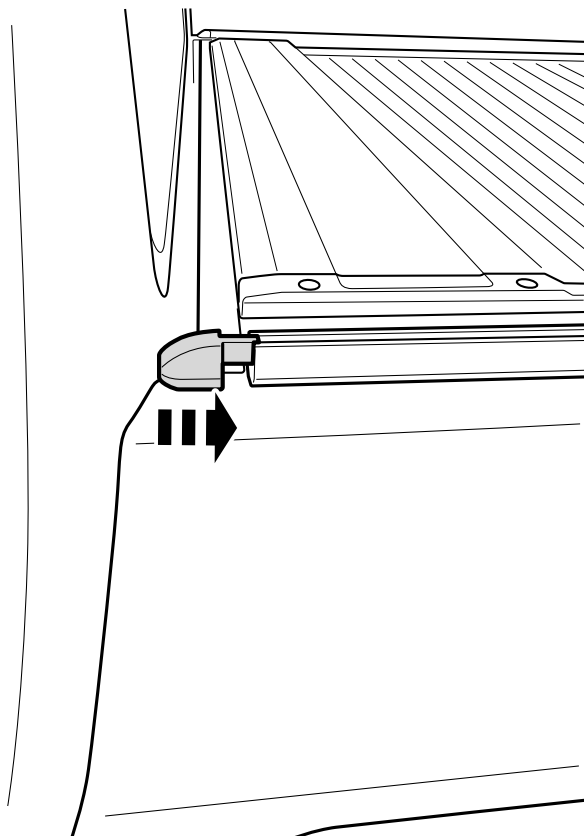

1. Push down and hold for double sided tape to bond onto the tub.
2. Trim rubber seal accordingly and fit snug against rubber end cap

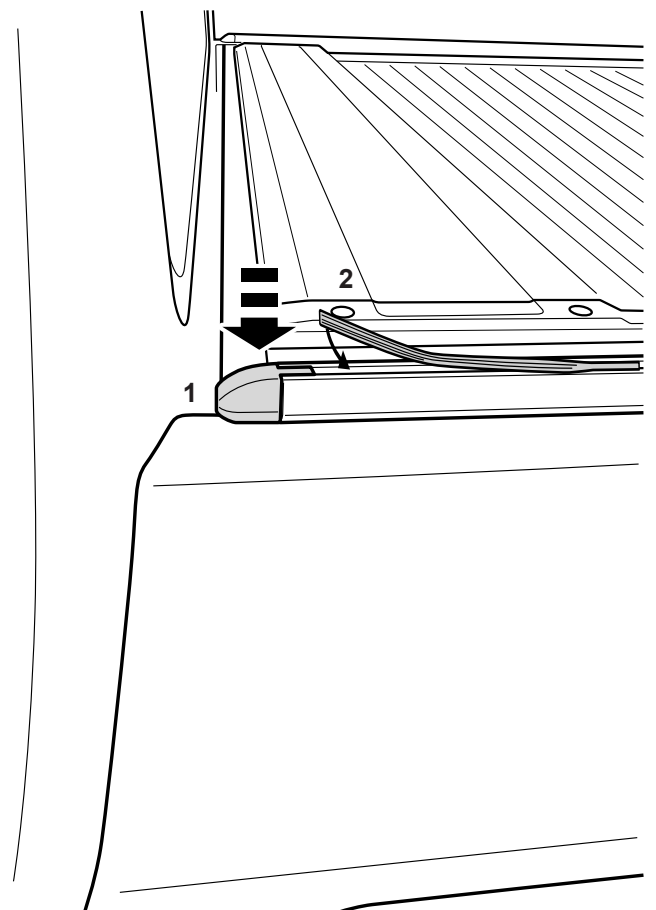

- a. Connect Battery loom S2.75 to Receiver loom.
- b. **Carefully** connect CI-Loom-short to Receiver loom.



Align connectors carefully to avoid pushing pins out.

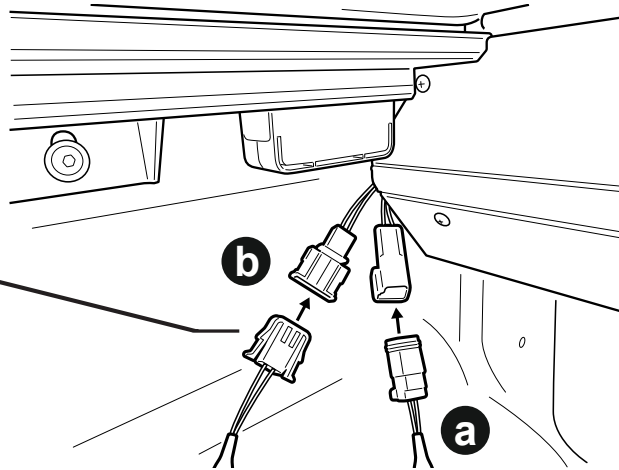

NOTE: 1. To wear in the Roll R Cover please fully open & close the cover approximately 15 times after install is complete.

2. Set your vehicle locking system to unlock all doors with one press of the factory remote unlock button. This setting can be found in your vehicle settings.

Operating instructions:

Press unlock on vehicle key fob to activate controller.

When vehicle is unlocked the side rail sensor buttons will be active to control.

When vehicle is locked the side rail sensor buttons will be inactive.

Using factory key fob to operate:

Pressing unlock twice on the factory key fob within 4 seconds, will activate the roll r cover to open.

Pressing lock twice on the factory key fob within 4 seconds, will activate the roll r cover to close.



Vehicle proximity:

Tapping the proximity twice to open or lock the car door will act exactly the same way as the key fob being pressed twice.

Touch & let go to open, touch & let go again to pause.

Touch & let go to close, touch & let go again to pause.

