



WWW.HSPUTELIDS.COM

1300 441 498

Part No: Q18

Fitting Time: 45mins



MITSUBISHI TRITON MQ

HSP TAIL LOCK

---

FITTING INSTRUCTIONS

## —GENERAL NOTES

---

- Read through the fitting instructions prior to installation of accessory.
- Ensure all recyclable components and packaging are discarded and recycled following local recycling regulations.
- Safely store and protect any removed vehicle components.

## —SAFETY NOTES

---

- Check that all work practices comply with safety standards.
- Please wear appropriate clothing and use safety equipment.

## —FITTING TIME

---



45mins

## —PARTS SUPPLIED

---

Part Description	Part Number	Quality/ Length	CHECK LIST
<b>TAIL LOCK ASSEMBLY</b>			
Main Bracket	Q18-A	1	
Tube	Q18-B	1	
Actuator	ACT-01	1	
Wiring	CL-LOOM-LONG	1	
Patch Harness	Q-PATCH	1	
<b>FASTENERS</b>			
Actuator	36	2	
Spring Washer	13	2	
<b>OTHER</b>			
Cable Ties		5	
Fitting Instruction		1	

— STEP 1 —

Fasten actuator to bracket as shown.

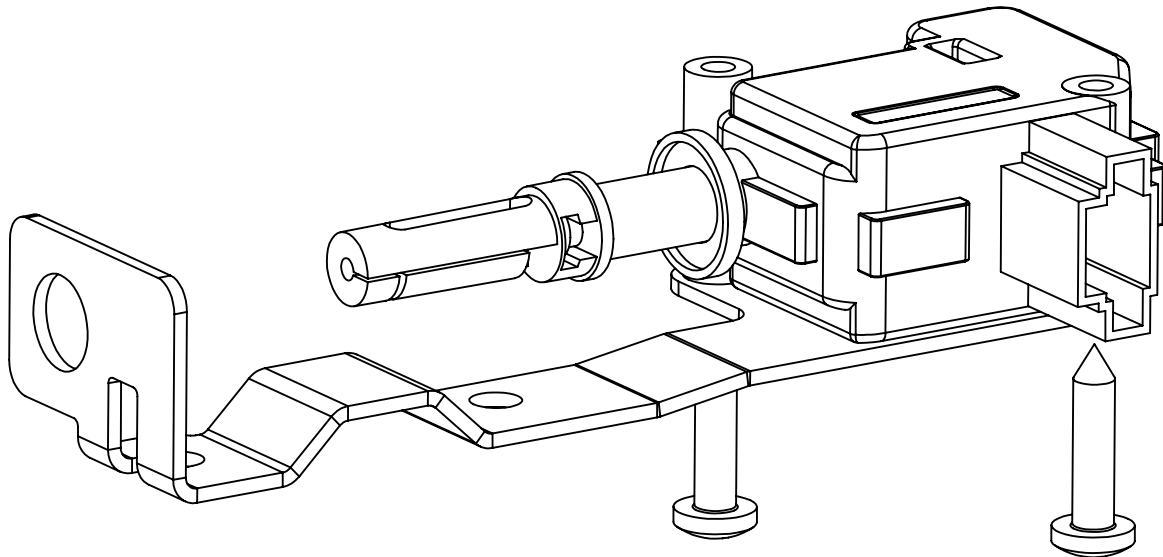

— STEP 2 —

Fit tube to actuator as shown making sure to have the end of the tube level with the main bracket.

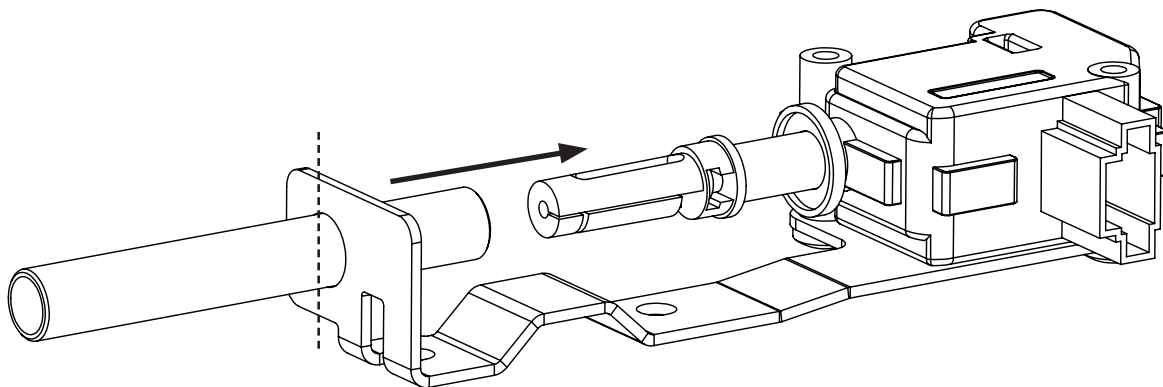

— STEP 3 —

Remove tail gate cover.

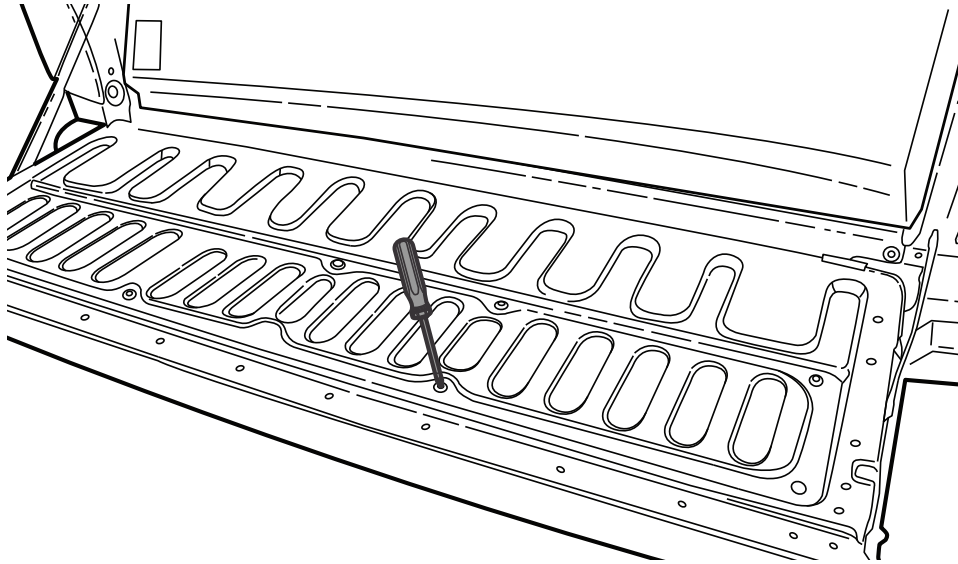

— STEP 4 —

Remove two bolts shown.

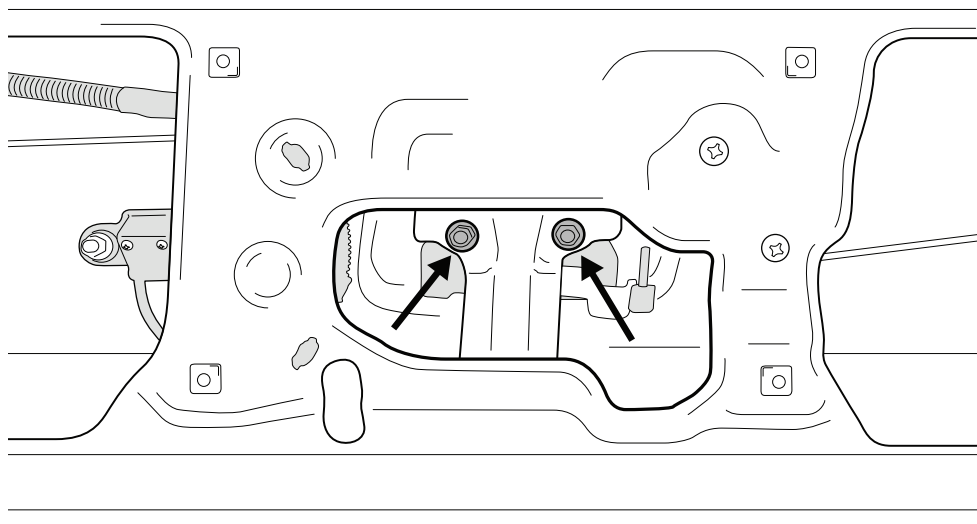

— STEP 5 —

Place spring washers in indicated position

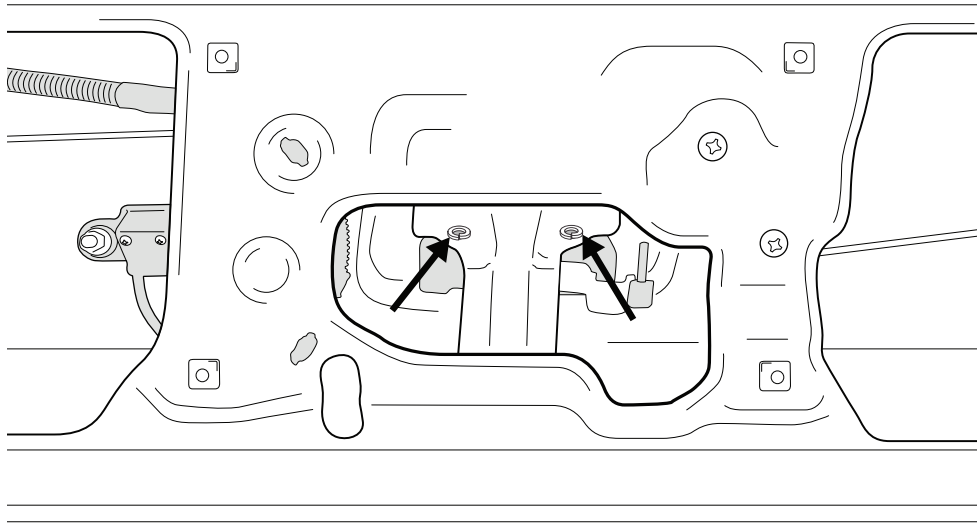

— STEP 6 —

Insert TailLock assembly as shown. Re-fasten the two bolts removed earlier.

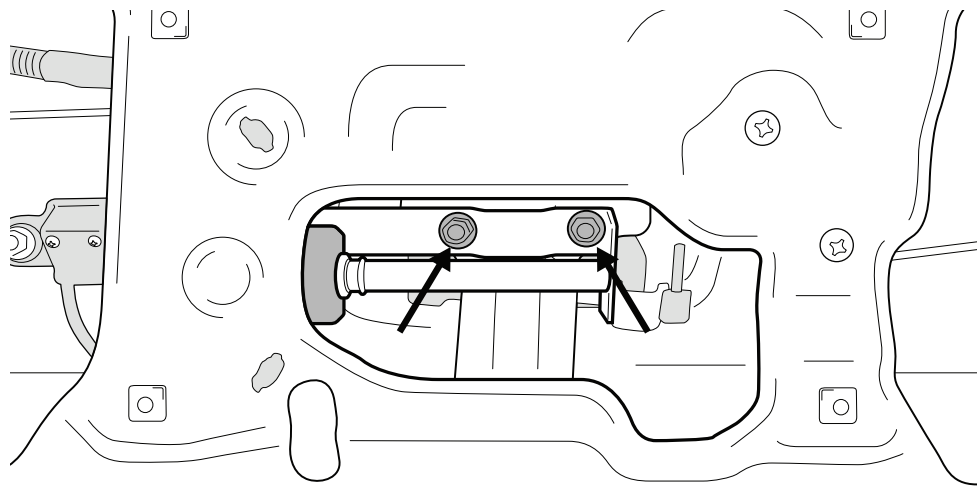

## — STEP 7 —

Remove the wiring plastic cover on the side of the tailgate.

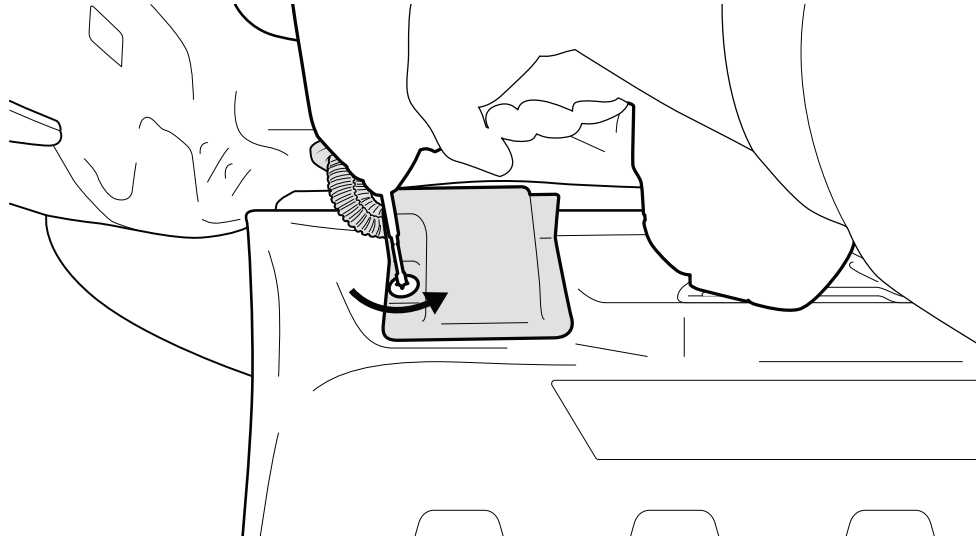

\*On base models there may not be a plastic cover or wiring running to the tailgate.

## — STEP 8 —

Run the wiring actuator end in through rubber grommet as shown. You may need to make an incision.

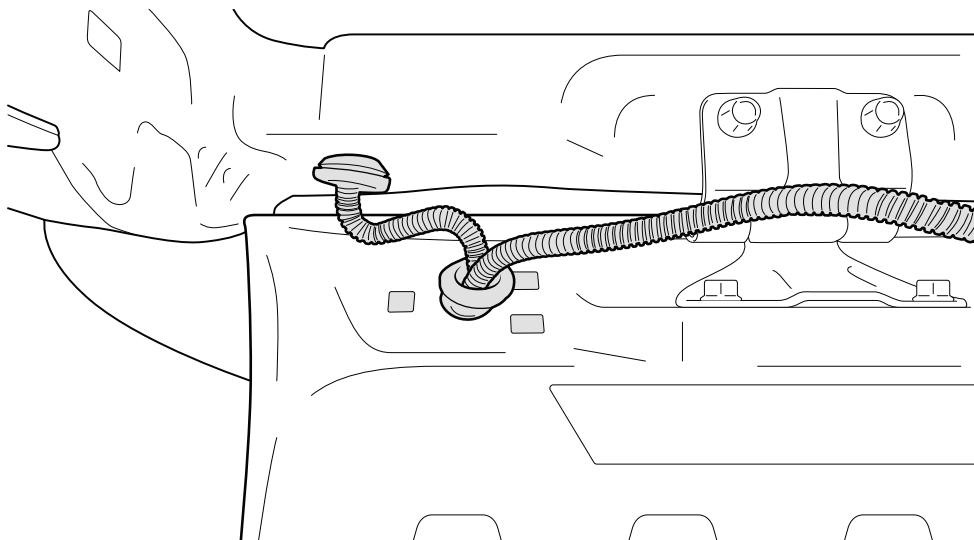

— STEP 9 —

Plug in the actuator.

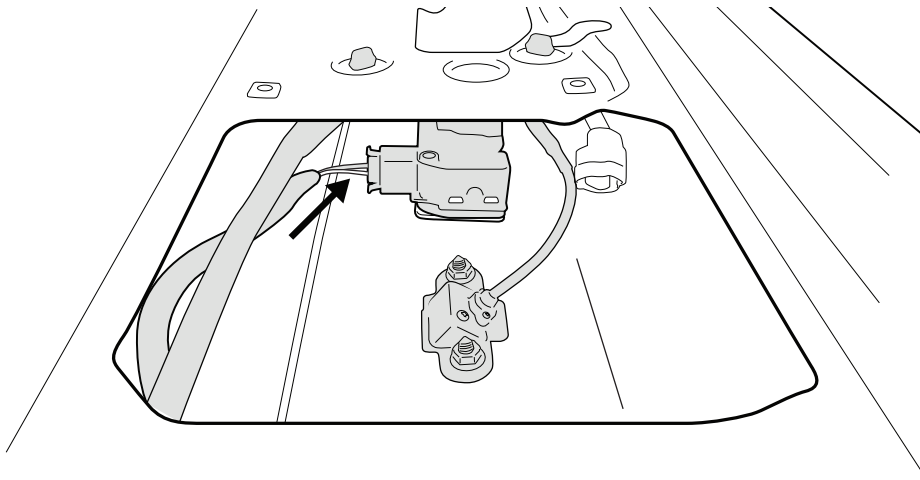

— STEP 10 —

Run the other end under the tub as shown.

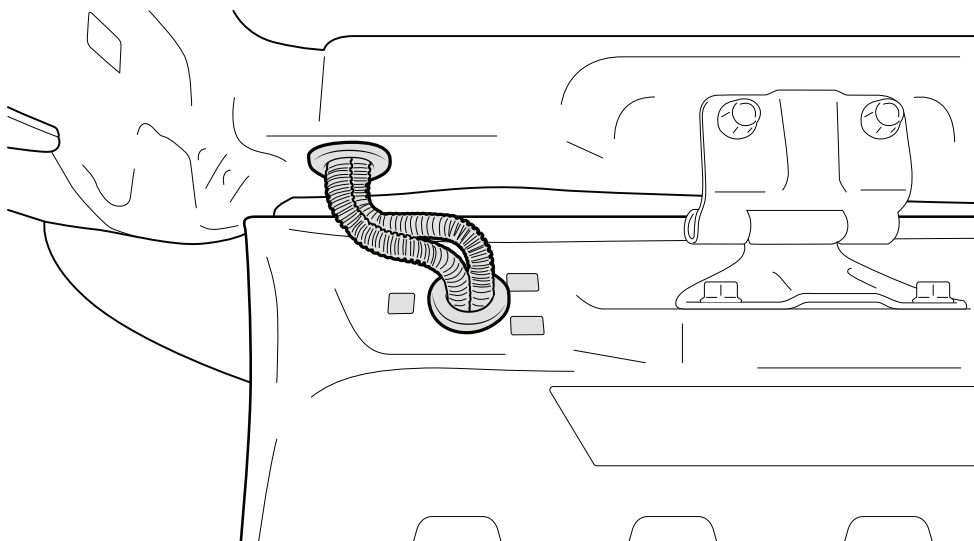

## —STEP 11

Refit the plastic cover.

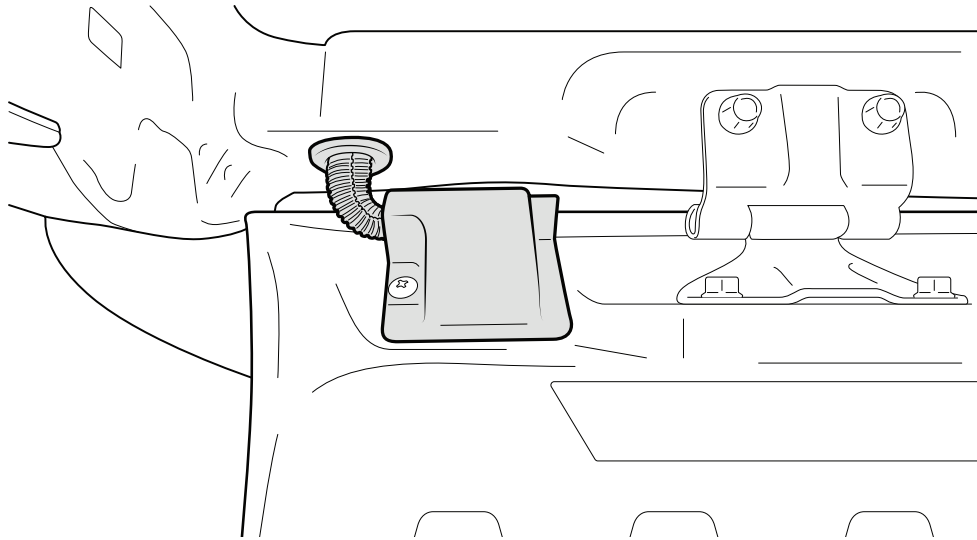

## —STEP 12

Run wiring over the passenger side rail. Cut an incision on the rubber gromit under the front passenger side seat. Run wiring through incision and silicon after. Cabel tie wiring every 500mm.

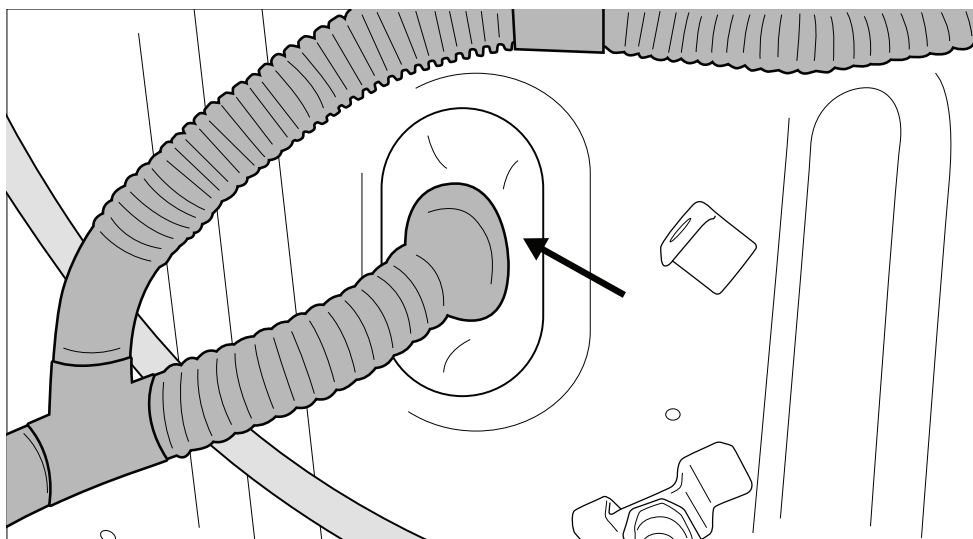



— STEP 13 —

Carefully remove the passenger side scuff plate.

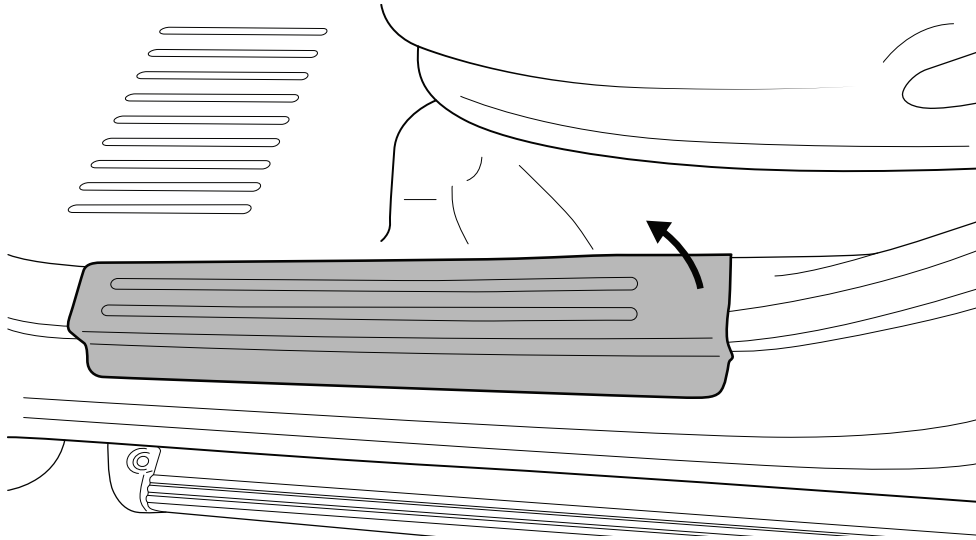

— STEP 14 —

Remove kicker panel.

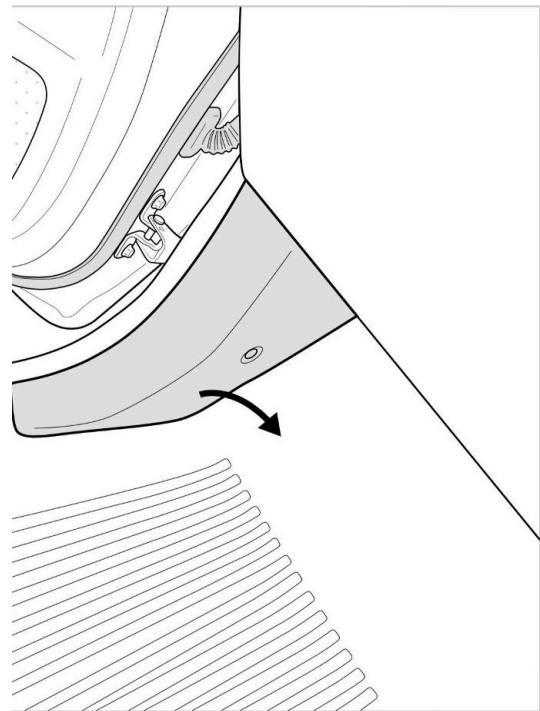

— STEP 15 —

Unplug indicated plug and plug Q-PATCH wiring.

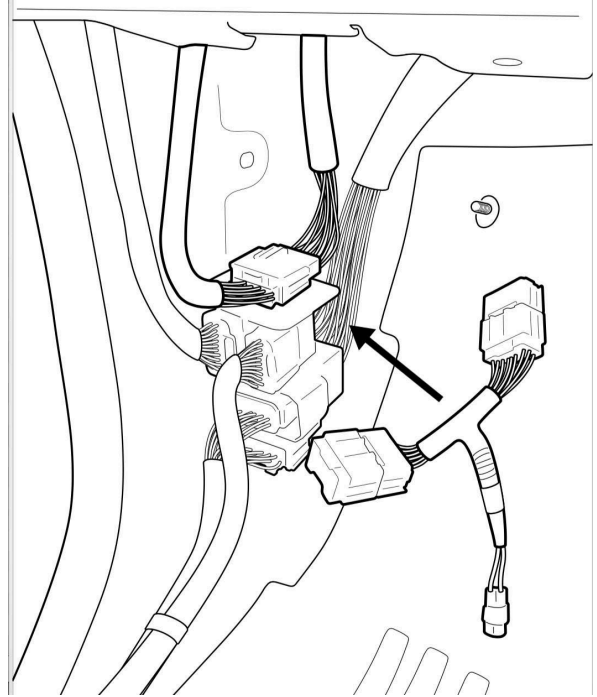

— STEP 16 —

Plug CL-LOOM-LONG to Q-PATCH wiring.

Cable tie overhang of wires and assemble all panels removed earlier.

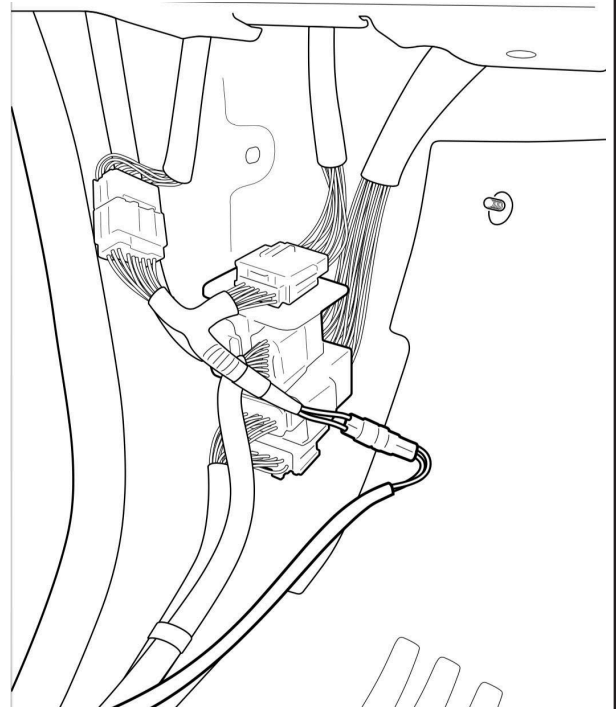

— STEP 17 —

Place and fasten tail gate cover.

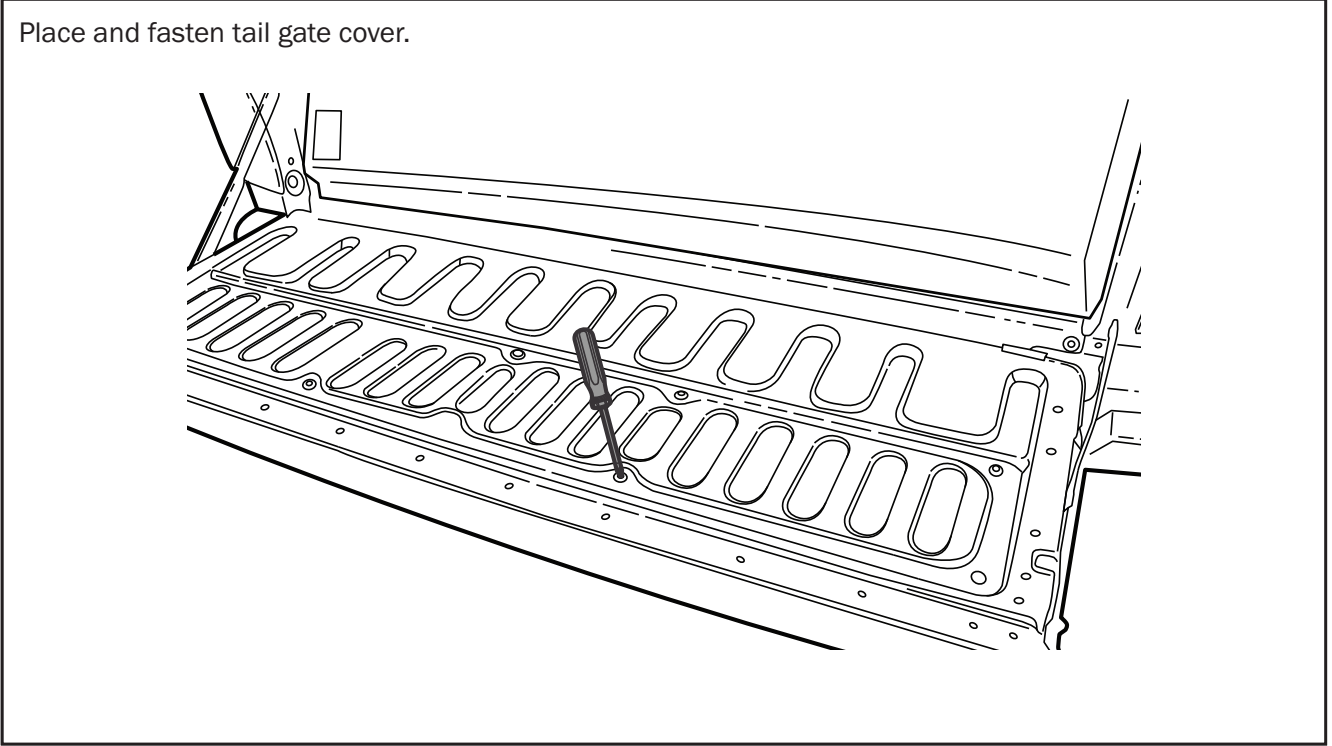

— FITTING COMPLETED —