



WWW.HSPUTELIDS.COM

1300 441 498

Part No: Q18-1

Fitting Time: 45mins



**Mitsubishi triton MR (GLS &
GLS PREMIUM)**

HSP TAIL LOCK

FITTING INSTRUCTIONS

—GENERAL NOTES

- Read through the fitting instructions prior to installation of accessory.
- Ensure all recyclable components and packaging are discarded and recycled following local recycling regulations.
- Safely store and protect any removed vehicle components.

—SAFETY NOTES

- Check that all work practices comply with safety standards.
- Please wear appropriate clothing and use safety equipment.

—FITTING TIME



45mins

—PARTS SUPPLIED

Part Description	Part Number	Quality/ Length	CHECK LIST
TAIL LOCK ASSEMBLY			
Main Bracket	Q18-1-A	1	
Tube	Q18-1-B	1	
Actuator	ACT-01	1	
Wiring	CL-LOOM-LONG	1	
Patch Harness	Q-PATCH	1	
FASTENERS			
Actuator screw	36	2	
OTHER			
Cable Ties		5	
Fitting Instruction		1	

— STEP 1 —

Using a heat gun, warm up the plastic striker of the actuator (A), then insert into the tube (B) of the actuator as shown, please make sure there is no gap between the tube and end of striker.

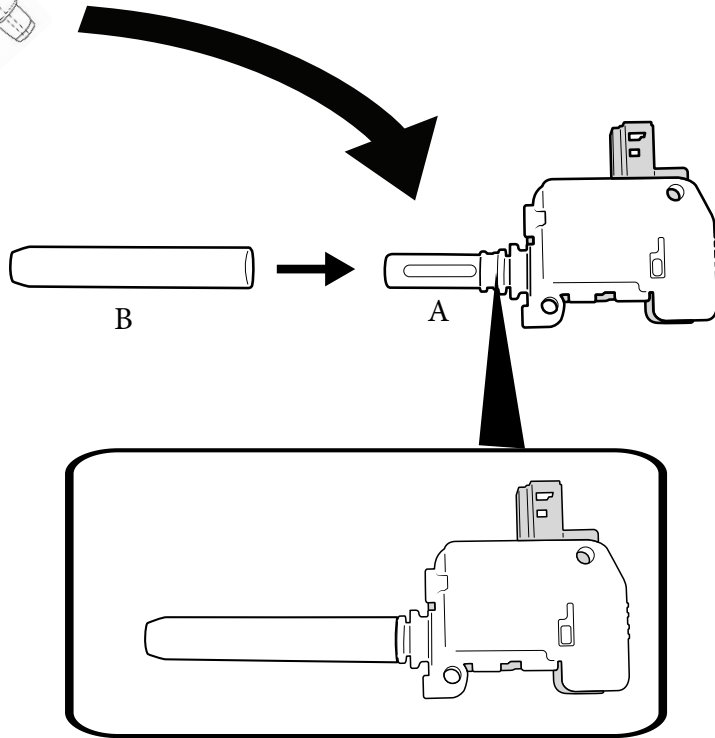
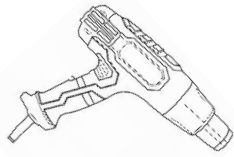

— STEP 2 —

Slidetube through the slot on the main bracket, then line up actuator with mounting holes.

Mount the actuator to the main bracket using the screws provided

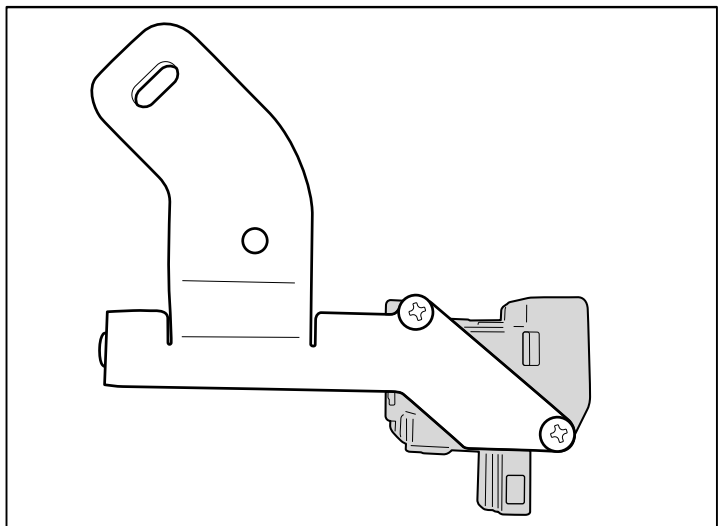
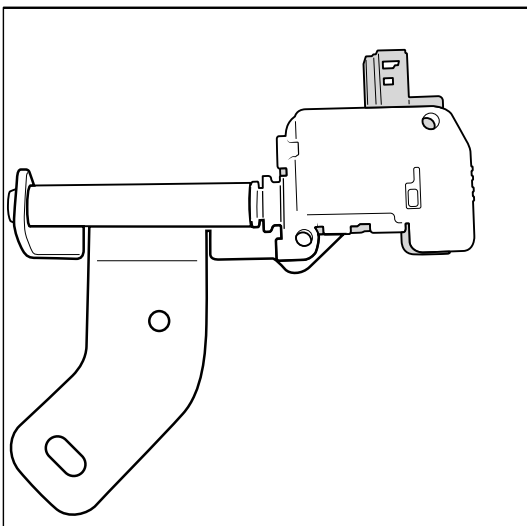

— STEP 3 —

Remove tail gate cover.

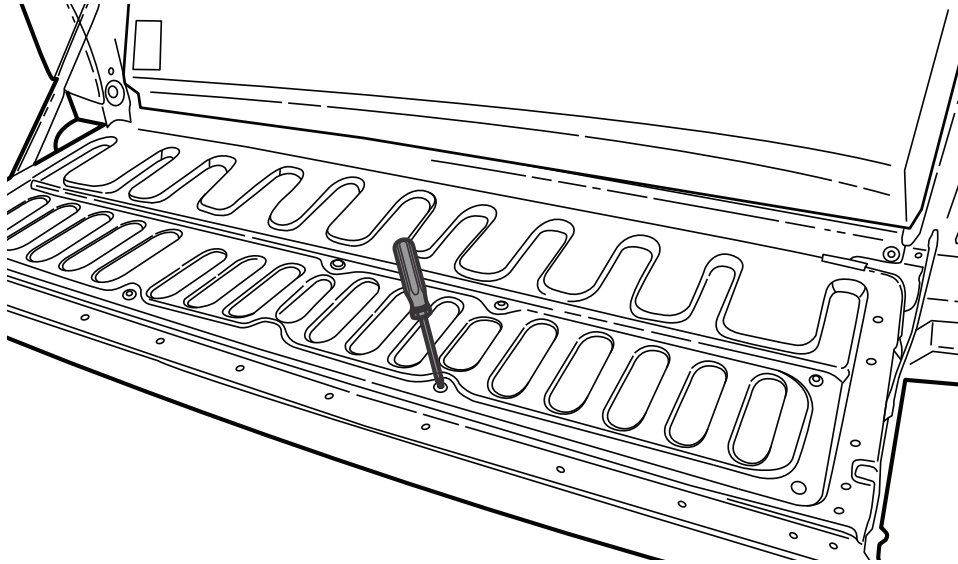

— STEP 4 —

Remove two factory screws, so it can drop the cam underneath

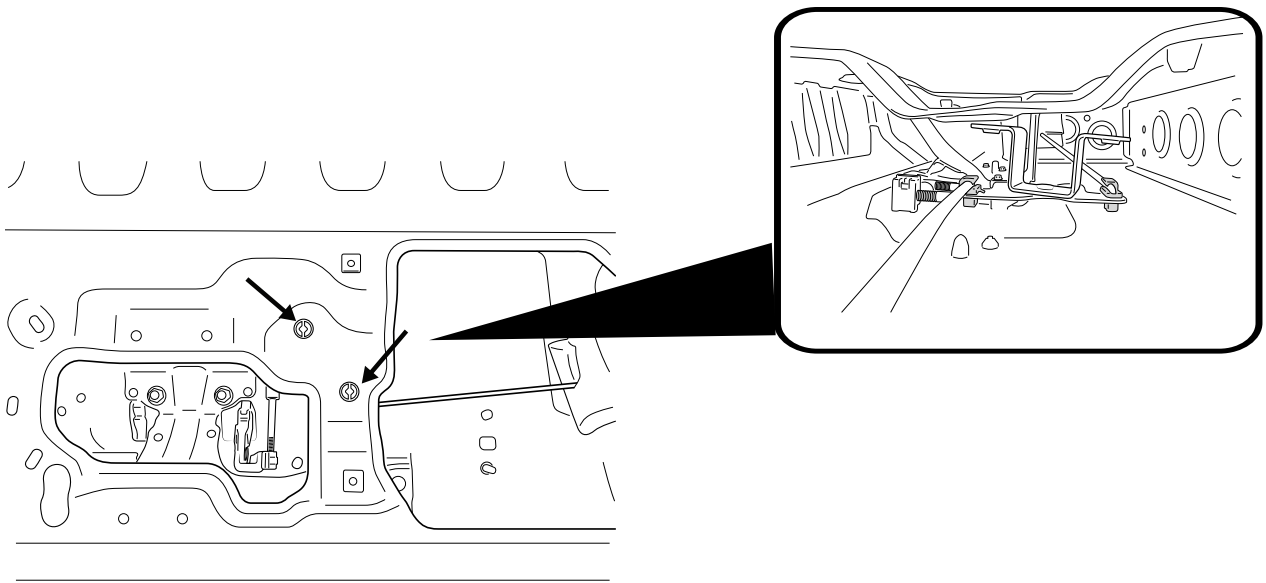

— STEP 5 —

Place the taillock assembly in between the tailgate inner skin and the factory cam. Line up taillock main bracket with the factory bracket and loosely fit in the factory screws.

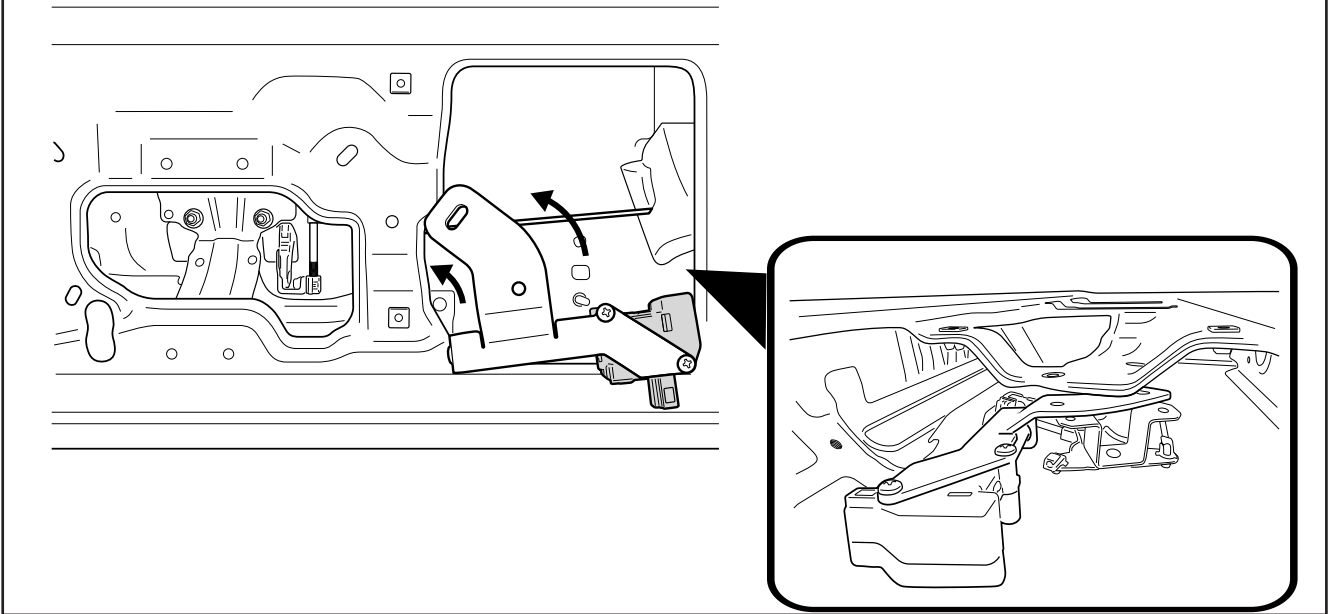

— STEP 6 —

Adjust the tail lock striker to sleeve over the handle lever then tighten the screws.

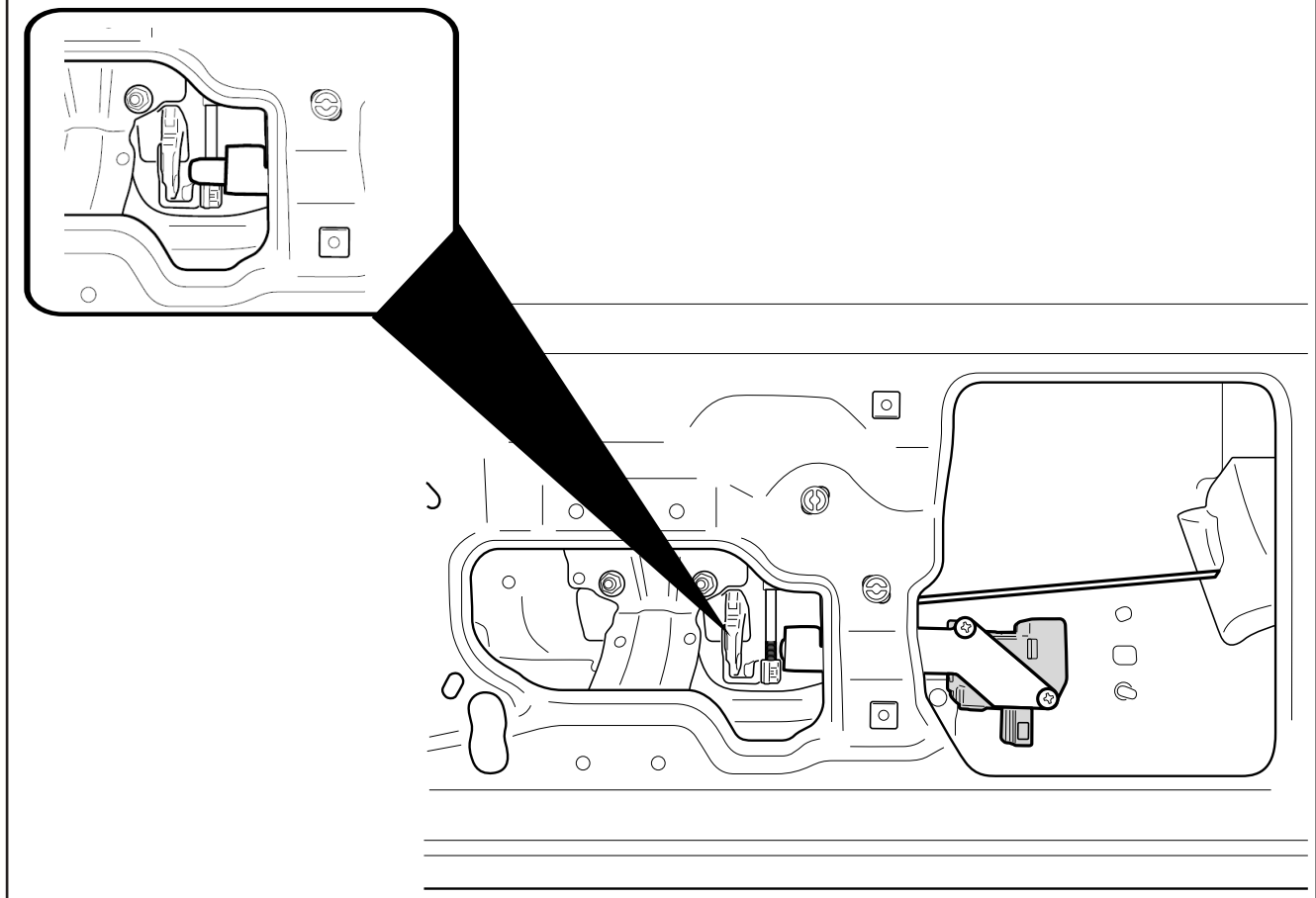

— STEP 7 —

Remove the wiring plastic cover on the side of the tailgate.

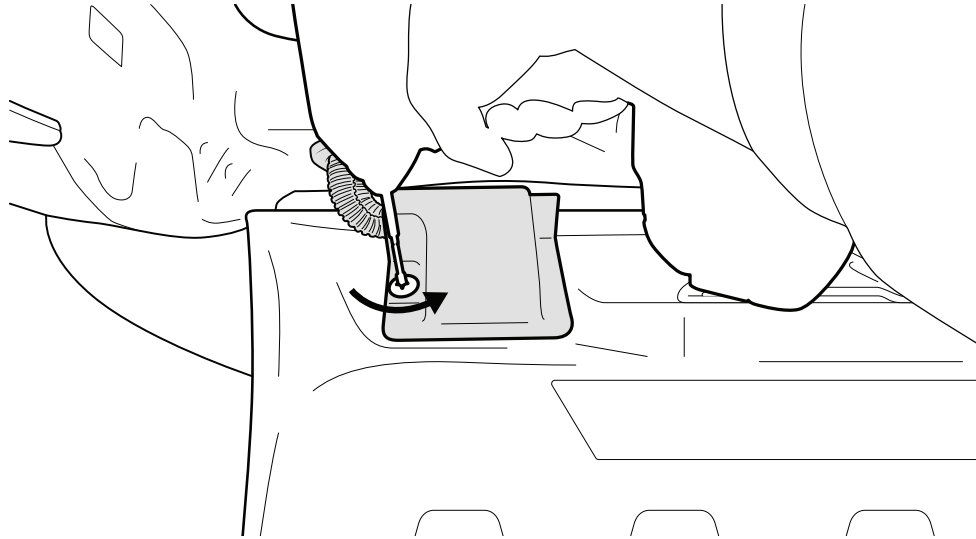

*On base models there may not be a plastic cover or wiring running to the tailgate.

— STEP 8 —

Run the wiring actuator end in through rubber grommet as shown. You may need to make an incision.

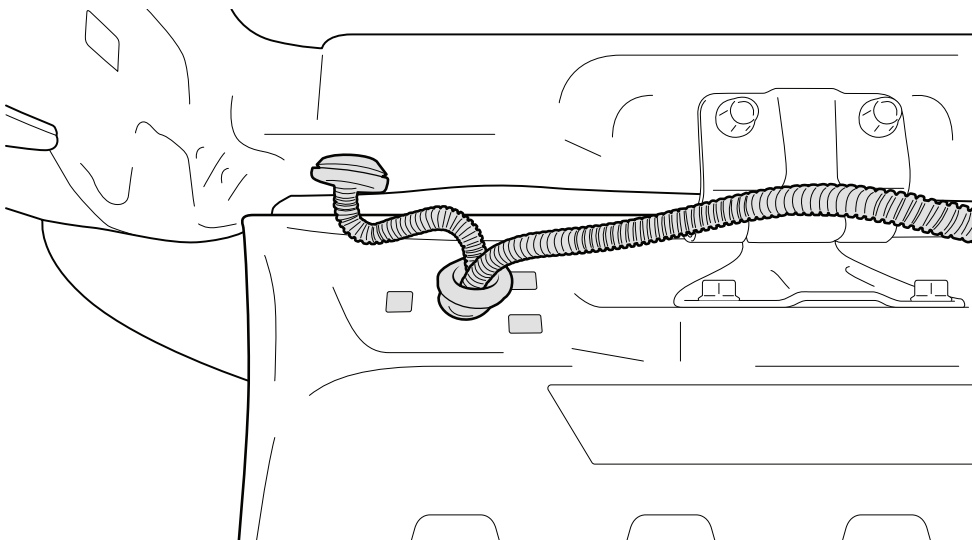

— STEP 9 —

Plug in the actuator.

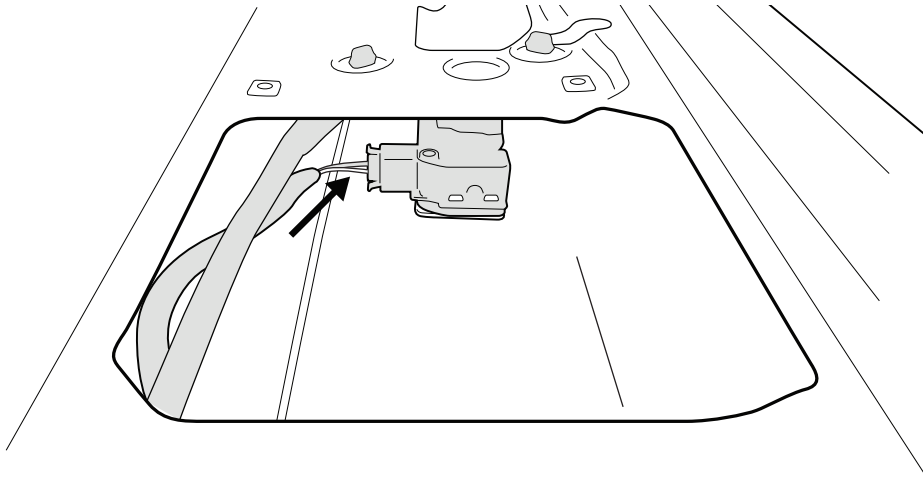

— STEP 10 —

Run the other end through and under the tub as shown.

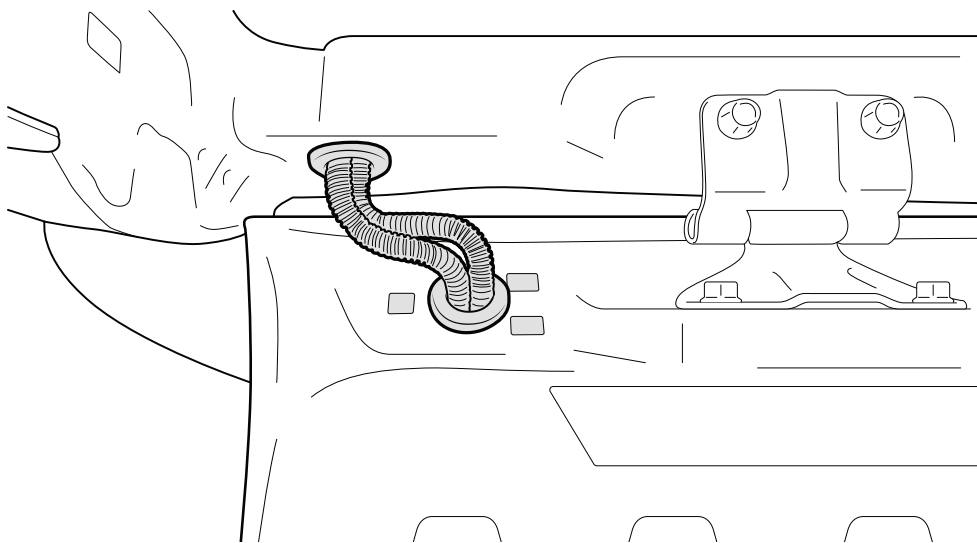

—STEP 11

Refit the plastic cover.

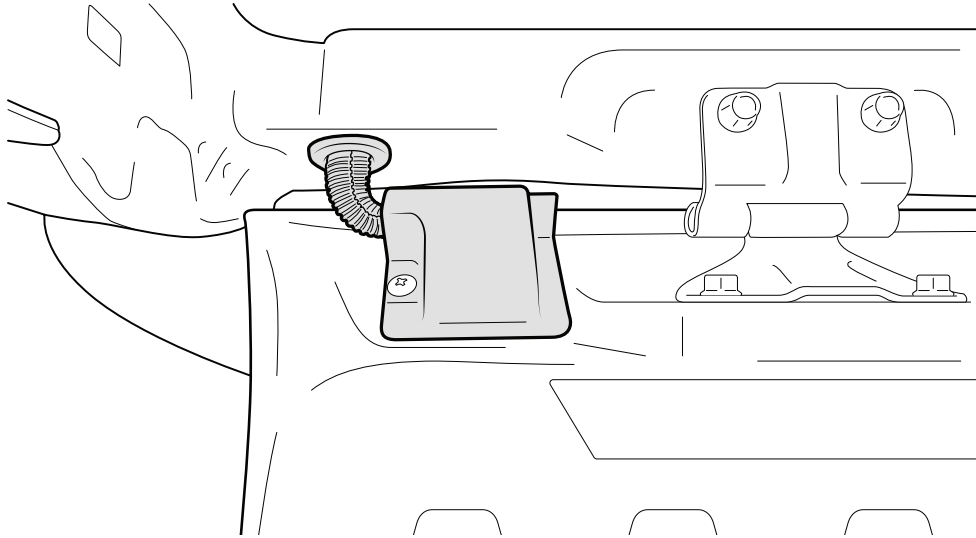

—STEP 12

Run wiring over the passenger side rail. Cut an incision on the rubber grommet under the front passenger side seat. Run wiring through incision and silicon after. Cable tie wiring every 500mm.

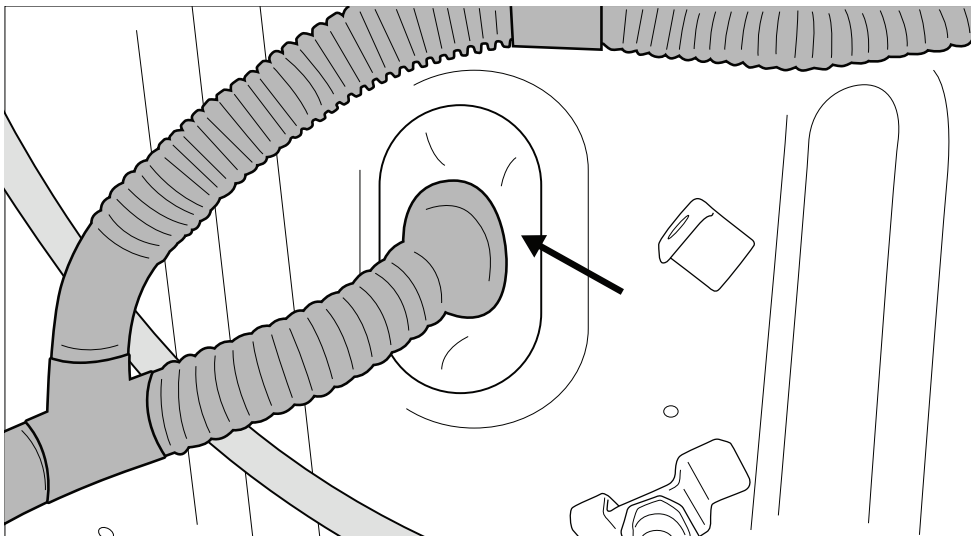

— STEP 13 —

Carefully remove the passenger side scuff plate.

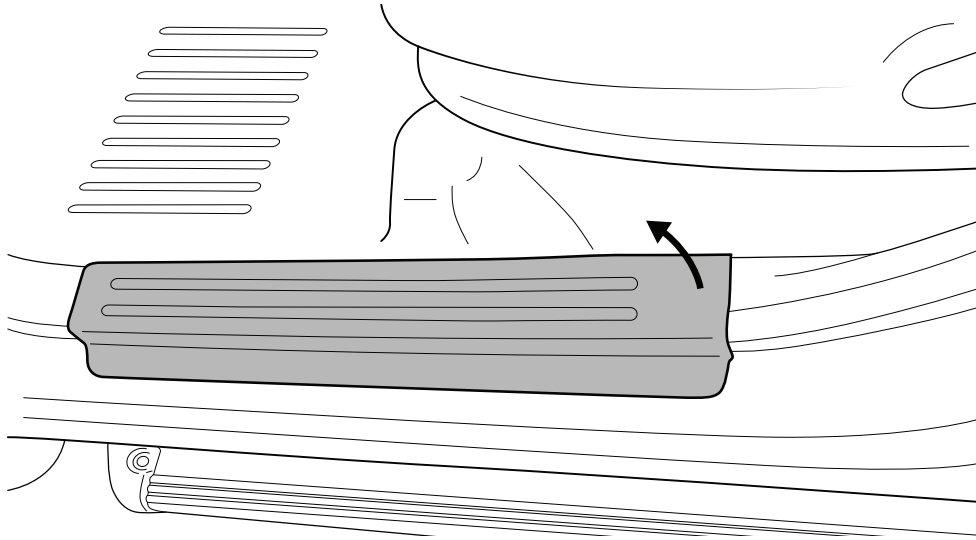

— STEP 14 —

Remove kicker panel.

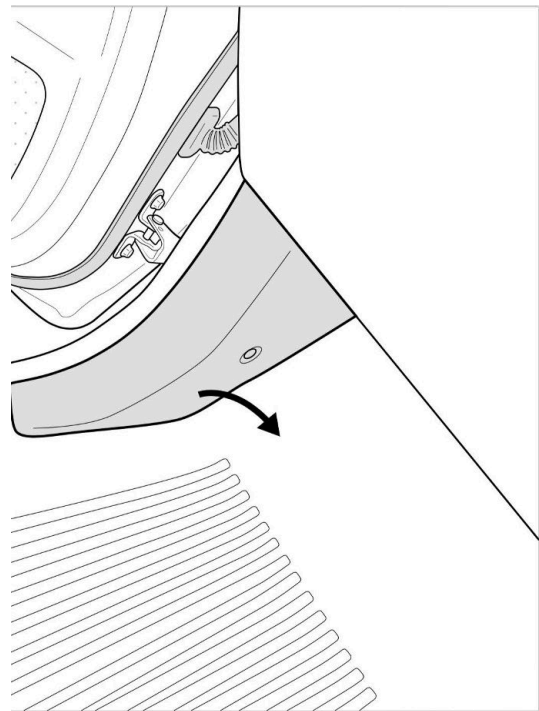

— STEP 15 —

Unplug indicated plug and plug Q-PATCH wiring.

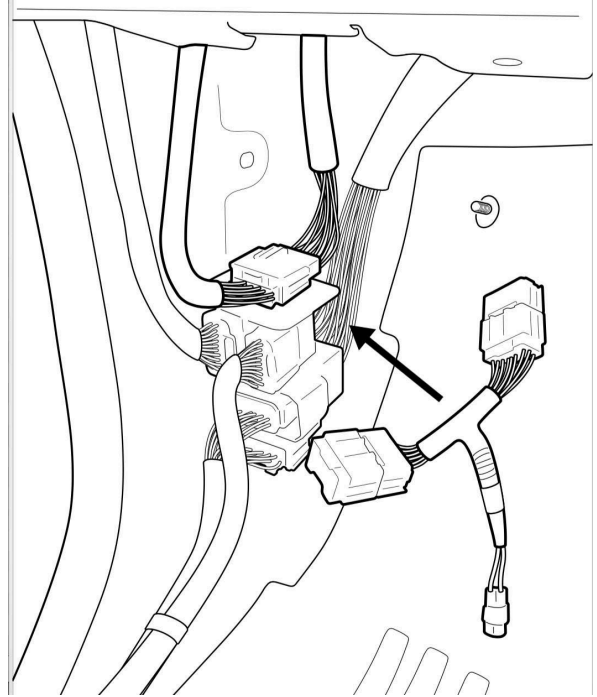

— STEP 16 —

Plug CL-LOOM-LONG to Q-PATCH wiring.

Cable tie overhang of wires and assemble all panels removed earlier.

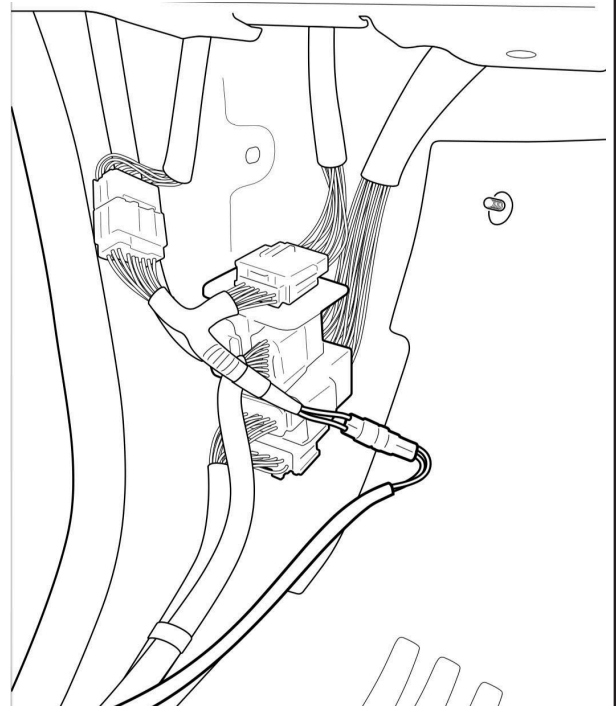

— STEP 17 —

Place and fasten tail gate cover.

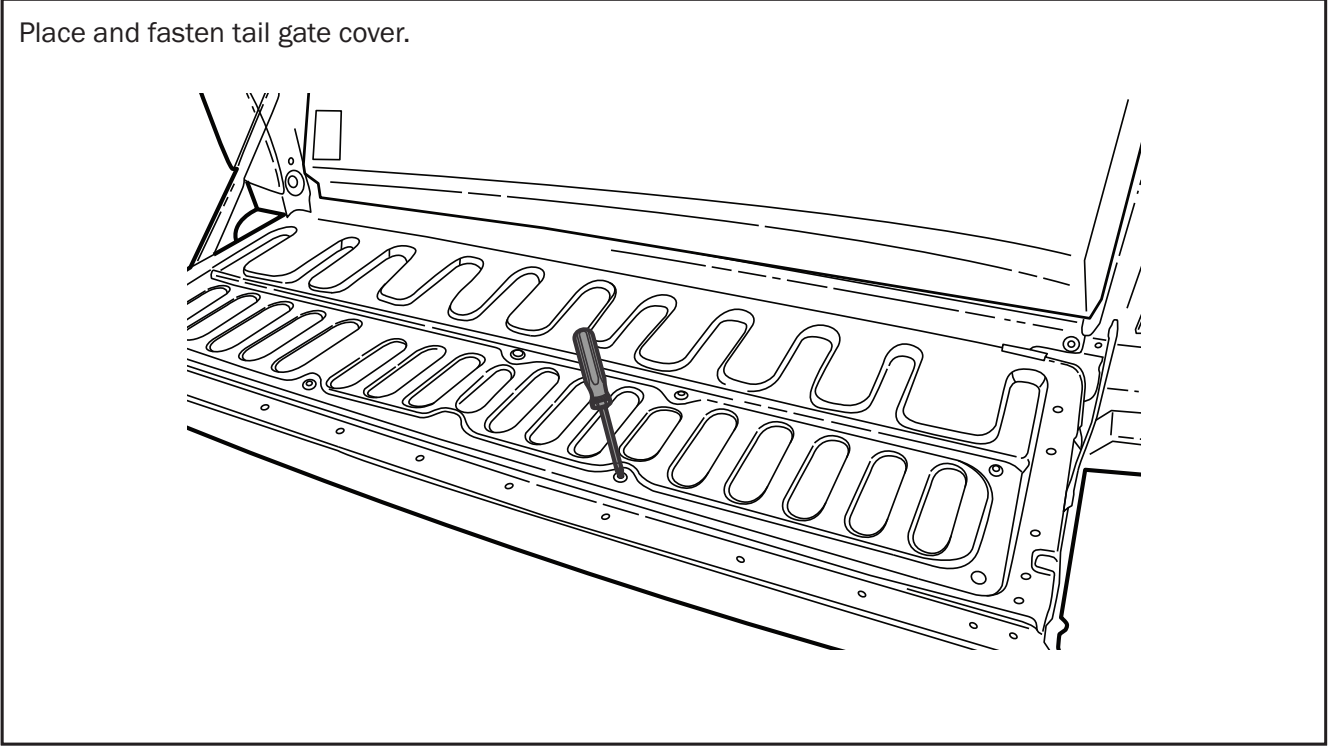

— FITTING COMPLETED —