

ARMOUR BAR FITTING INSTRUCTIONS TO SUIT PX - PU RANGER & RANGER RAPTOR

Check contents of kit before commencing fitment and report any discrepancies

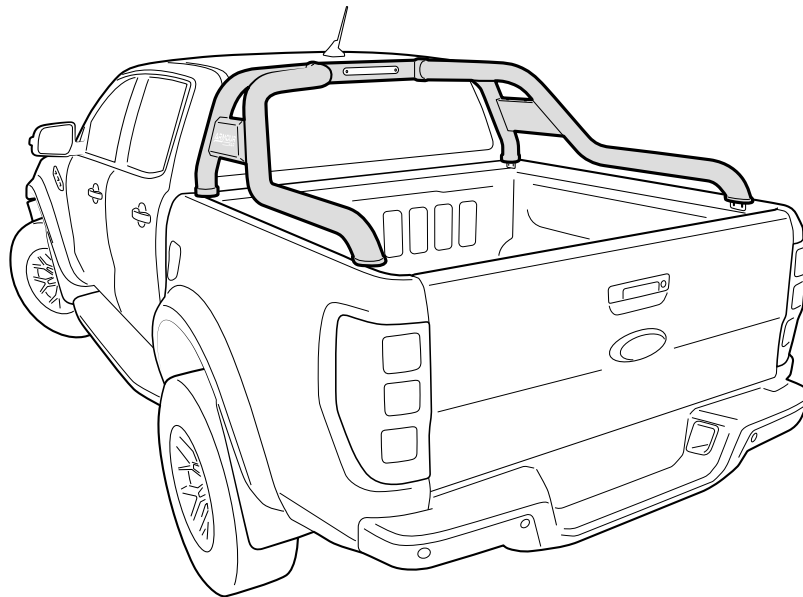

*Image example shown only

IMPORTANT	<ul style="list-style-type: none"> • Do not stand/sit or rest heavy objects on Armour bar. • Do not strap objects to the Armour bar. 			
Care Instructions	<ul style="list-style-type: none"> • Read Instructions fully before commencing installation. • Clean Armour bar with a mild detergent and water solution • Do not use abrasive cleaners or solvents • Refer to manufactures instructions applicable to power drill. • Protect Tub & tub floor against scratches during installation process. 			
Maintenance	<p>Check all fasteners regularly to make sure they are torqued up.</p>			
Tools Required	<table style="width: 100%; border: none;"> <tr> <td style="vertical-align: top;"> <ul style="list-style-type: none"> • Pen / Marker • Centre Punch • Drill & Drill bits </td> <td style="vertical-align: top;"> <ul style="list-style-type: none"> • Masking Tape • Spanner & Socket • Tape measure </td> <td style="vertical-align: top;"> <ul style="list-style-type: none"> • Soapy water solution • Allen Key set (Metric) • Test light </td> </tr> </table>	<ul style="list-style-type: none"> • Pen / Marker • Centre Punch • Drill & Drill bits 	<ul style="list-style-type: none"> • Masking Tape • Spanner & Socket • Tape measure 	<ul style="list-style-type: none"> • Soapy water solution • Allen Key set (Metric) • Test light
<ul style="list-style-type: none"> • Pen / Marker • Centre Punch • Drill & Drill bits 	<ul style="list-style-type: none"> • Masking Tape • Spanner & Socket • Tape measure 	<ul style="list-style-type: none"> • Soapy water solution • Allen Key set (Metric) • Test light 		

PARTS CHECK SHEET

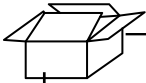

PARTS IN MAIN CARTON

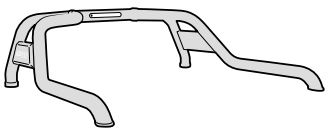

Armour Bar

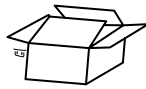

Fitting Kit
Qty - 1

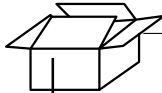

PARTS IN FITTING KIT

20040940001



FRONT TUBE ASSEMBLY

Qty - 1

20042228201



SIDE TUBE(L)

Qty - 1

20042228301

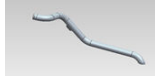

SIDE TUBE(R)

Qty - 1

20040942601



SIDE PLATE ASSEMBLY(L)

Qty - 1

20042173401

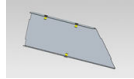

BACK COVER FOR SIDE PLATE(L)

Qty - 1

20040944101



SIDE PLATE ASSEMBLY(R)

Qty - 1

20042173501

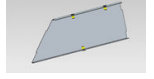

BACK COVER FOR SIDE PLATE(R)

Qty - 1

20040937601



MOUNTING BRACKET(L)

Qty - 2

20040937701



MOUNTING BRACKET(R)

Qty - 2

20008912301



JOINT RUBBERCOVER(L)

Qty - 1

20009589301



JOINT RUBBERCOVER(R)

Qty - 1

20008160801



HOLE PLUG

Qty - 2

20007045301



FRONT RUBBER FOOTING

Qty - 2

20006940201/1



REAR RUBBER FOOTING

Qty - 2

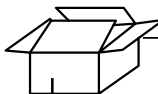

LID NUTS AND BOLTS

3005581



M10 x 60 ALLEN Head Bolt

Qty - 2

E3000145



M8 SPRING WASHER

Qty - 8

E3000233



M6 LARGE WASHER

Qty - 14

E3008096



M8 FLAT WASHER

Qty - 8

E3000325



M10 FLAT WASHER

Qty - 2

E3008183



M8 FLANGE NUT

Qty - 8

E3008066



M6 FLANGE NUT

Qty - 8

E3008107



M10 SPRING WASHER

Qty - 2

E3008109

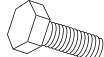

M6 HEX BOLT

Qty - 8

E3008155

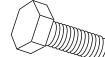

M8 HEX BOLT

Qty - 8

E3008097



M8 HEX FLANGE BOLT

Qty - 8

E3005469



M6 x 20 ALLEN Head Bolt

Qty - 6

E3008196



M6 SPRING WASHER

Qty - 6

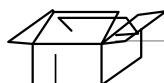

OTHER

3000062



S4 ALLEN KEY

Qty - 1

3000078



S6 ALLEN KEY

Qty - 1



Fitting Instructions
Qty - 1

Thoroughly clean installation areas.

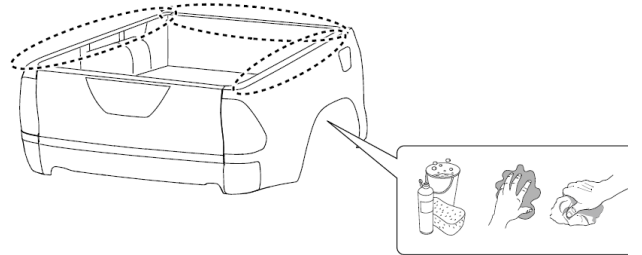

Place part number 20009589301 (JOINT RUBBERCOVER(R)) to 20040940001 (FRONT TUBE ASSEMBLY),
Repeat to the other side using part number 20008912301

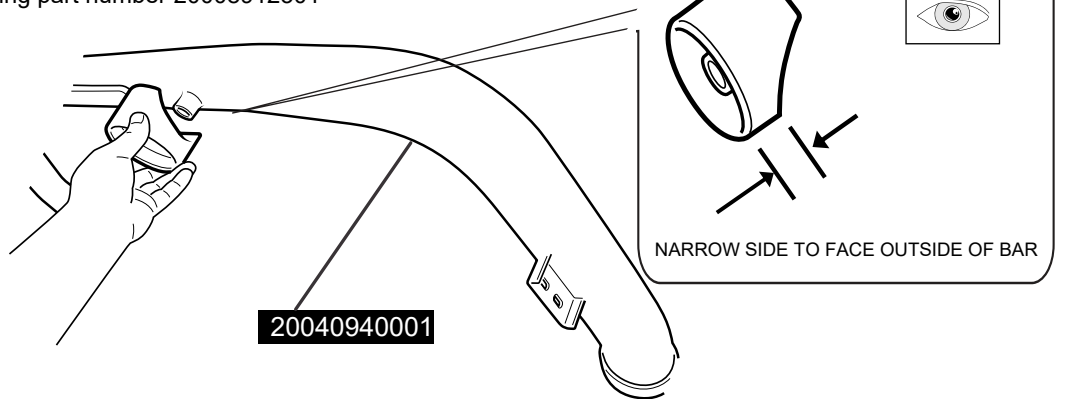

Feed into place part number 20042228301 (SIDE TUBE(R)) through 20009589301 and 20040940001.
Repeat to the other side using part number 20042228201 (SIDE TUBE(L))

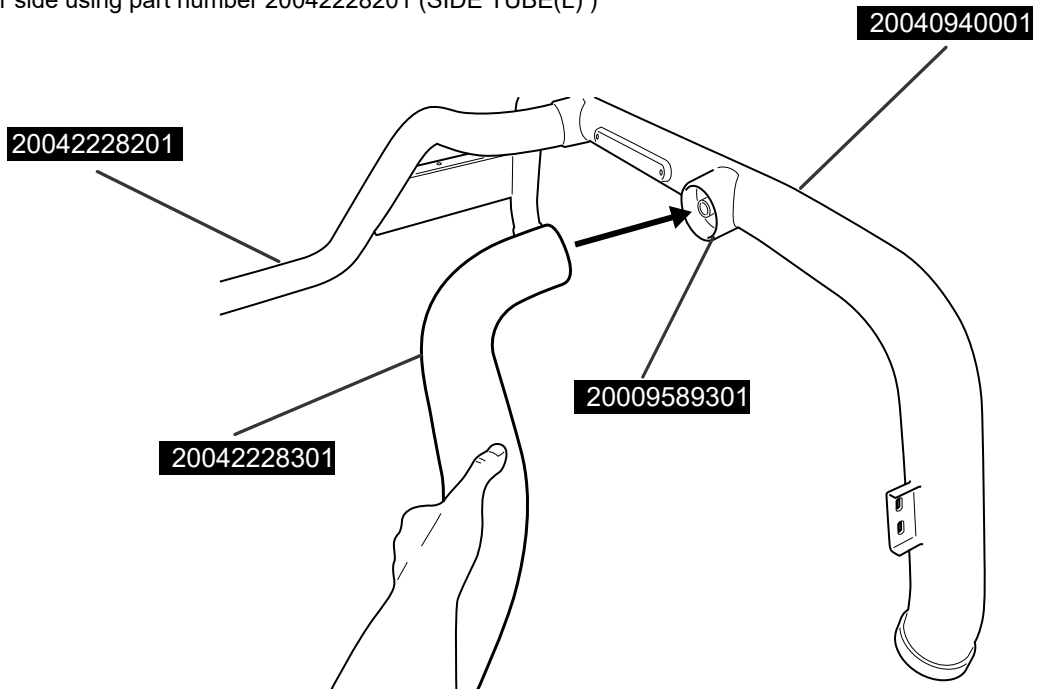

Feed part number 300558 (M10 Allen head bolt) through E3008107 (M10 spring washer) , E3000325 (M10 washer), 20040940001 (Front tube assembly) and fasten to 20042228301 (SIDE TUBE(R)). Repeat to the other side.

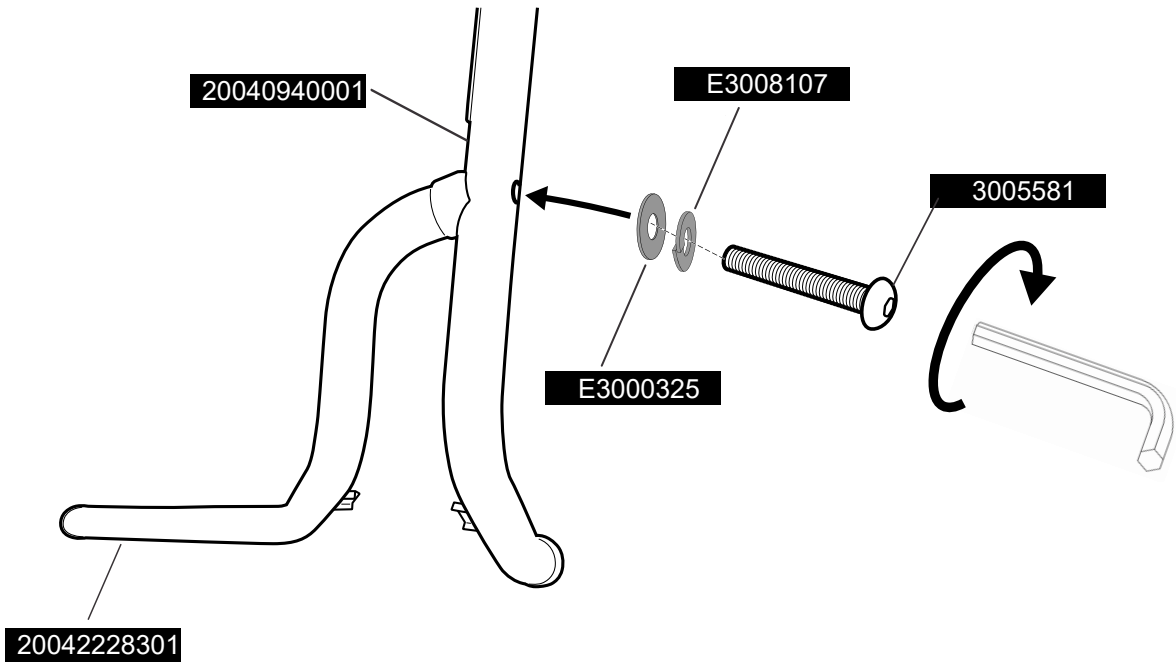

Align part number 20040944101 (side plate assembly (R)) as indicated.

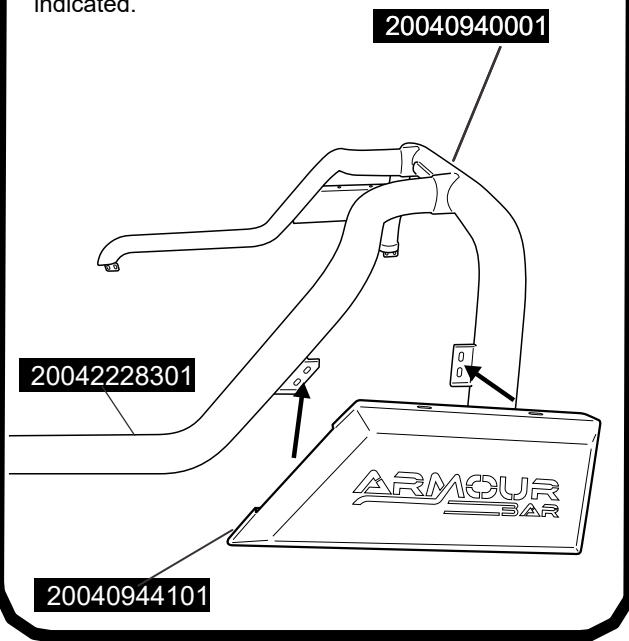

Fasten into position using, M6 Hex Flange bolt trough M6 large washer, the tube tabs, side plate tabs, & M6 Flange nut. Repeat to all 4 points.

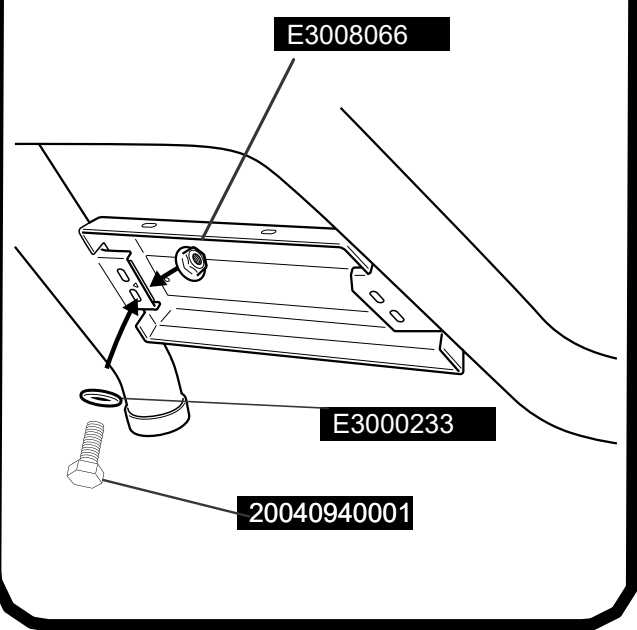

Repeat above steps to the other side using part number 20040942601 (side plate assembly (L))

Align part number 20042173501 (back cover for side plate (R)) as indicated.

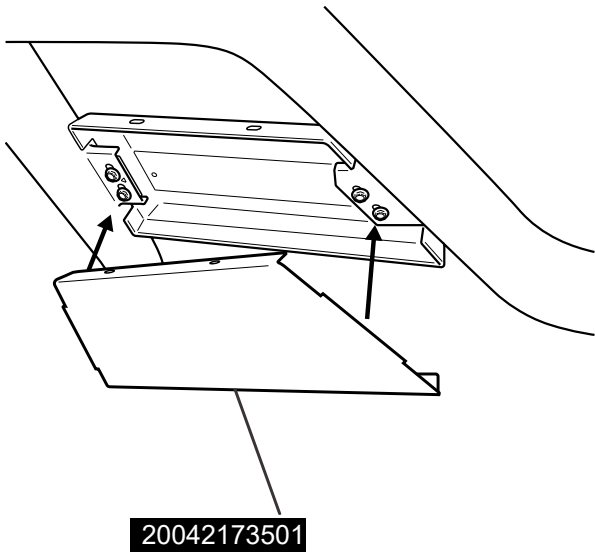

Fasten into position using M6x20 Allen head bolt through M6 spring washer and M6 large washer.

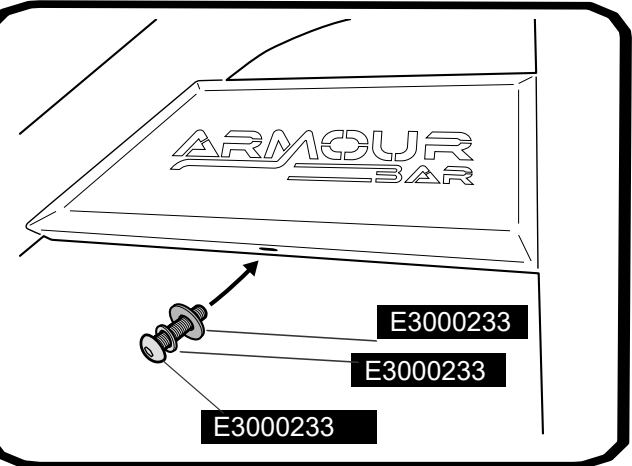
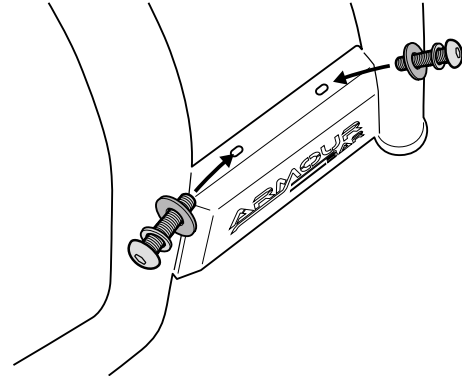

Repeat above steps to the other side using part number 20042173401 (back cover for side plate L))

Push in to position part number 20008160801 (hole plug) as indicated.
Repeat to the other side.

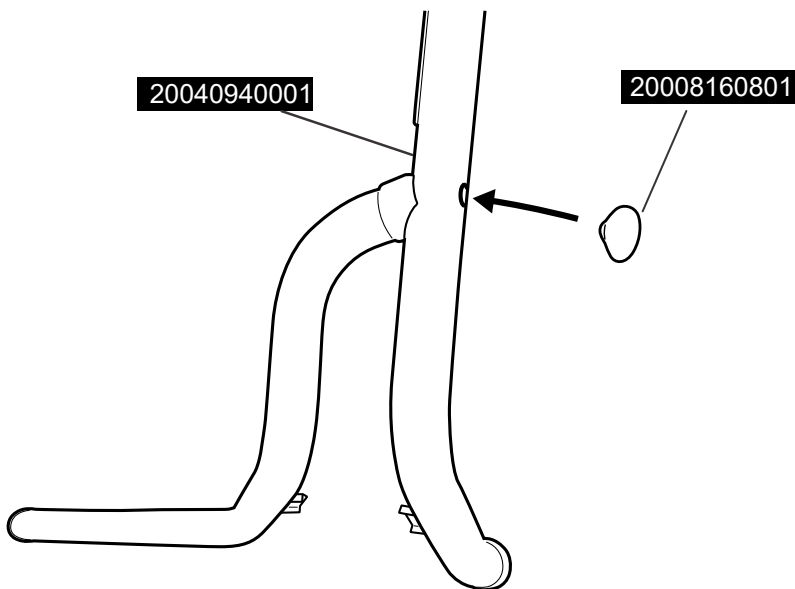

Using part number 20007045301 slide over front tube of Armour bar.

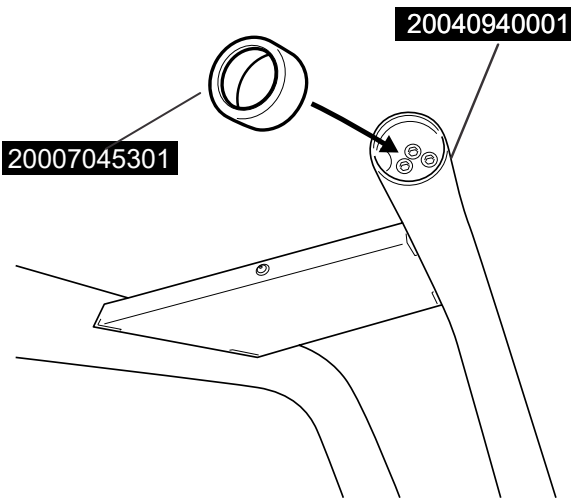

Using part number 20006940201/1 slide over front tube of Armour bar.

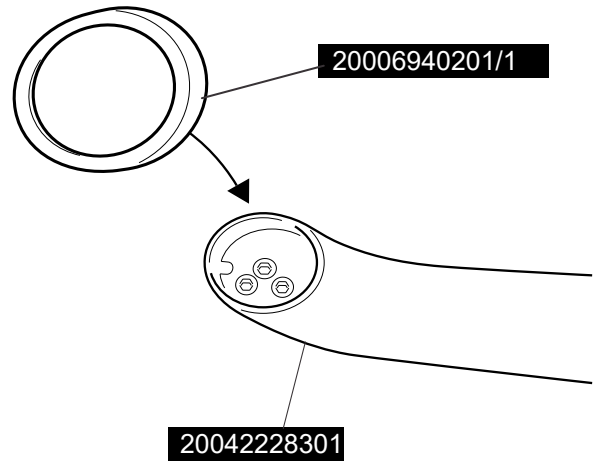

Repeat above steps to the other side using part number 20007045301 & 20006940201/1 .

1. Align part number 20040937701 (mounting bracket (R)) as indicated.
2. Fasten in to position using M8 x 25mm hex bolt, M8 spring washer and M8 flat washer.

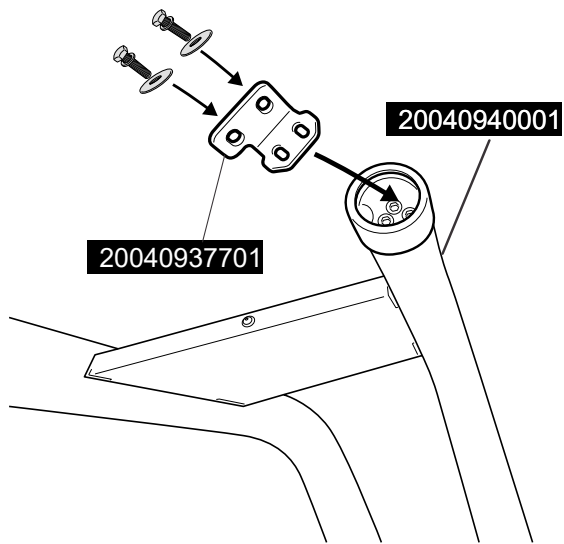

1. Align part number 20040937601 (mounting bracket (L)) as indicated.
2. Fasten in to position using M8 x 25mm hex bolt, M8 spring washer and M8 flat washer.

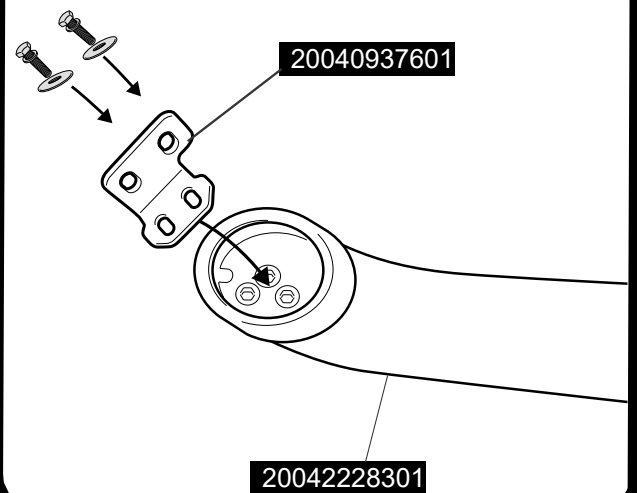

Repeat above steps to the other side.

Place Armour bar on the tub rail.

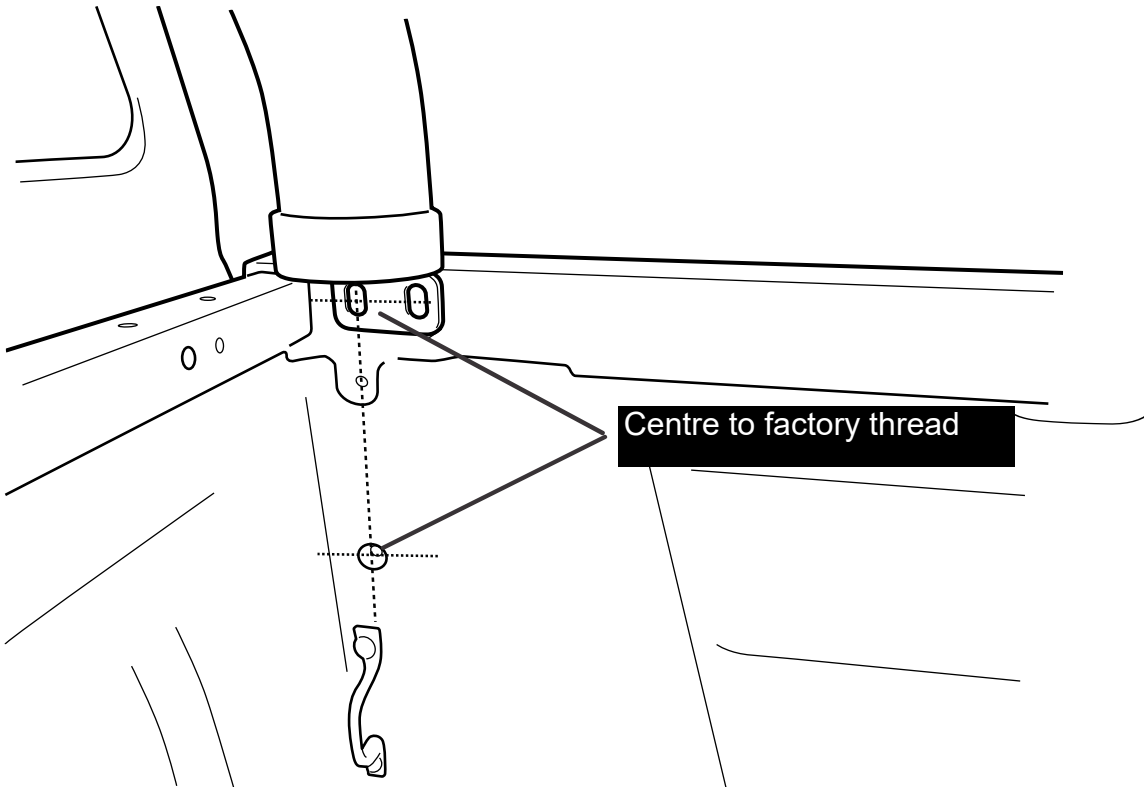
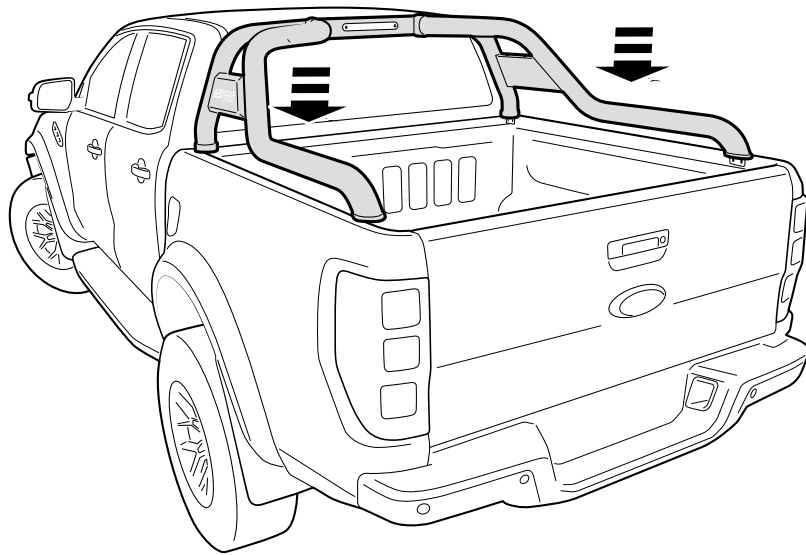

Repeat above steps to the other side.

Mark all points as indicated.

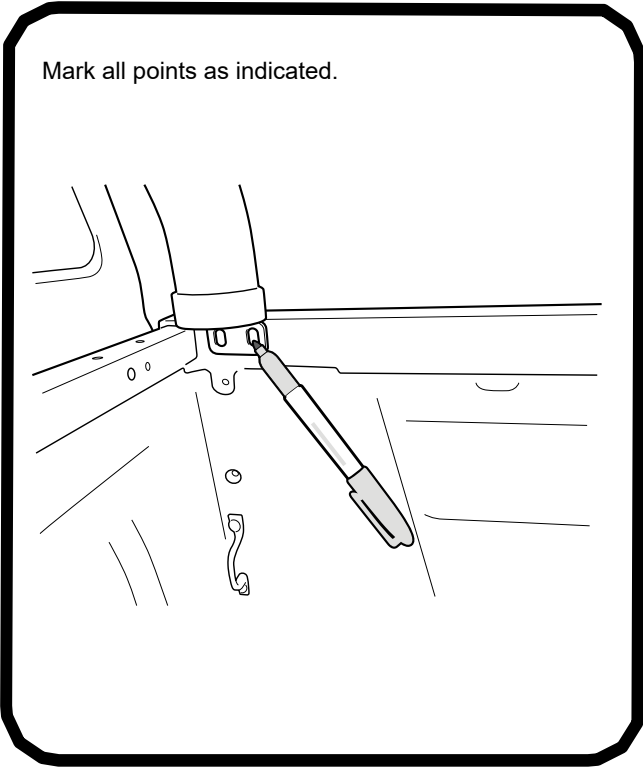

Mark all points as indicated.

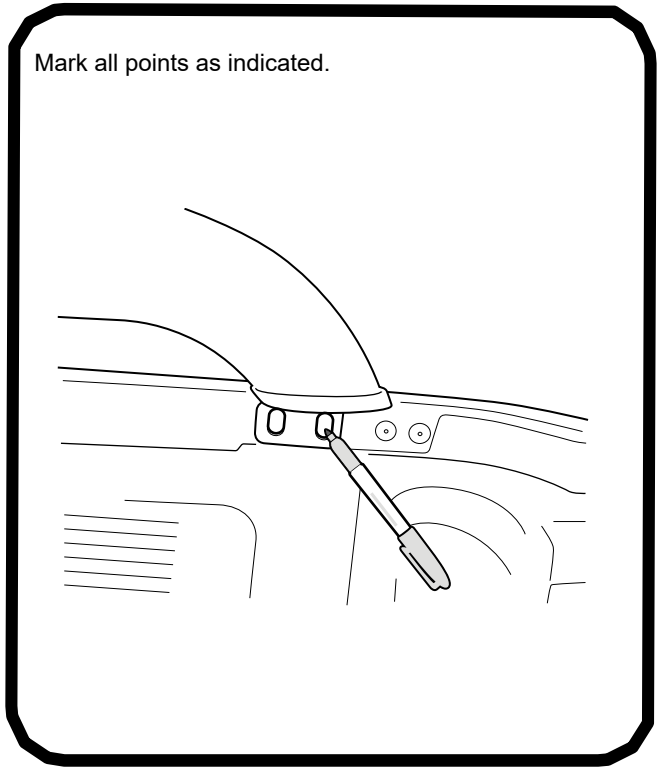

Repeat above steps to the other side.

Drill all marked locations to 8.5mm.

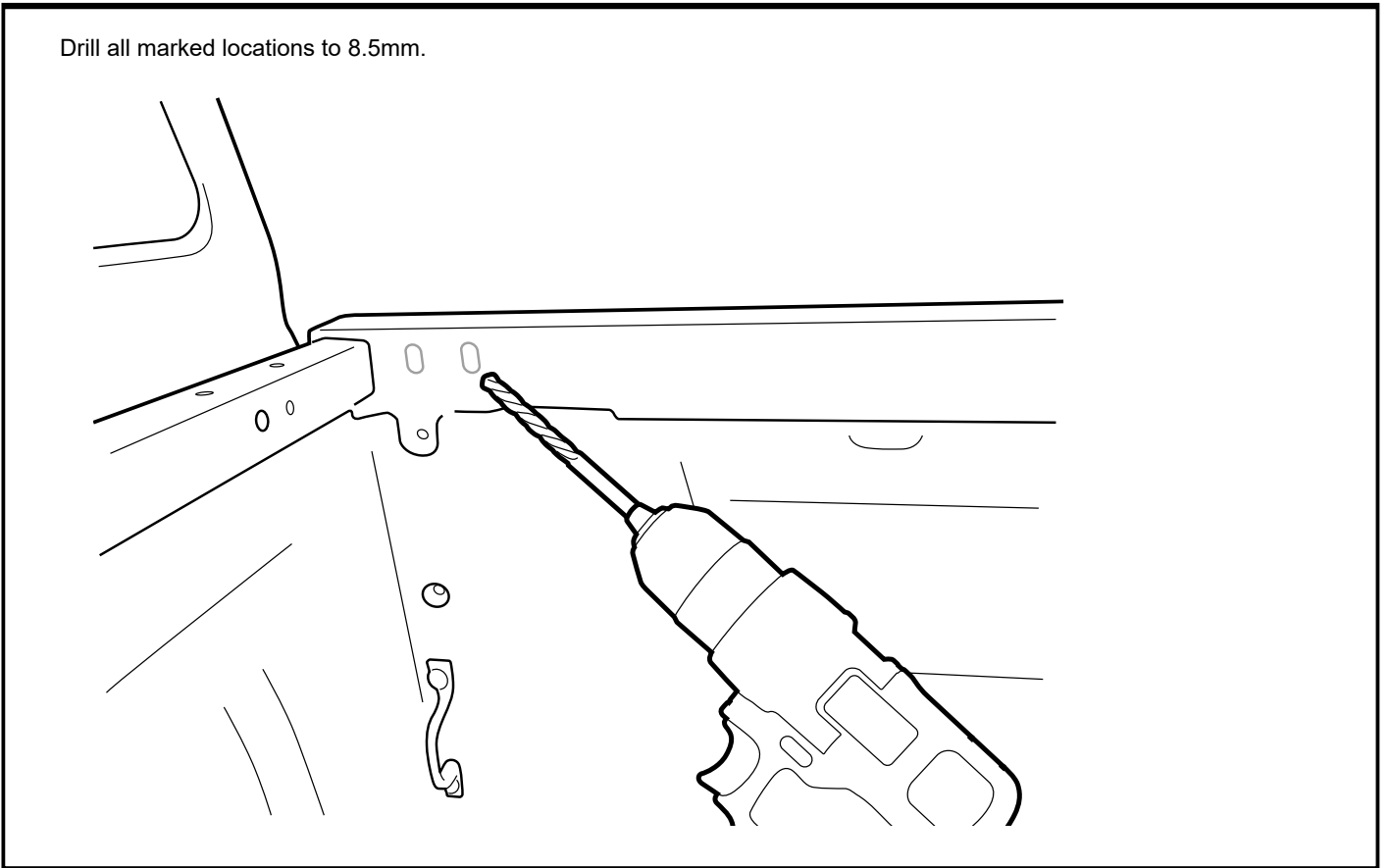

Feed M8 hex flange nut into the tub rail cavity behind the sports bar bracket hole.

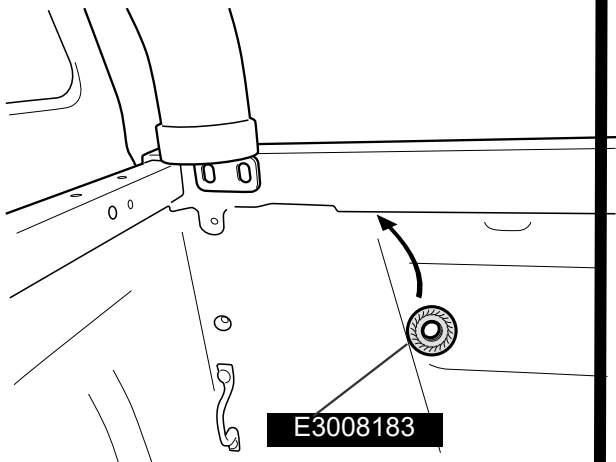

Fasten into place by using M8 hex flange bolt.

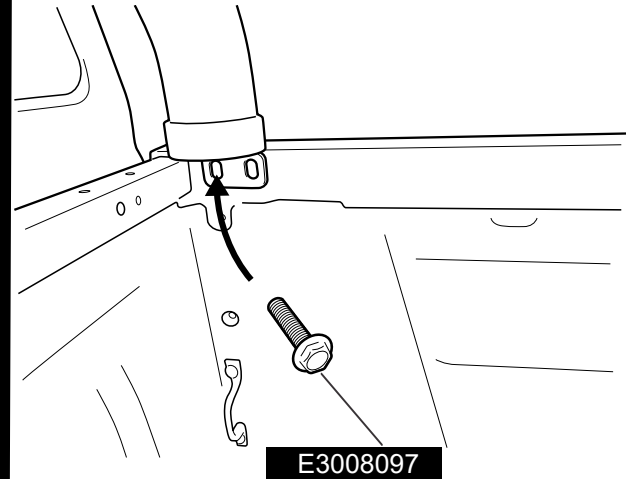

1. Remove passenger side tail light.
2. Route Armour bar wiring from front leg of tube towards passenger side taillight.

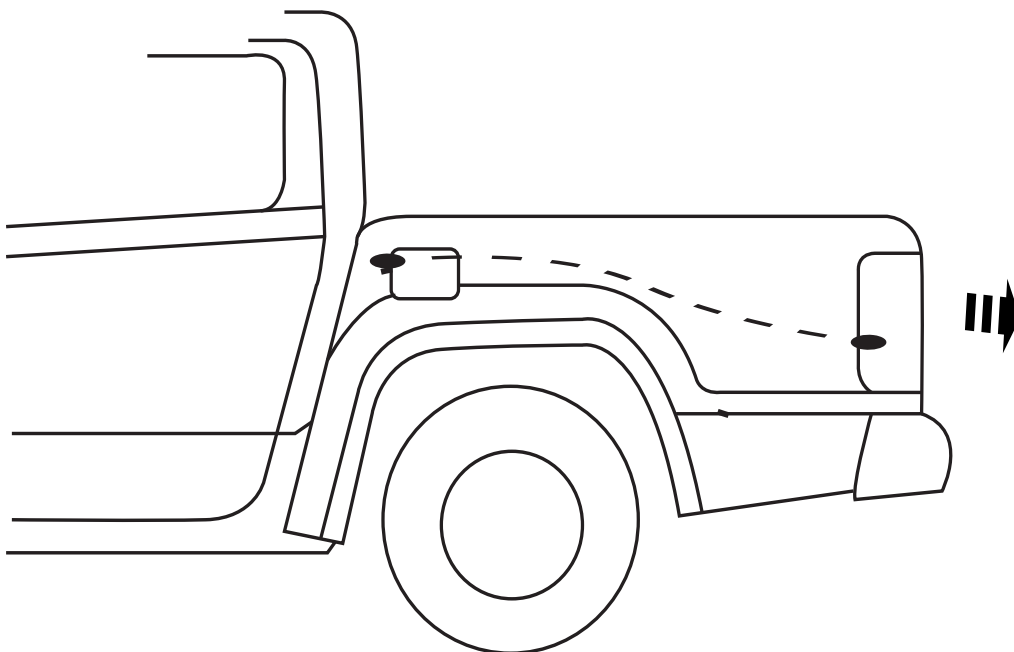

1. Locate vehicle brake light signals with a test light.
2. Attach scotch clamps provided to brake light signal wires.
3. Crimp accordingly.
4. Plug female connectors to male scotch clamp.

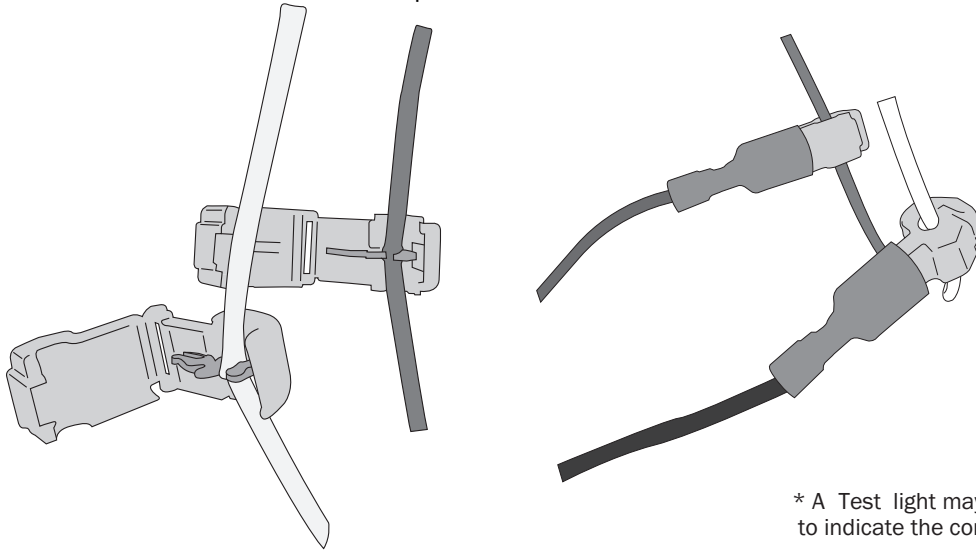

* A Test light may be needed to indicate the correct wires.

Connect Armour bar plug to patch plug connected to brake light signal Wires.

