



WWW.HSPUTELIDS.COM

1300 441 498

Part No: NP18 Fitting

Time: 45mins



NISSAN NP300 D23

HSP TAIL LOCK

FITTING INSTRUCTIONS

—General Notes

- Read through the fitting instructions prior to installation of accessory.
- Ensure all Recyclable components, packaging are discarded & recycled following local recycling regulations.
- Safely store and protect and removed vehicle components.

—Safety Notes

- Check that all work practices comply with safety standards.
- Please wear appropriate clothing and use safety equipment.

- WARNING Failure to install product not in accordance with manufacturers instructions may result in fire.

- WARNING Failure to install product not in accordance with manufacturers instructions may void warranty.
- WARNING We recommend disconnecting the battery terminals before commencing install of tail lock. Please ensure you have your vehicle book with radio/infotainment codes on the unlikely chance these need to be re-entered in.

—Fitting Time



45mins

—PARTS SUPPLIED

Part Description	Part Number	Quality/ Length	CHECK LIST
TAIL LOCK ASSEMBLY			
Main Bracket	NP18-A	1	
Rod	NP18-B	1	
Lever	NP18-C	1	
Actuator	ACT-01	1	
Wiring	CL-LOOM-LONG	1	
Patch Wiring	NP-PATCH	1	
FASTENERS			
Actuator Screws	36	2	
OTHER			
Cable Ties		5	
Rod Clips	37	2	
Fitting Instruction		1	

—STEP 1

Fit rod into actuator as shown.

1. Push Plastic striker on to the actuator till it clicks into position.
2. Load Rod into the actuator striker as shown.

ACT-01

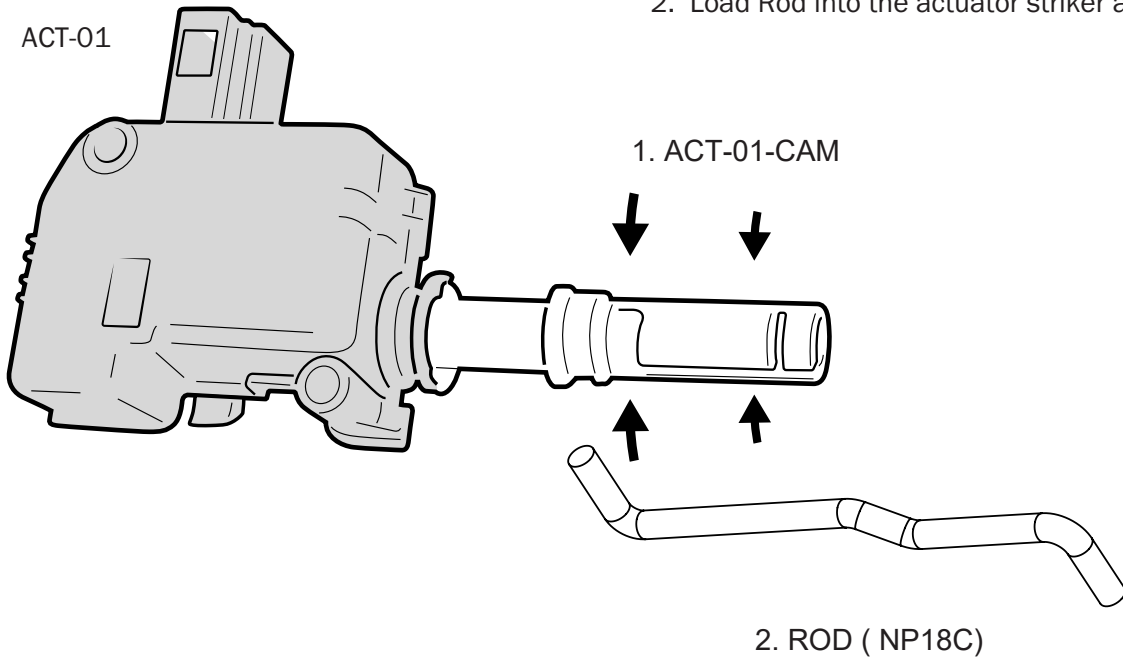

STEP 2

Fit actuator to TailLock bracket as shown.

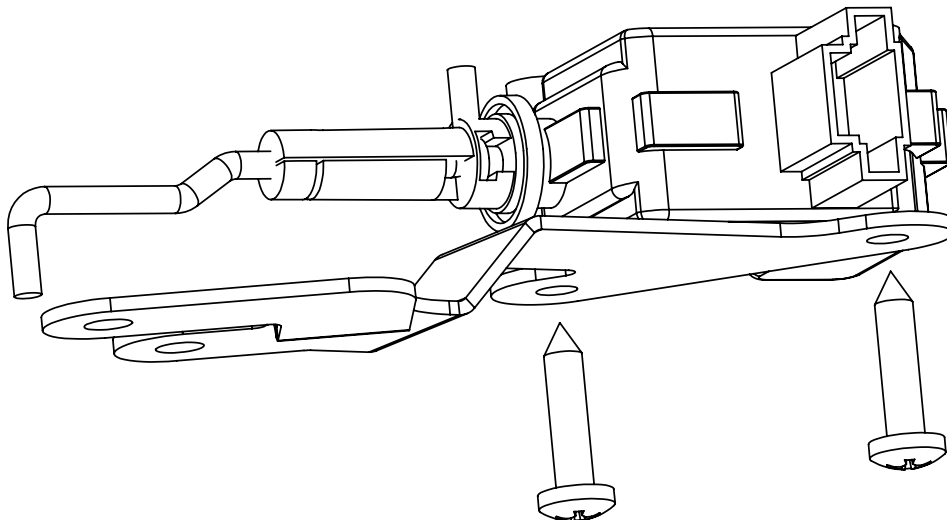

— STEP 3 —

Fit the rod clips into NP18b as per image.

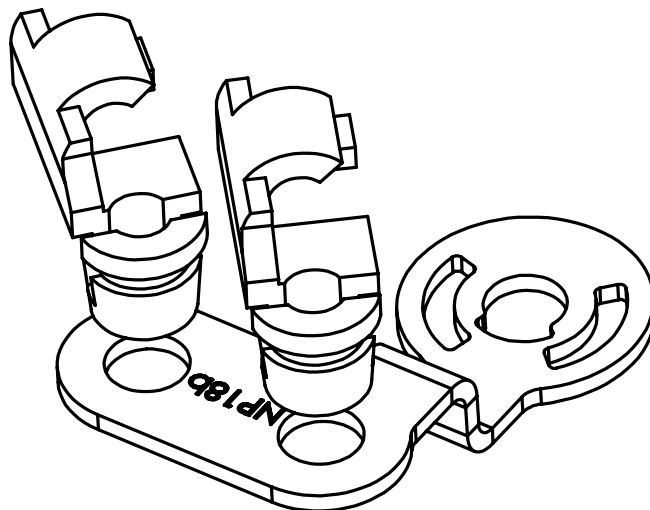

— STEP 4 —

Remove tail gate cover.

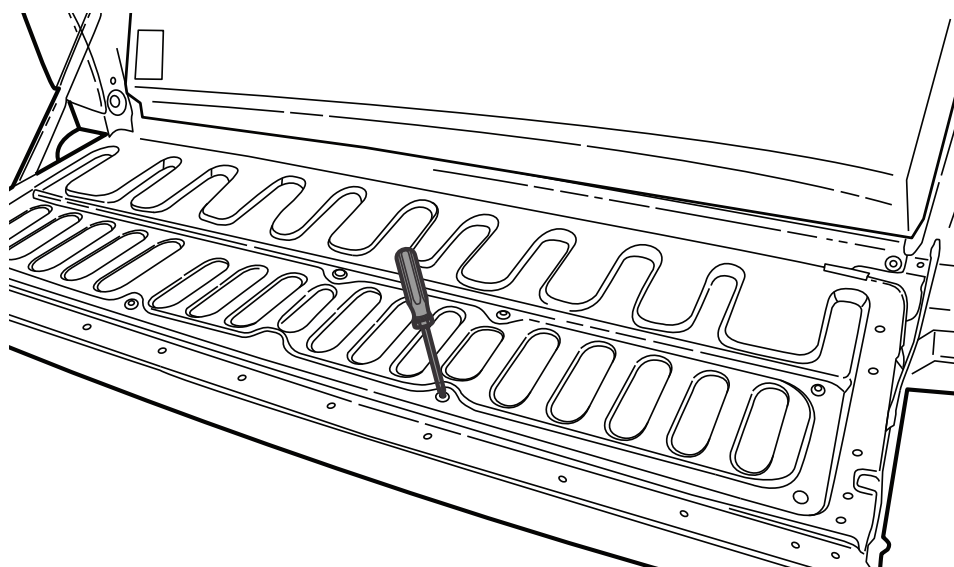

— STEP 5 —

Standard assembly.

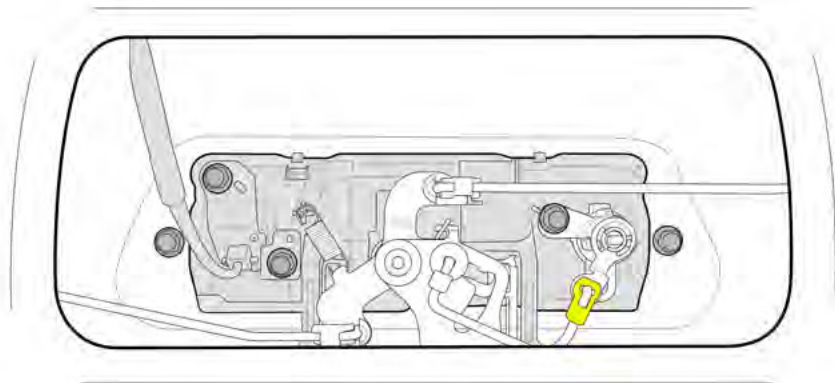

— STEP 6 —

Remove rod as shown.

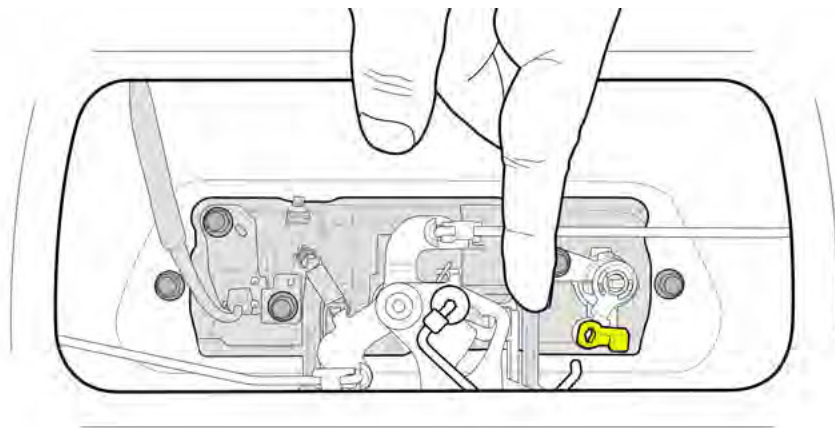

— STEP 7 —

Remove the cam as shown and by carefully removing the cert clip.

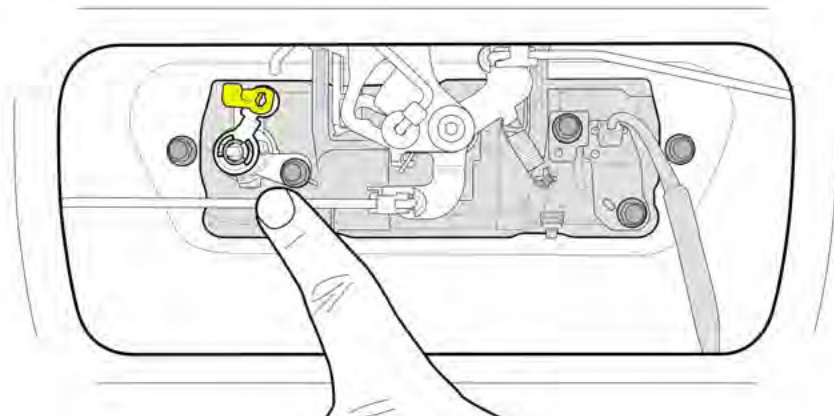

— STEP 8 —

Fasten the 2 bolts shown.

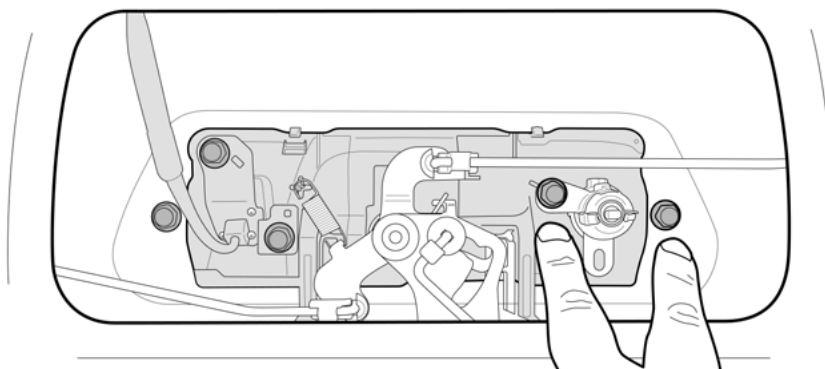

— STEP 9 —

Install TailLock assembly as shown. Use cert clip removed from original cam to secure the new cam in place. Plug actuator rod as shown.

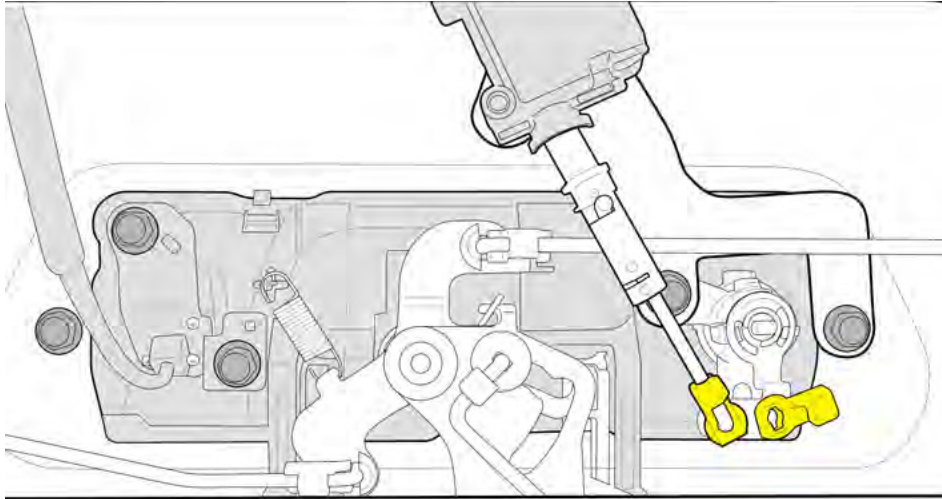

— STEP 10 —

Attach rod to the new cam as shown.

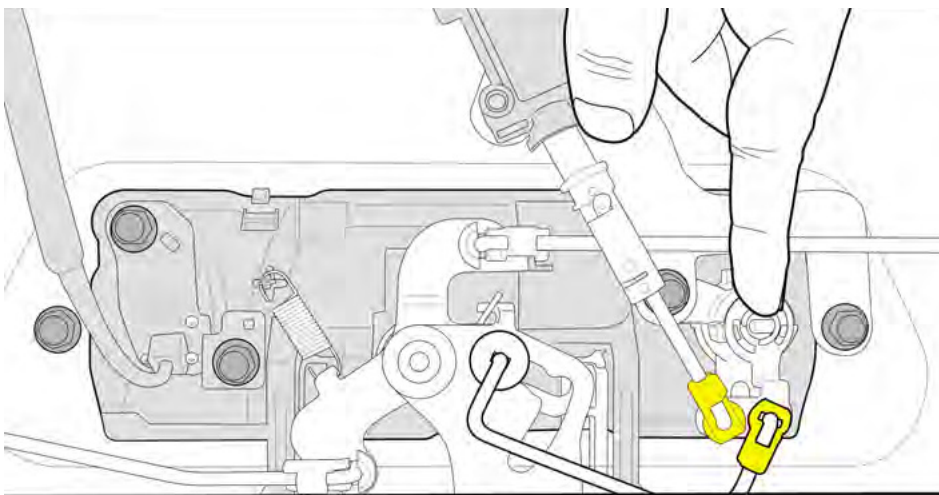

— STEP 11 —

Plug wiring to the actuator end.

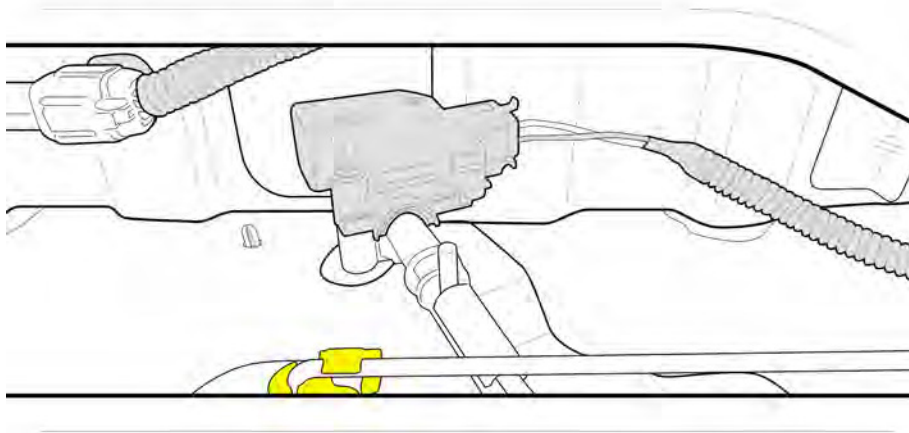

— STEP 12 —

Run wiring as shown over the passenger side chassis rail. Be sure to use cable ties provided every 400mm.

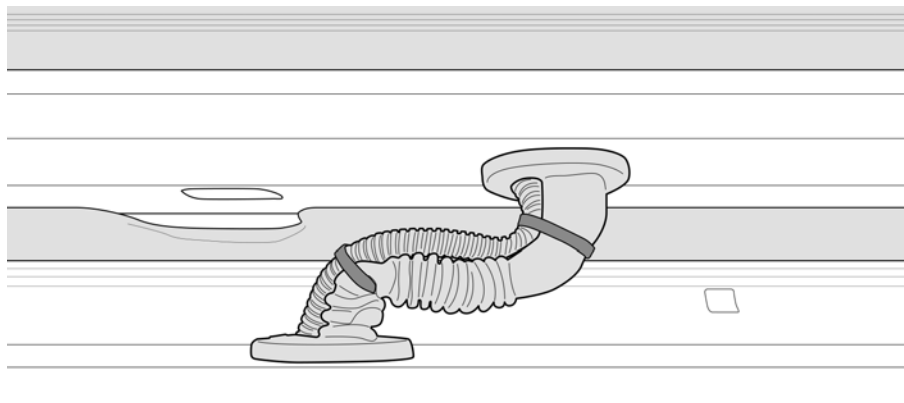

— STEP 13 —

Make a small hole under the front passenger side rail. Be sure to check for obstructions on both sides. Run wiring through small hole made.



NOTE: To avoid drilling you can also run the loom through the grommets of the firewall into the kick panel. Seal accordingly.

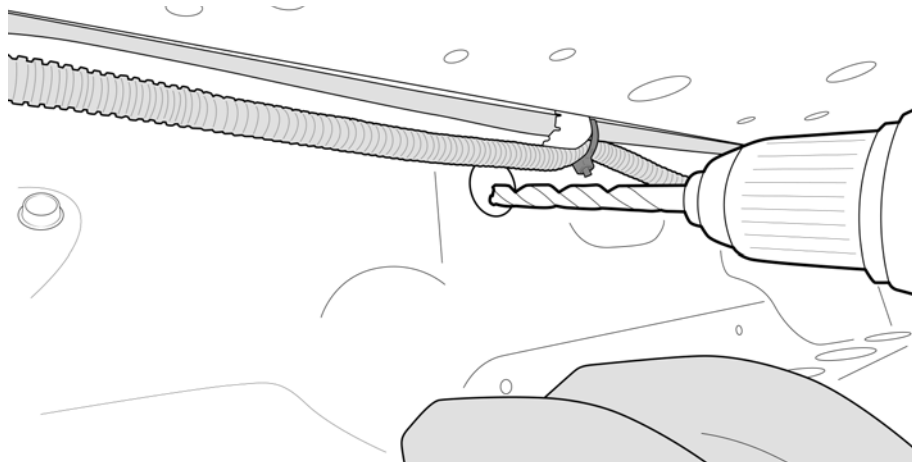

— STEP 14 —

Remove scuff plate.

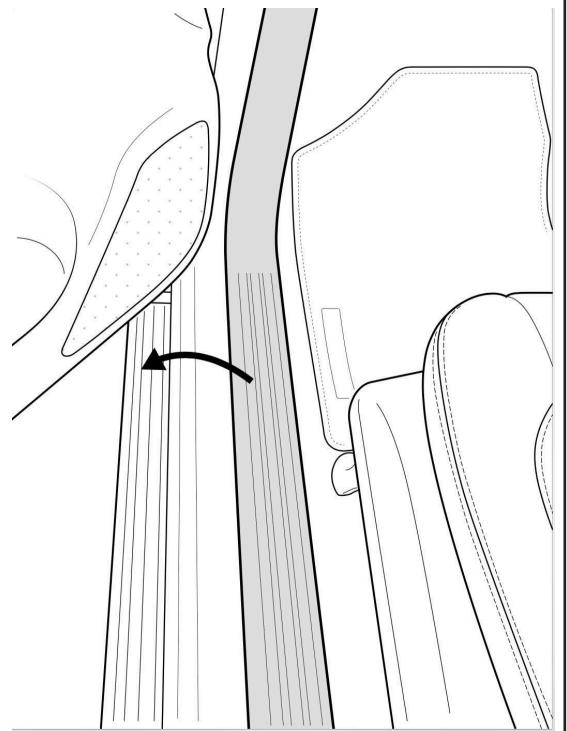

— STEP 15 —

Remove kicker panel.

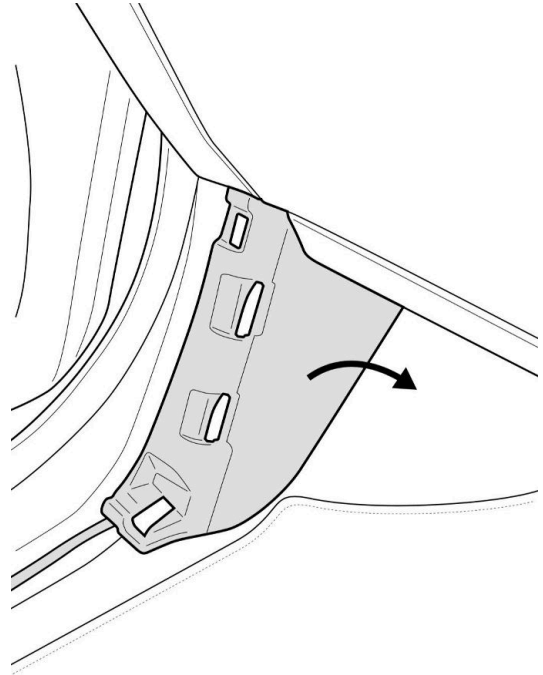

— STEP 16 —

Unplug indicated wiring and plug NP-PATCH wiring.

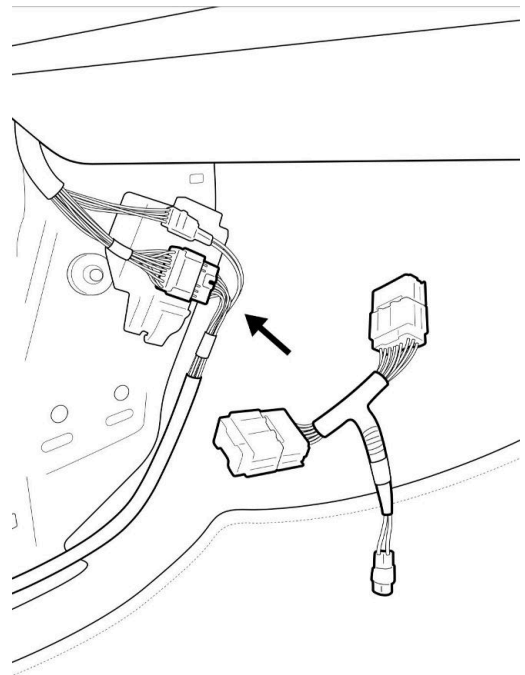

— STEP 17 —

Plug CL-LOOM-LONG to PATCH wiring.

Cable tie overhang of wires and assemble all panels removed earlier.

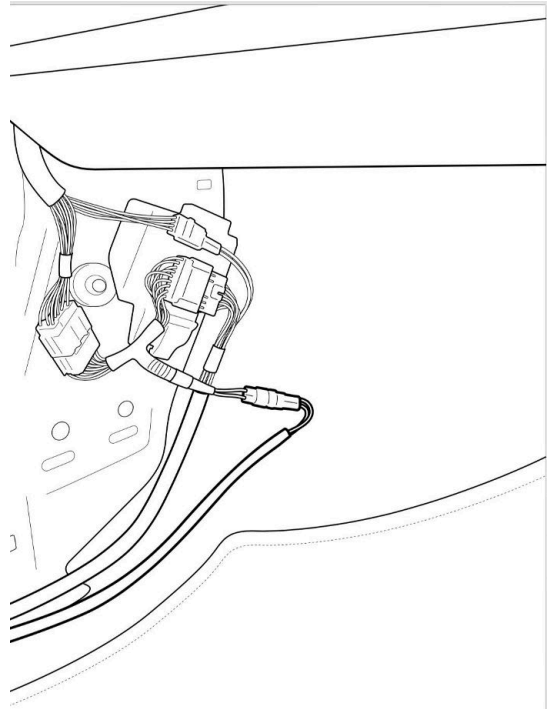

— STEP 19 —

Seal any area where there was an incision or a hole made to have the loom feed in to the cab.

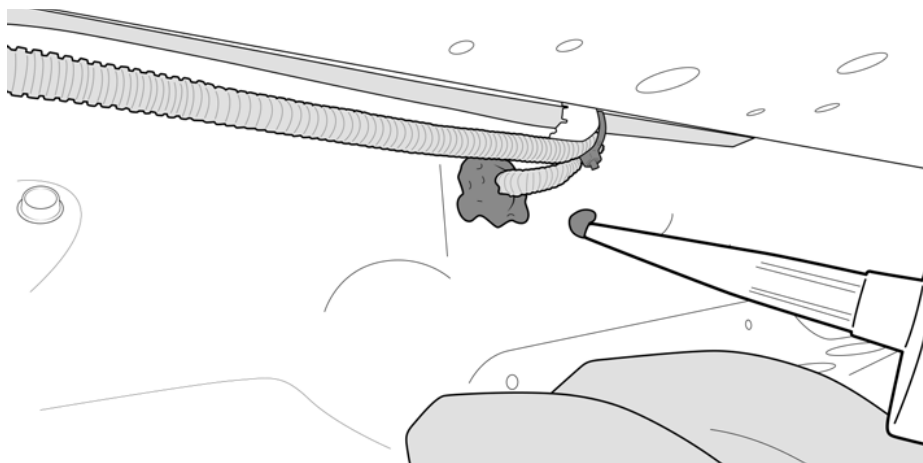

— FITTING COMPLETE —
