



WWW.HSPUTELIDS.COM

1300 441 498

Part No: NN18

Fitting Time: 45mins



NISSAN NP300 D23 MY21+

HSP TAIL LOCK

FITTING INSTRUCTIONS

—GENERAL NOTES

- Read through the fitting instructions prior to installation of accessory.
- Ensure all recyclable components and packaging are discarded and recycled following local recycling regulations.
- Safely store and protect any removed vehicle components.

—SAFETY NOTES

- Check that all work practices comply with safety standards.
- Please wear appropriate clothing and use safety equipment.

—FITTING TIME



45mins

—PARTS SUPPLIED

Part Description	Part Number	Quantity	CHECK LIST
TAIL LOCK ASSEMBLY			
Main Bracket	NP18-A	1	
Rod	NP18-B	1	
Lever	NP18-C	1	
Actuator	ACT-01	1	
Wiring	CL-LOOM-SHORT	1	
Patch Wiring	NN-PATCH	1	
FASTENERS			
Actuator Screws	36	2	
OTHER			
Cable Ties		5	
Rod Clip	37	1	
Fitting Instructions		1	

— STEP 1 —

Fit rod into actuator as shown.

1. Push Plastic striker on to the actuator till it clicks into position.
2. Load Rod into the actuator striker as shown.

ACT-01

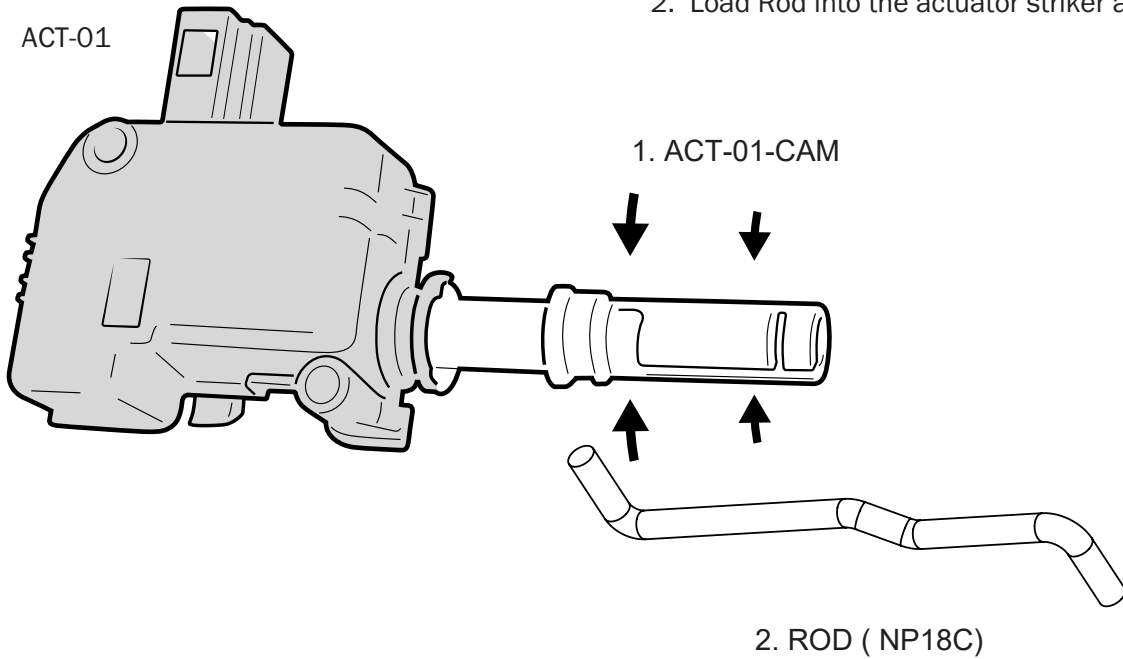

STEP 2

Using actuator screws (36) fit actuator to TailLock bracket (NP18-A) as shown.

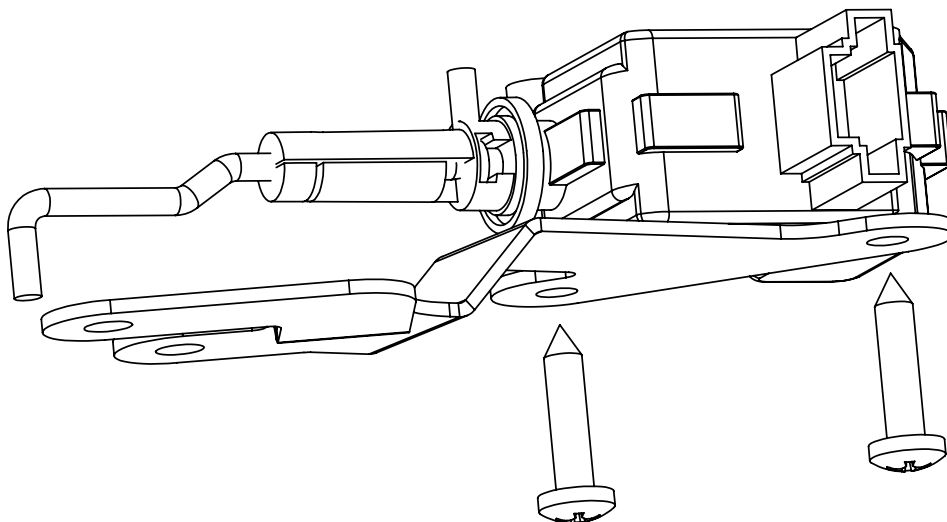

— STEP 3 —

Remove tail gate cover.

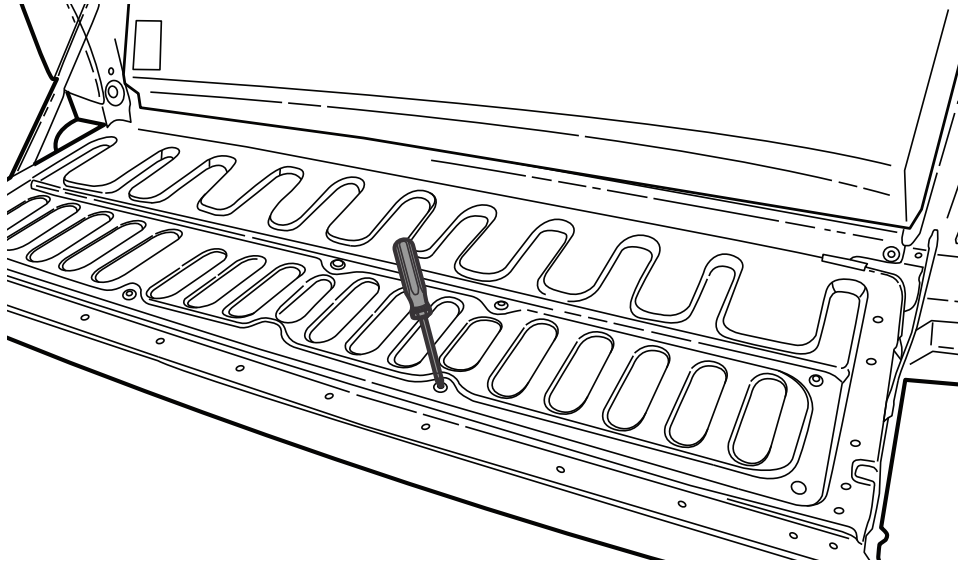

— STEP 4 —

Standard assembly.

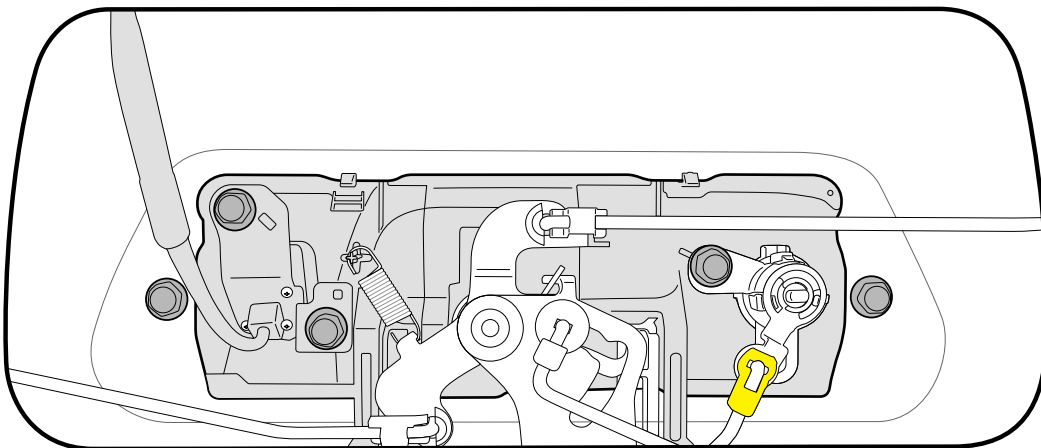

— STEP 5 —

1. Un-clip rod as shown.
2. Remove and retain rod clip.

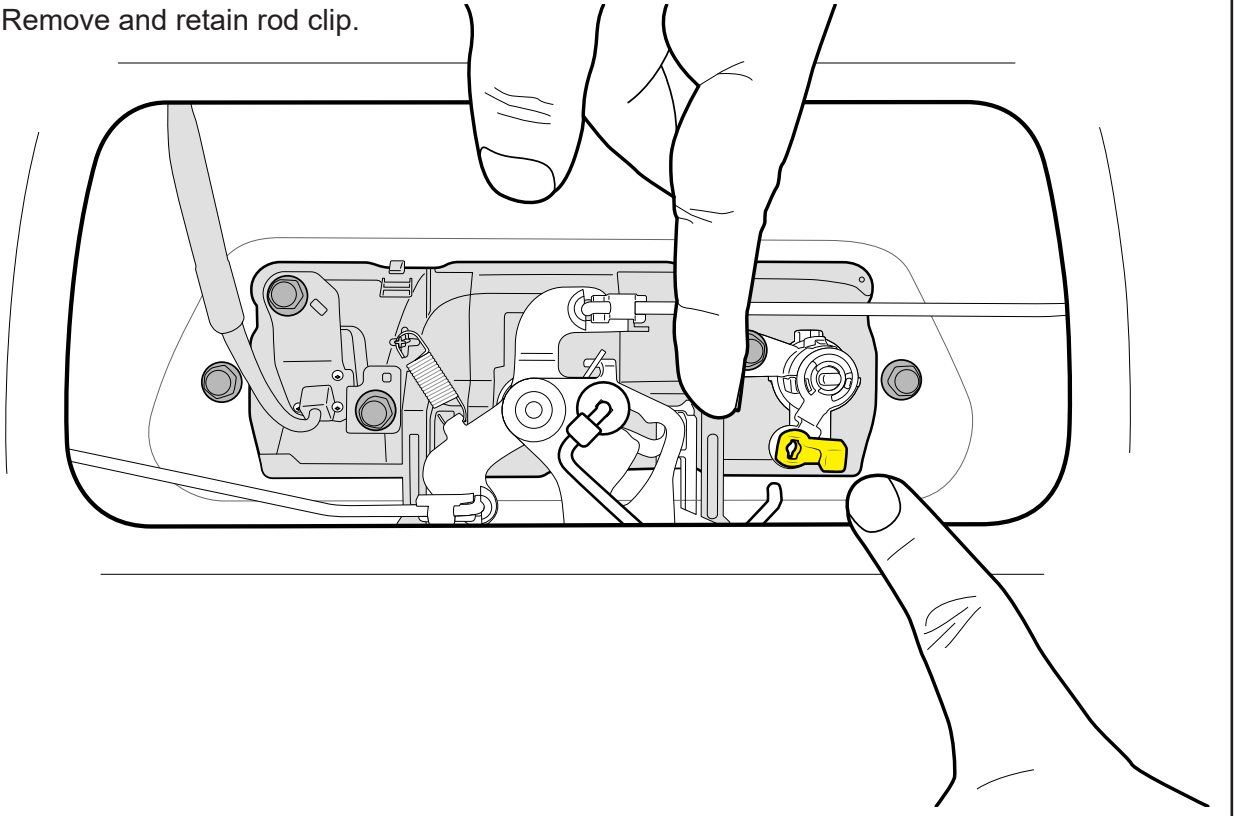

— STEP 6 —

With care remove cert clip and retain, remove the cam and discard.

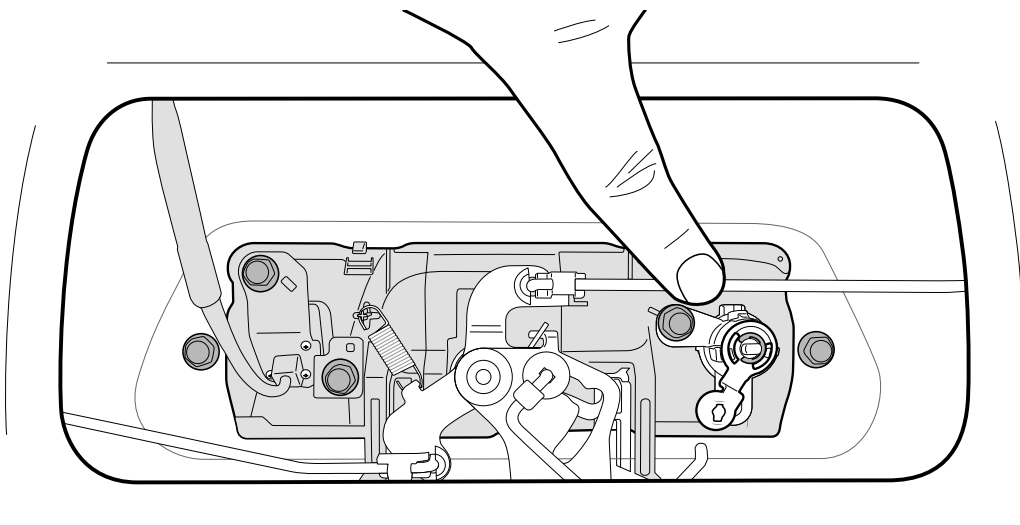

— STEP 7 —

Unfasten the 2 bolts shown and retain.

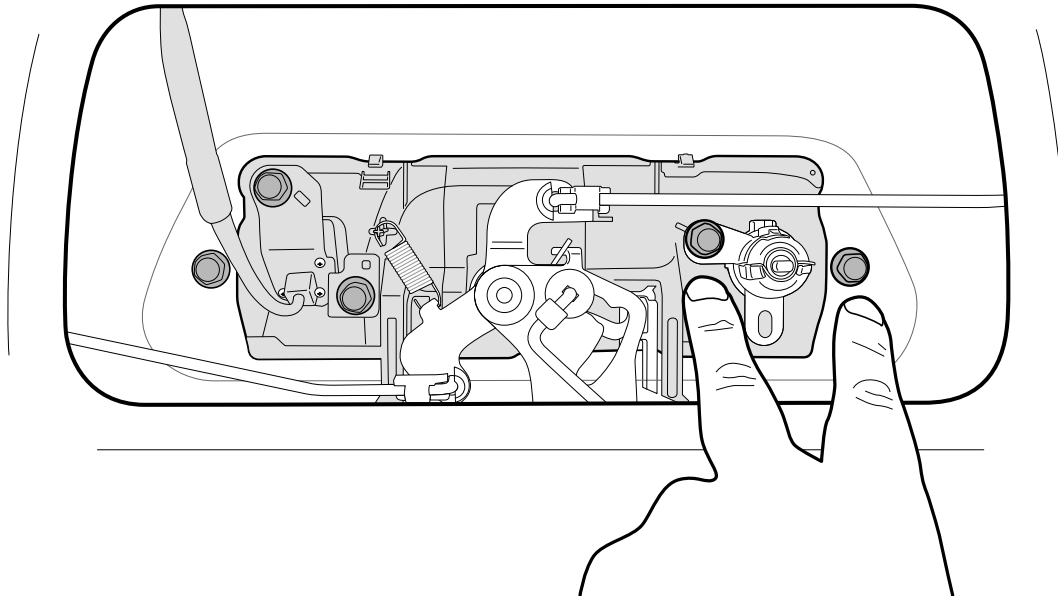

— STEP 8 —

Fit retained and supplied rod clips to indicated location in to bracket NP18B.

Factory retained rod clip.

Supplied rod clip (37)

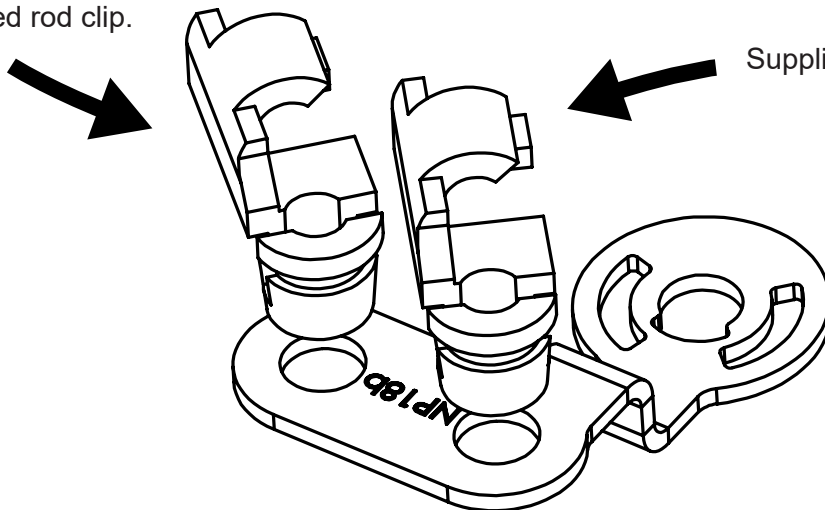

— STEP 9 —

Install TailLock assembly as shown (fasten using retained factory bolts, **set to 8Nm torque**) Use retained cert clip removed from original cam to secure the new cam in place. Plug actuator rod as shown.

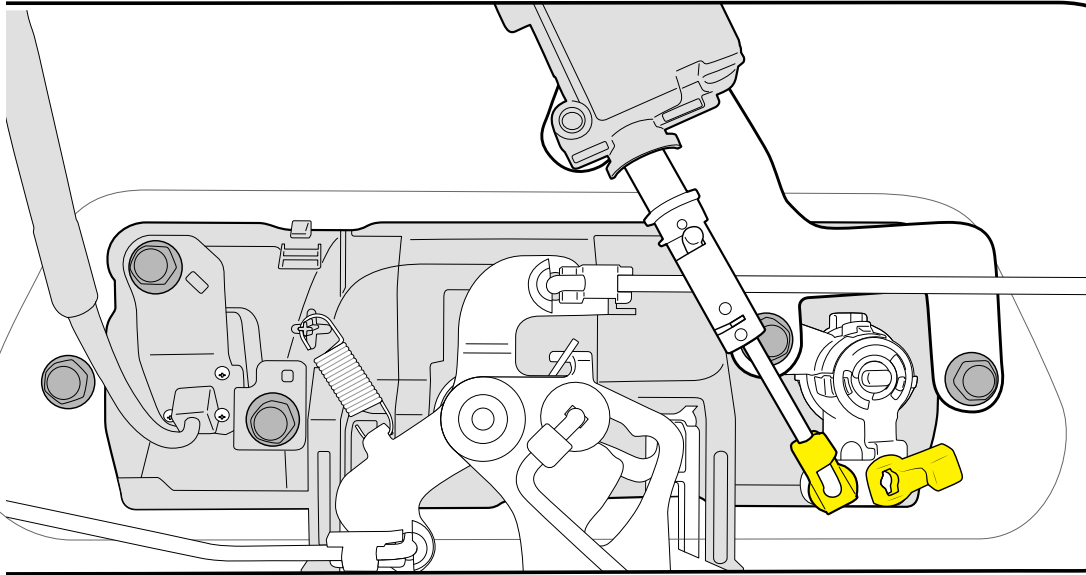

— STEP 10 —

Attach rod to the new cam as shown.

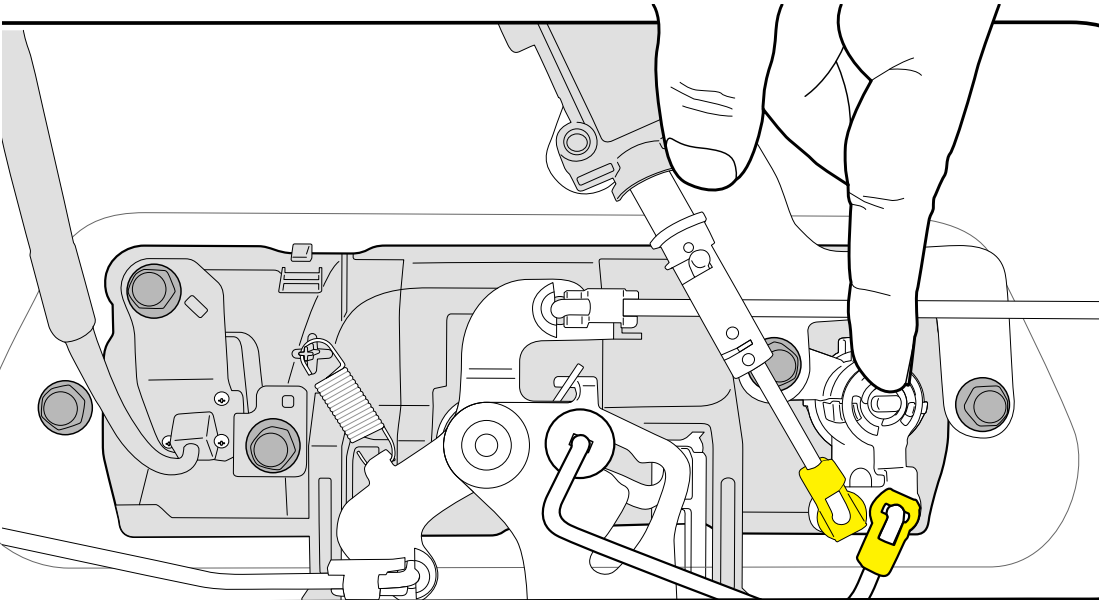

— STEP 11 —

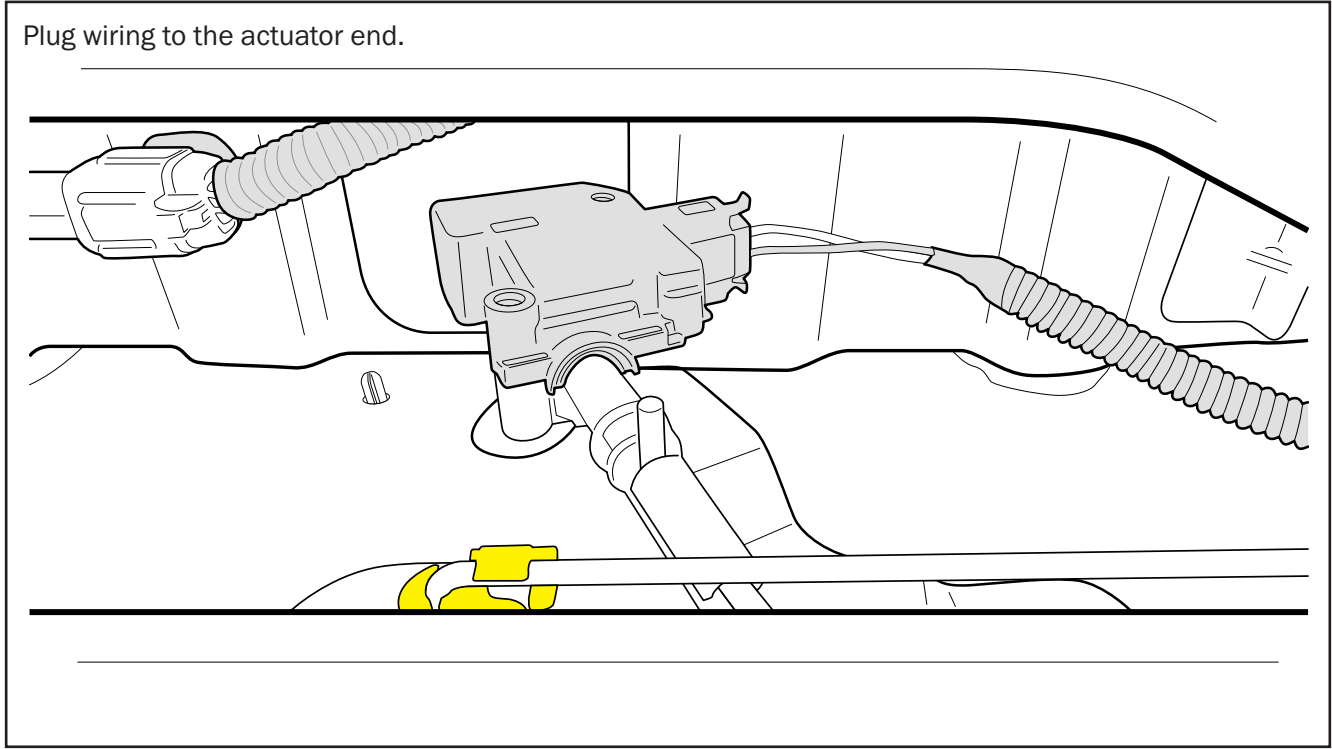

— STEP 12 —

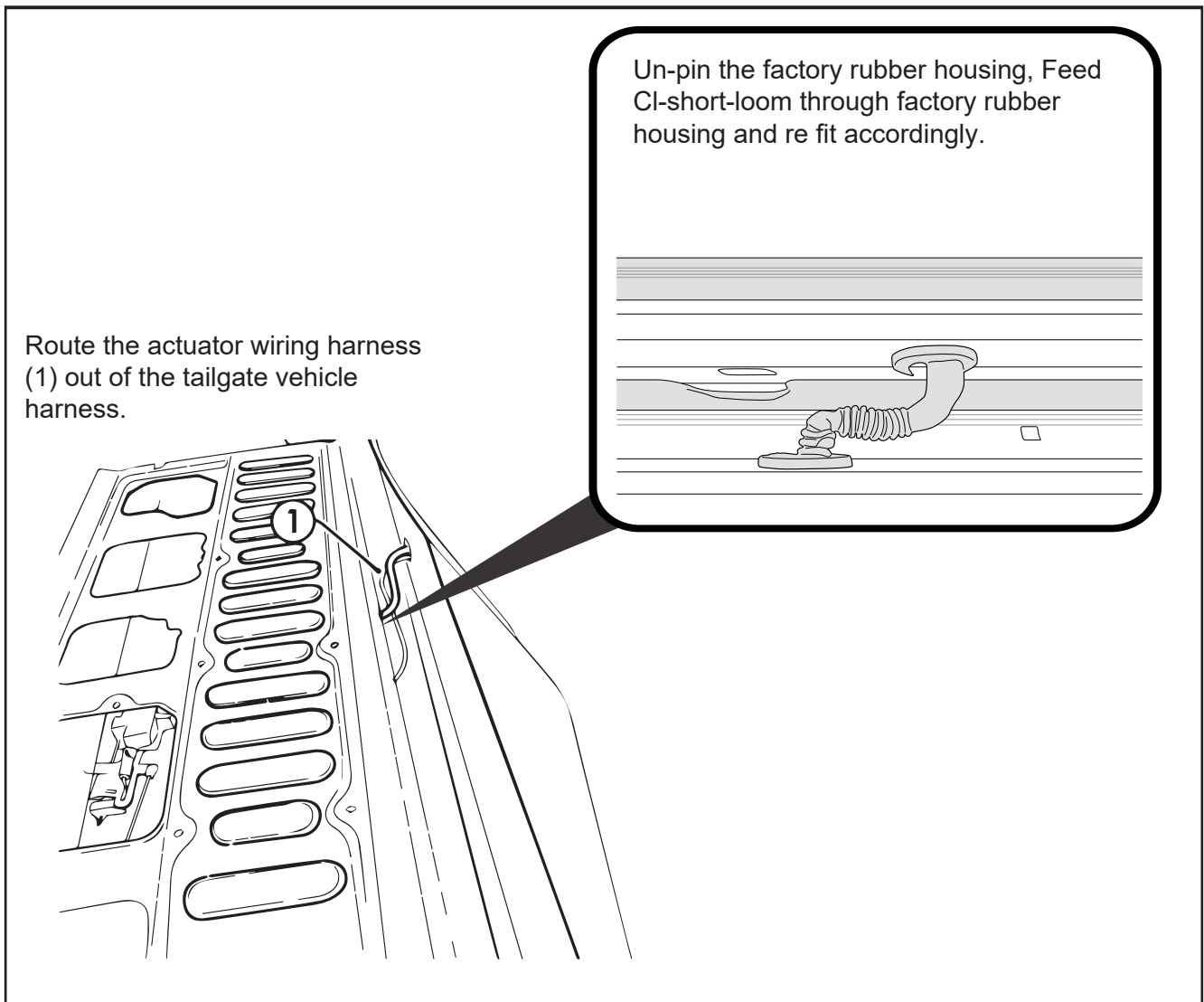

— STEP 13 —

Run wiring from tailgate to fuel cap. Use cable ties every 400mm.

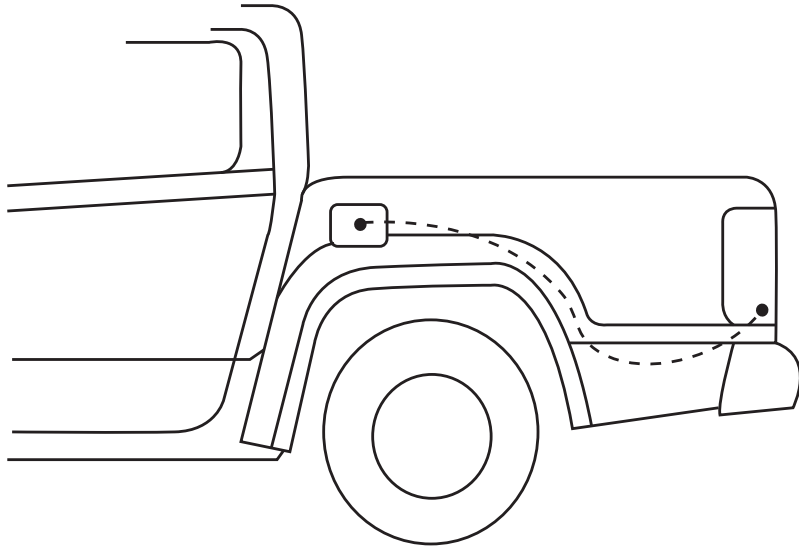

— STEP 14 —

Remove indicated fuel cap wiring cover.

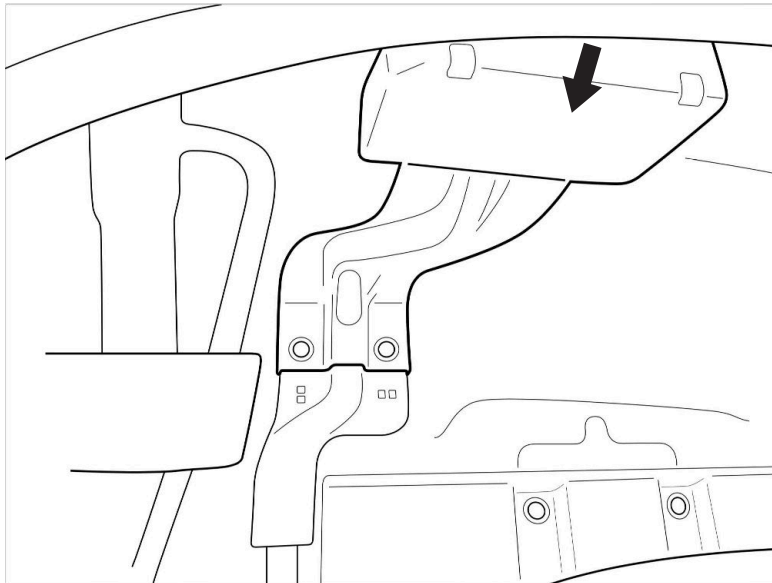

— STEP 15 —

Unplug fuel cap wiring.

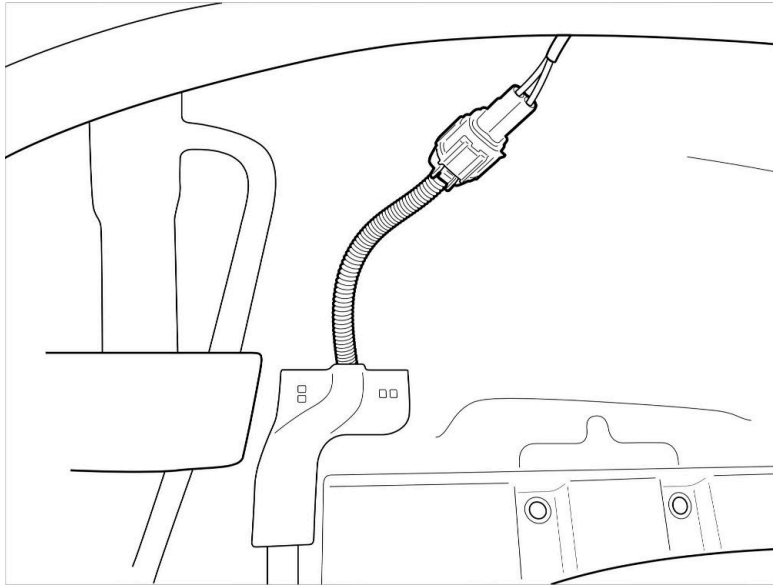

— STEP 16 —

- 1) Plug NN-PATCH wiring.
- 2) Plug CL-LOOM-SHORT wiring.

Cable tie overhang of wiring and place the cover removed earlier.

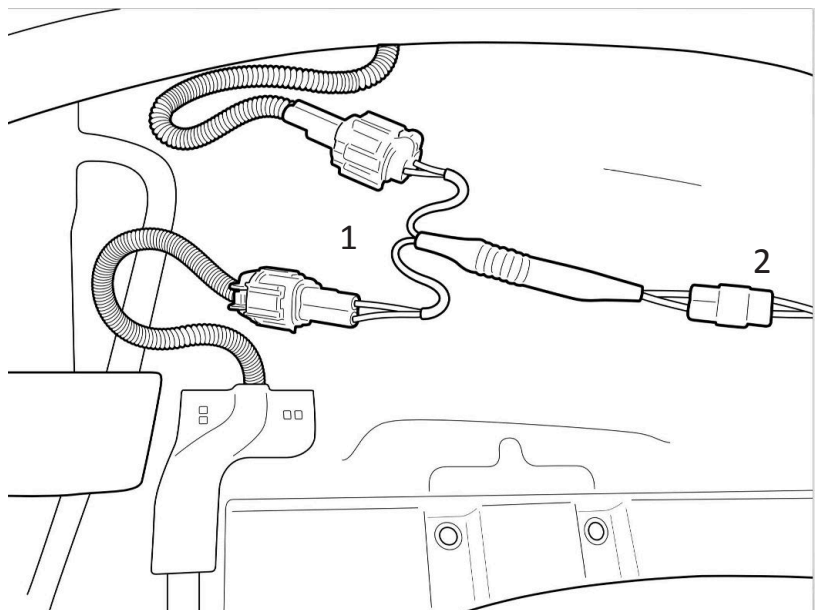

Re-fit fuel cap wiring cover.

STEP 17

Re-fasten the tailgate cover.

