



www.Hsputelids.com

1300 441 498

Part No: NGR18

Fitting Time: 45mins



**New Gen Ford Ranger XL MY22.5
Fitted with tailgate lock barrel**

HSP TAIL LOCK

FITTING INSTRUCTIONS

—GENERAL NOTES

- Read through the fitting instructions prior to installation of accessory.
- Ensure all recyclable components and packaging are discarded and recycled following local recycling regulations.
- Safely store and protect any removed vehicle components.

—SAFETY NOTES









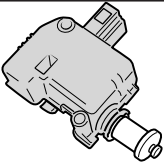
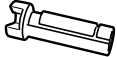
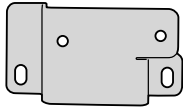

- Check that all work practices comply with safety standards.
- Please wear appropriate clothing and use safety equipment.

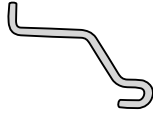
—FITTING TIME

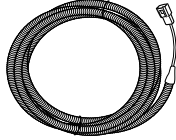

45mins

—PARTS SUPPLIED

 ACT-01	 ACT-01-C	 NGR18-A	 NGR18-B	 NGR18-C	 36 QTY - 2
 M5 x 25mm	 M5 NYLOC NUT	 CL-LOOM-SHORT	 NGR-PATCH	 CABLE TIE Qty x 16	 M5 WASHER

— Step 1 —

Fit the rod (NGR18-C) to plastic striker (ACT-01-C) as indicated. .

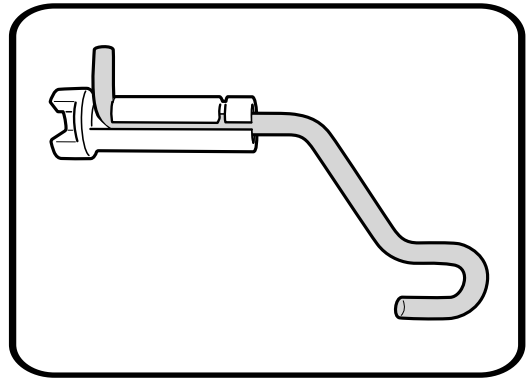
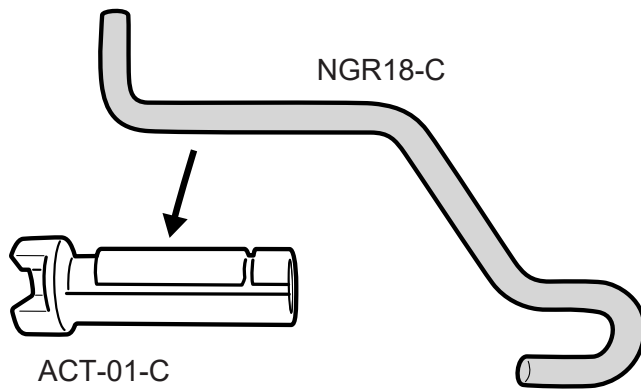

— Step 2 —

Align Actuator (ACT-01) to bracket NGR18-A as indicated.

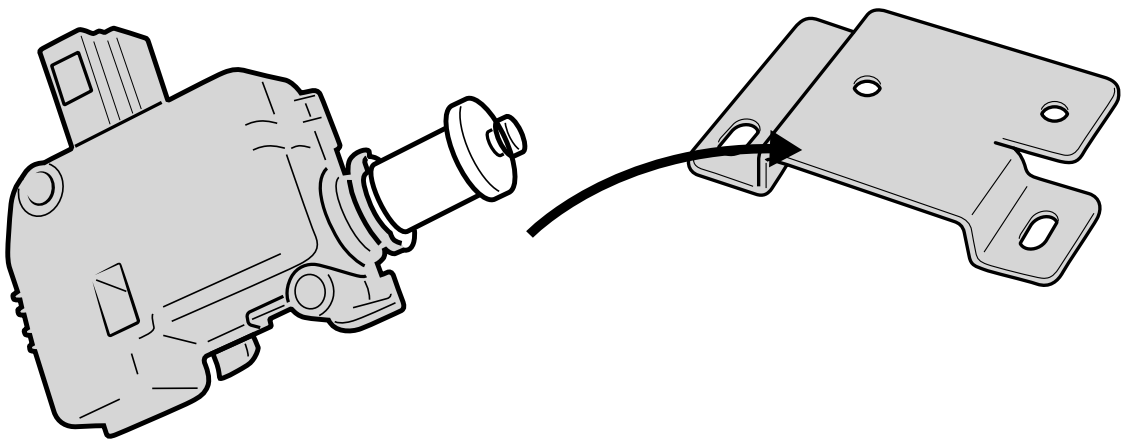

— Step 3 —

Using actuator screws (36) fasten bracket to actuator (ACT-01).

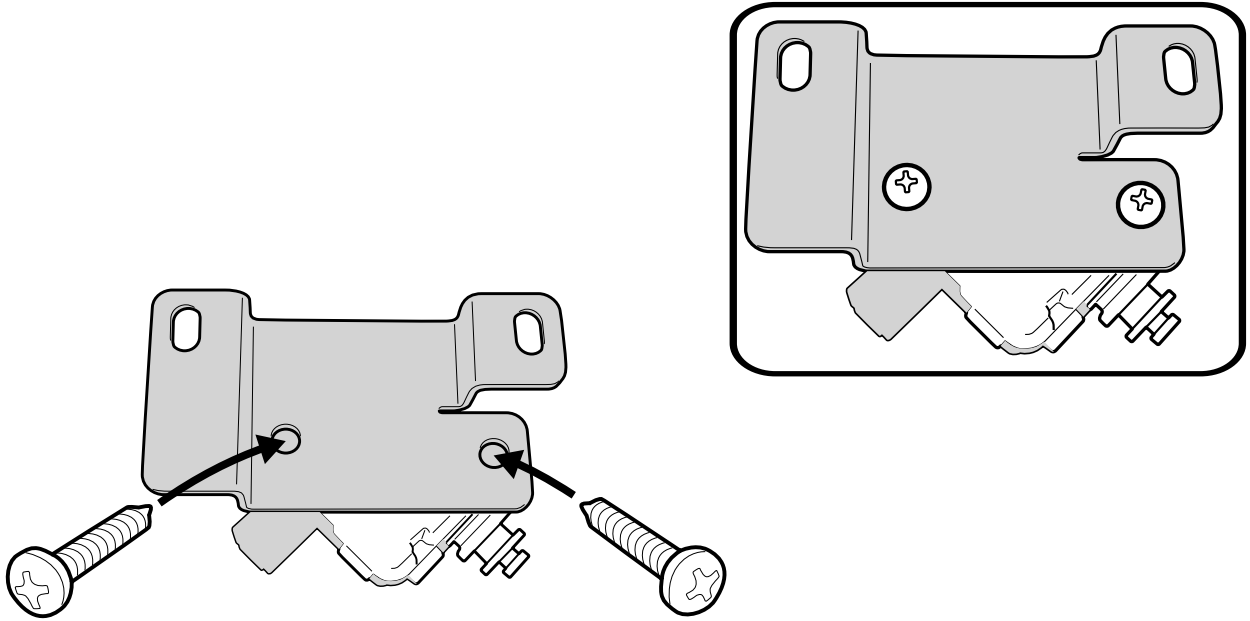

— Step 4 —

Remove tailgate access panel.

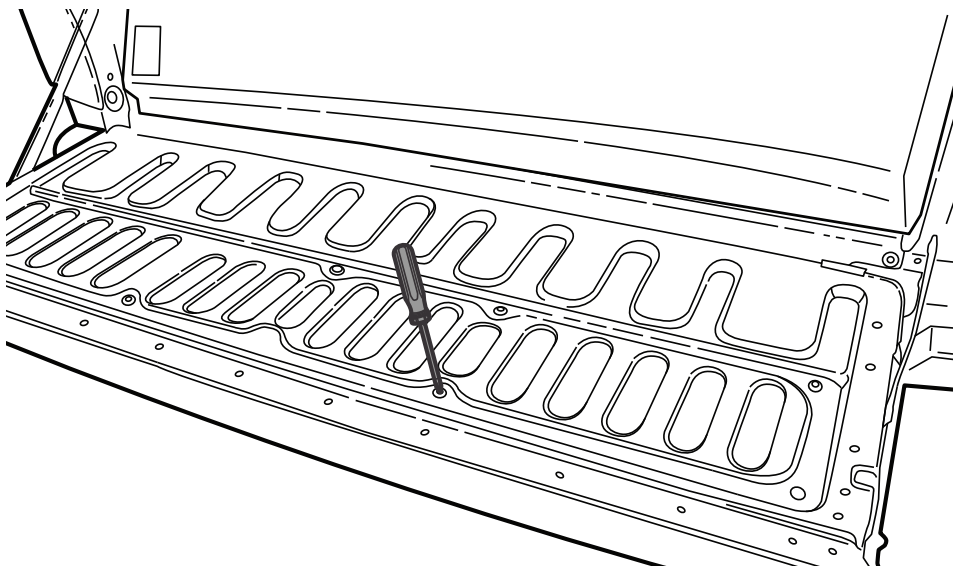

— Step 5 —

Disconnect the rods as indicated.

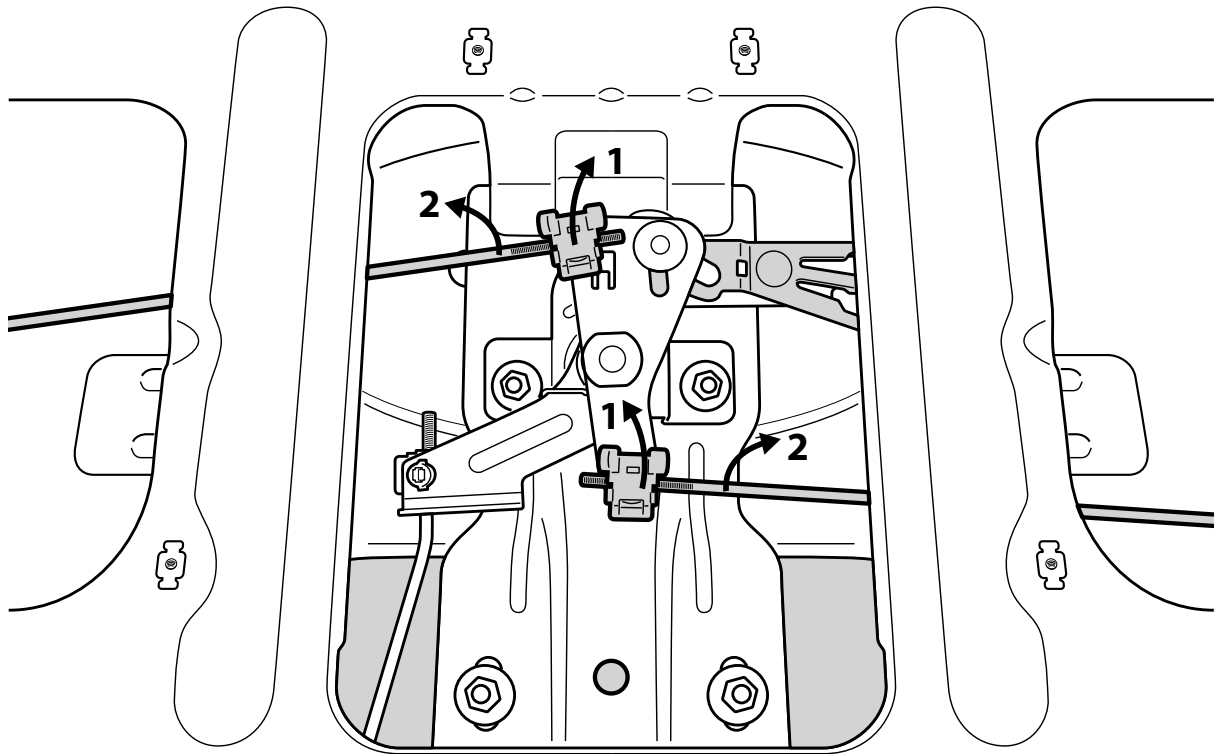

— Step 6 —

1. Unfasten the indicated bolts and retain hardware.
2. Remove indicated body clip and discard.

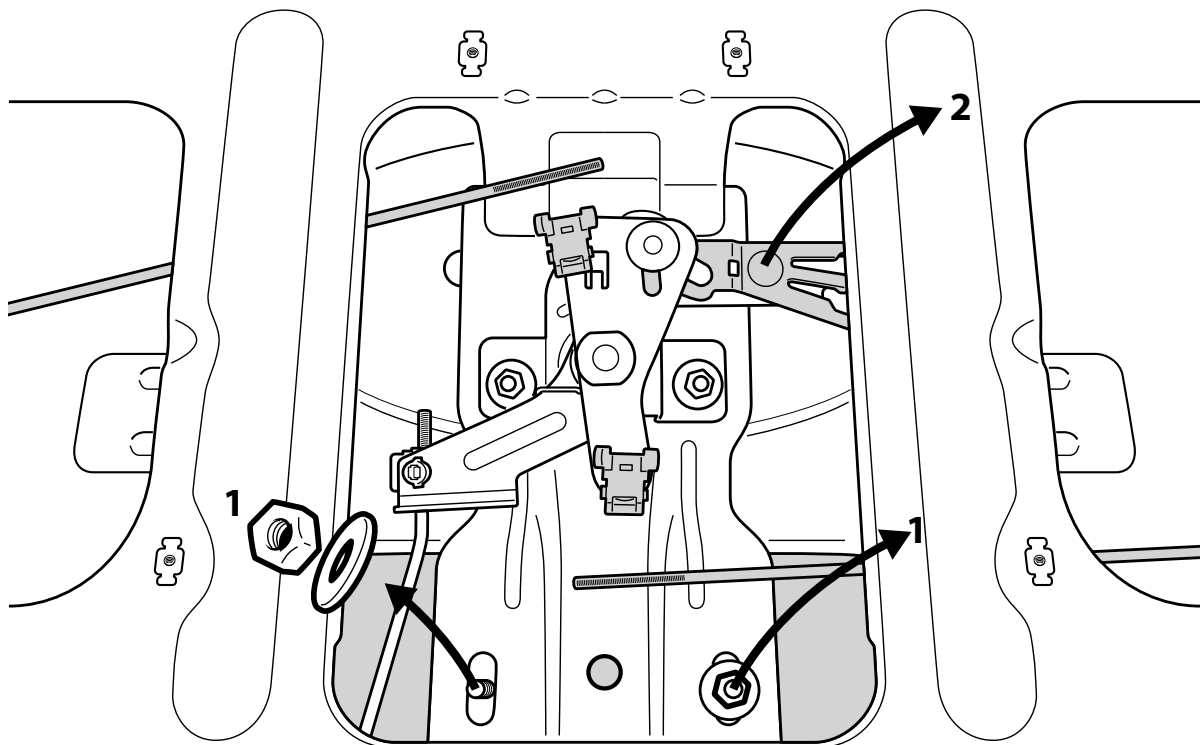

— Step 7 —

Place bracket (NGR18-B) over factory lever as indicated.
Align the bracket hole to the indicated lever hole.

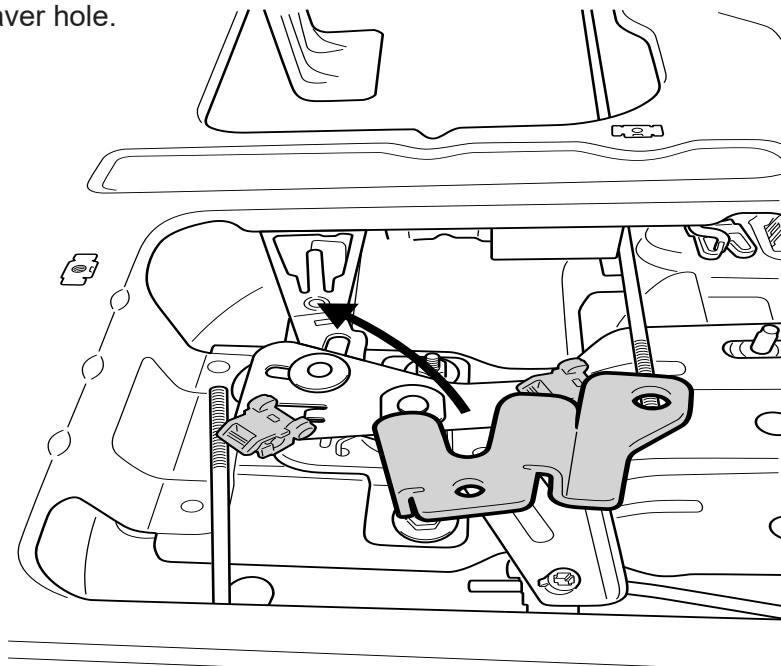

— Step 8 —

Feed M5 x 25mm pan head screw
through bracket and lever.

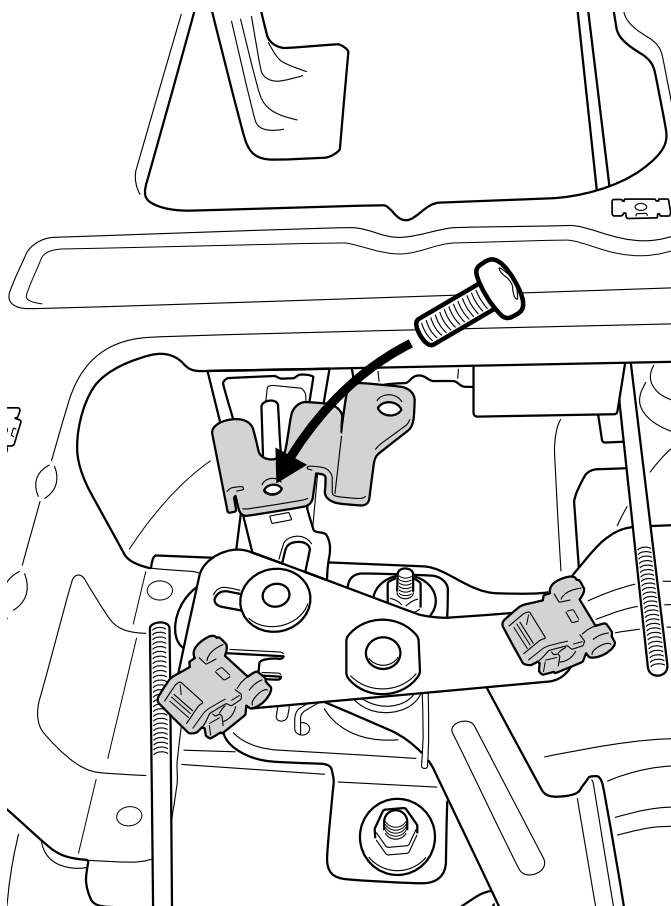

— Step 9 —

To the underside of the lever feed M5 washer through M5 pan head screw and fasten into position using the M5 nut. Note: Torque to 3Nm.

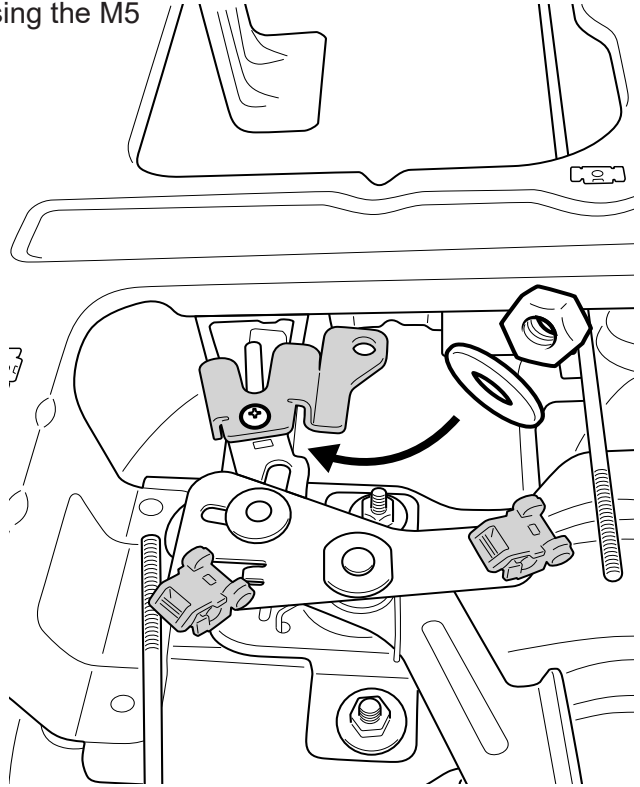

— Step 10 —

Hook trough rod (NRGR18-C) to indicated location.

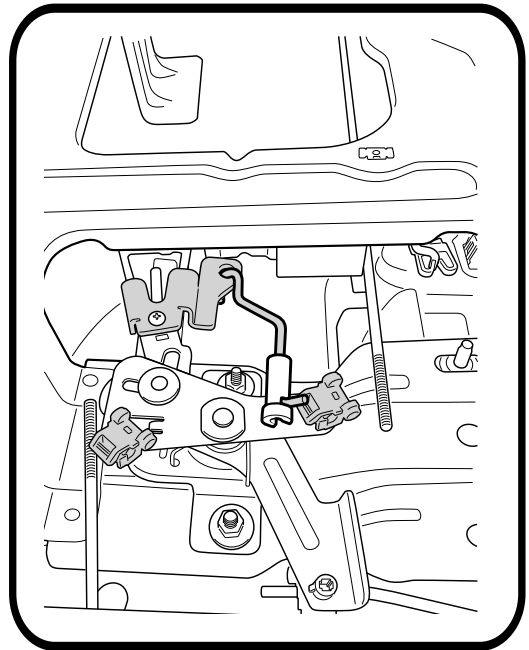
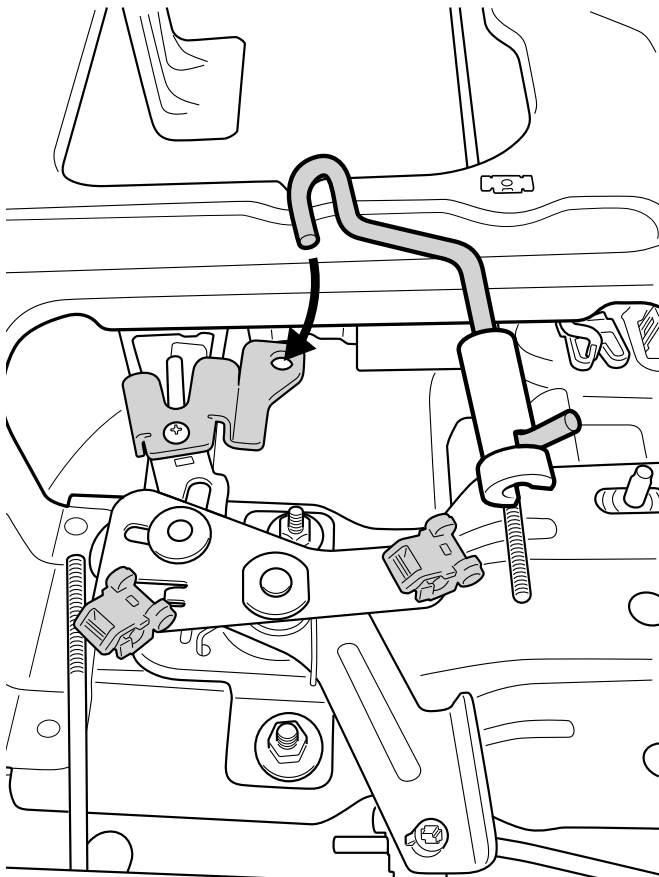

— Step 11 —

Re-fit factory rods.

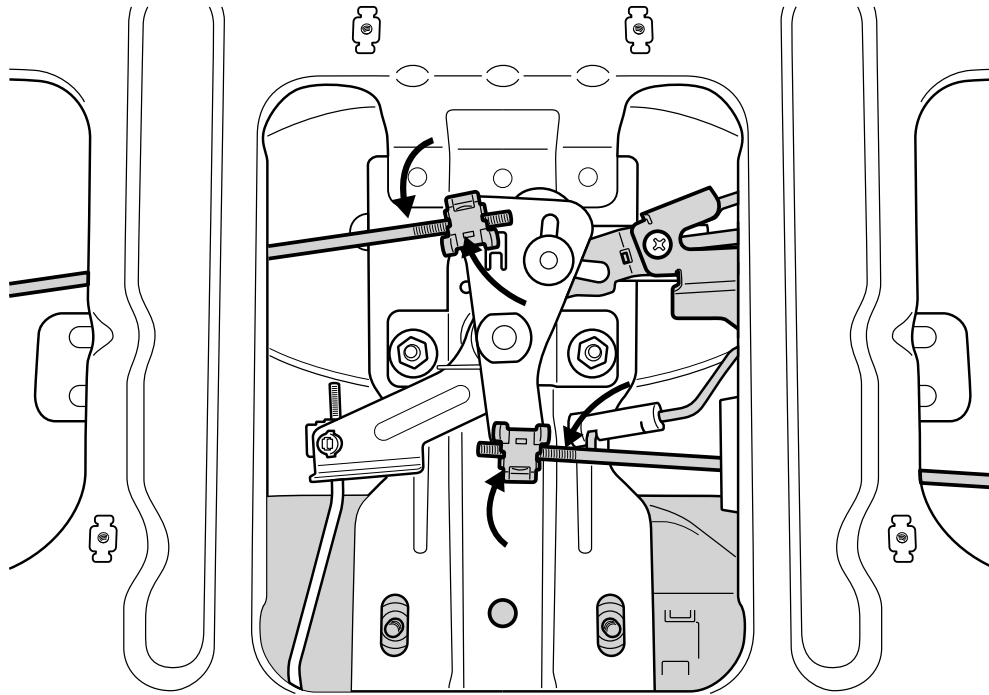

— Step 12 —

Align bracket (NGR18-A) to indicated location.

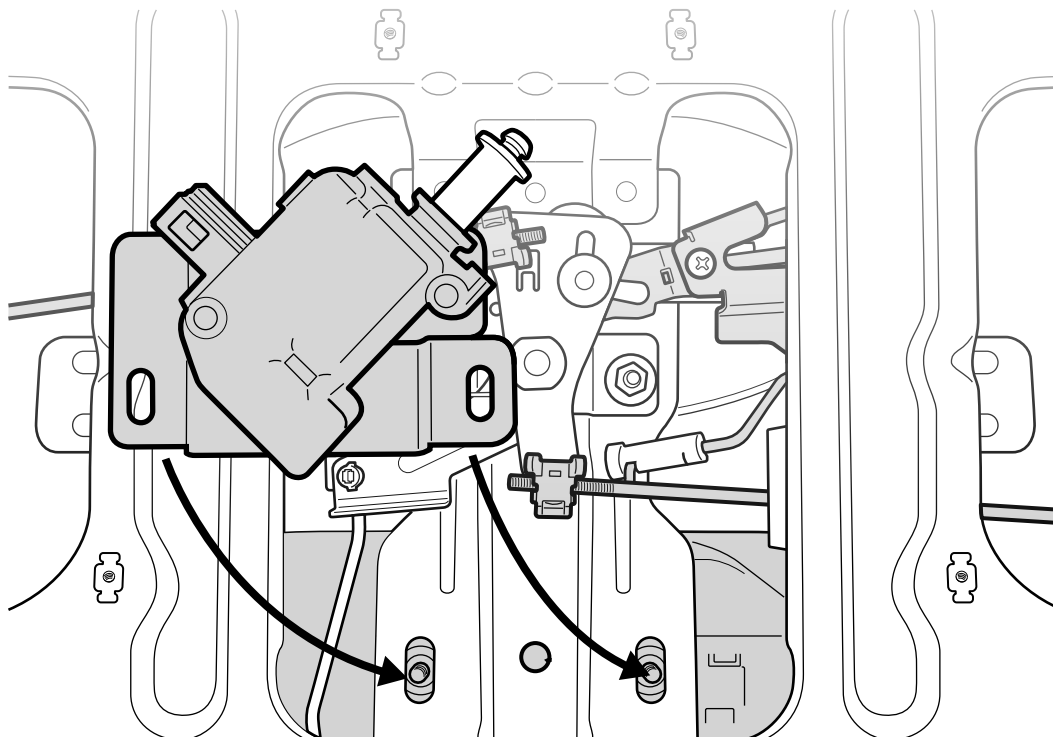

— Step 13 —

Fasten into position using retained factory hardware.

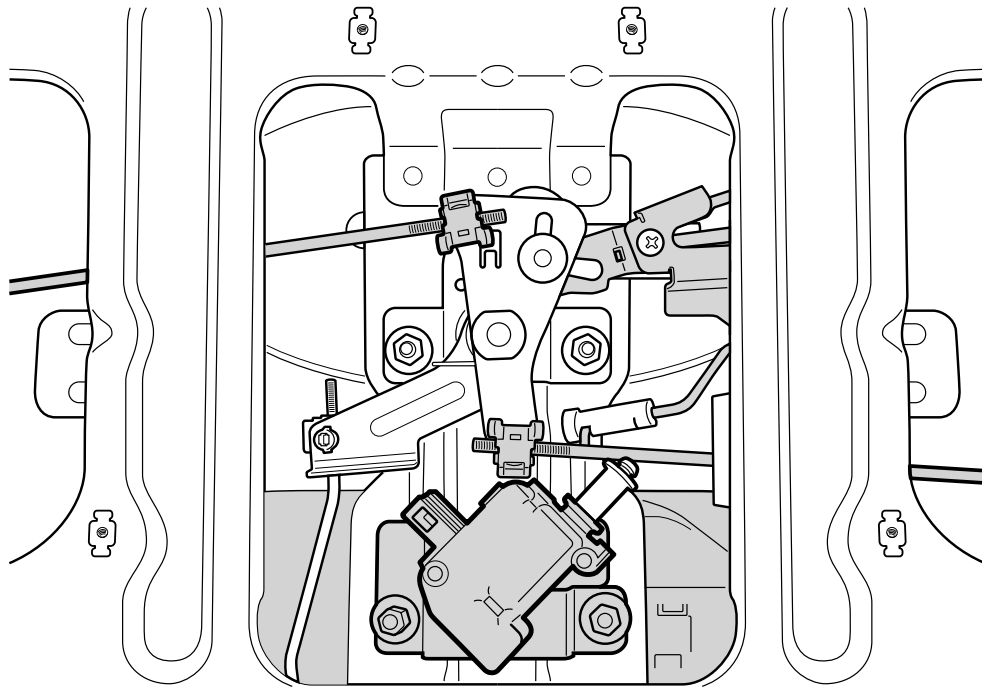

— Step 14 —

Align & push plastic striker (ACT-01-C) on to actuator (ACT-01) until it clicks into position .

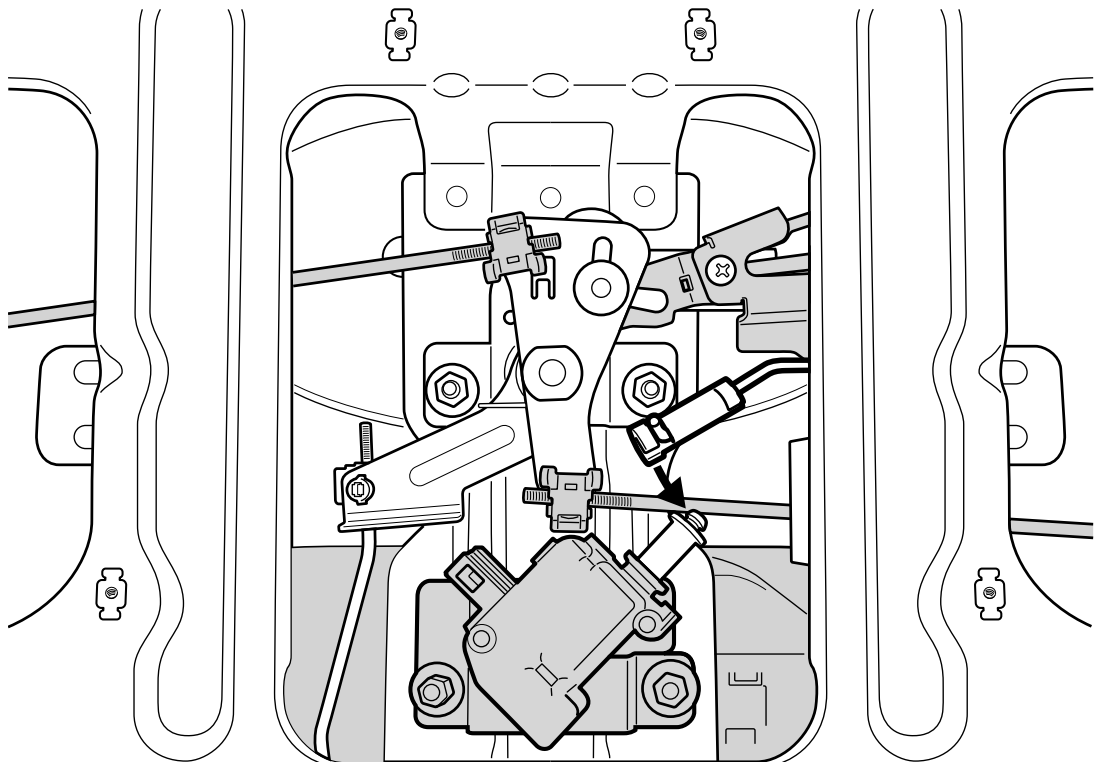

Note: ACT-01-C will sit over factory pull rod.

— Step 15 —

Connect CL-LOOM-SHORT to actuator (ACT-01)

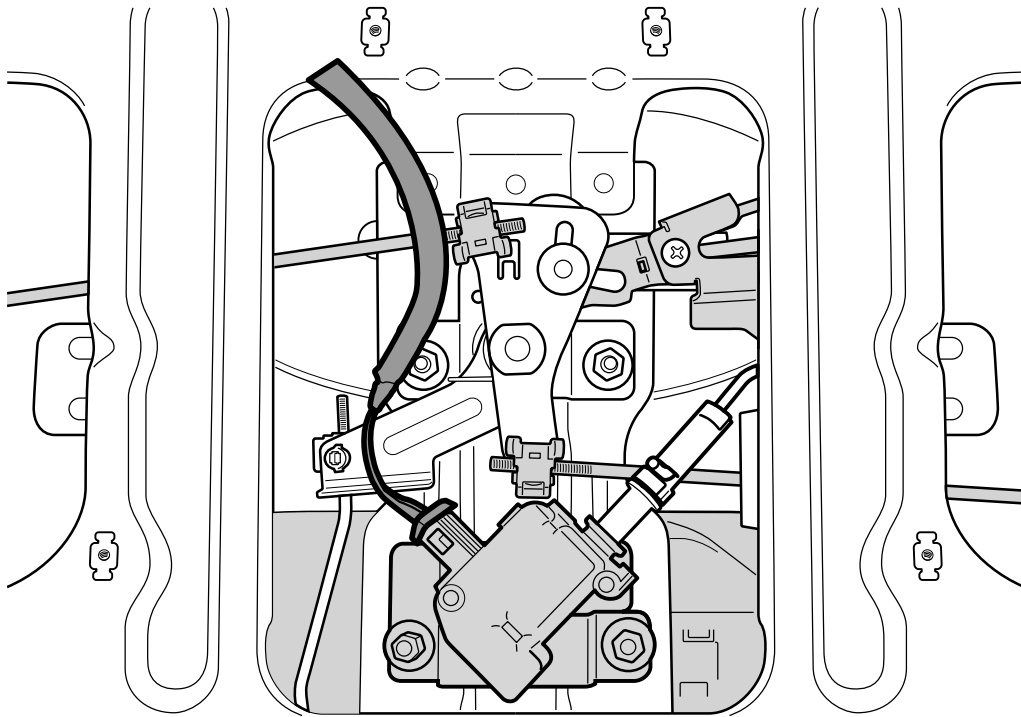

— Step 16 —

Run CL-LOOM-SHORT tailgate through and under the tub.

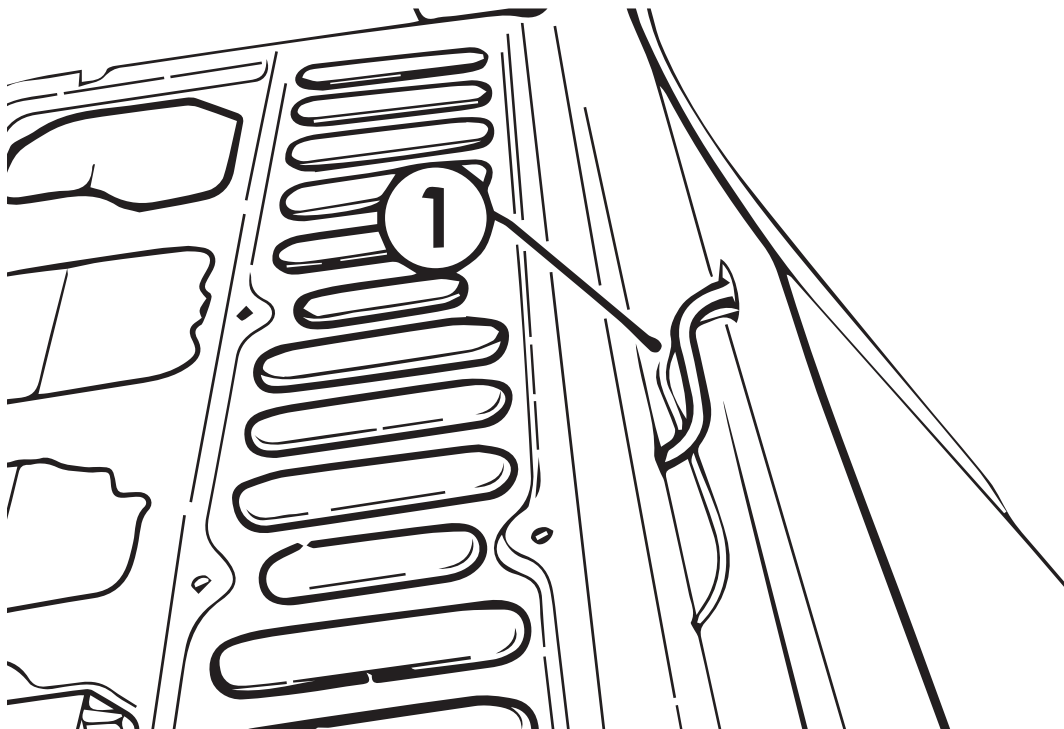

— Step 17 —

Run CL-LOOM-SHORT from tailgate to fuel cap. Use cable ties every 400mm.

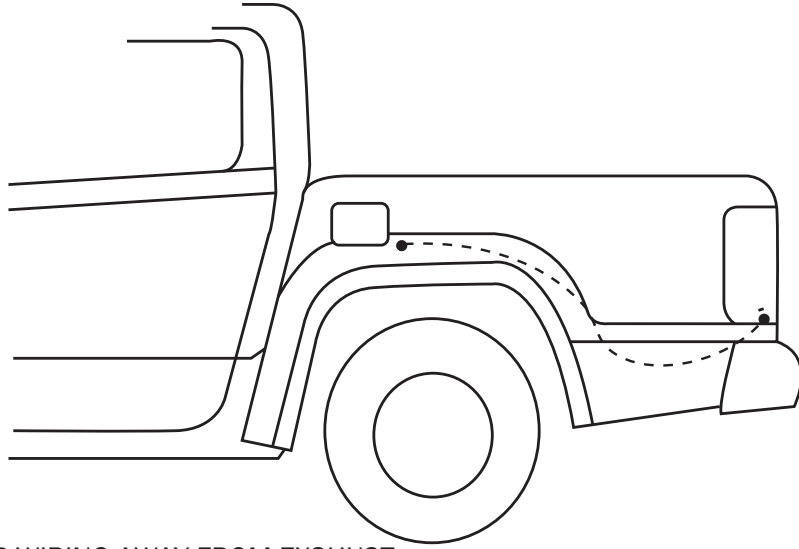

NOTE: KEEP WIRING AWAY FROM EXSHUST

Step 18

Remove required clips to gain access to passenger side rear wheel arch inner.

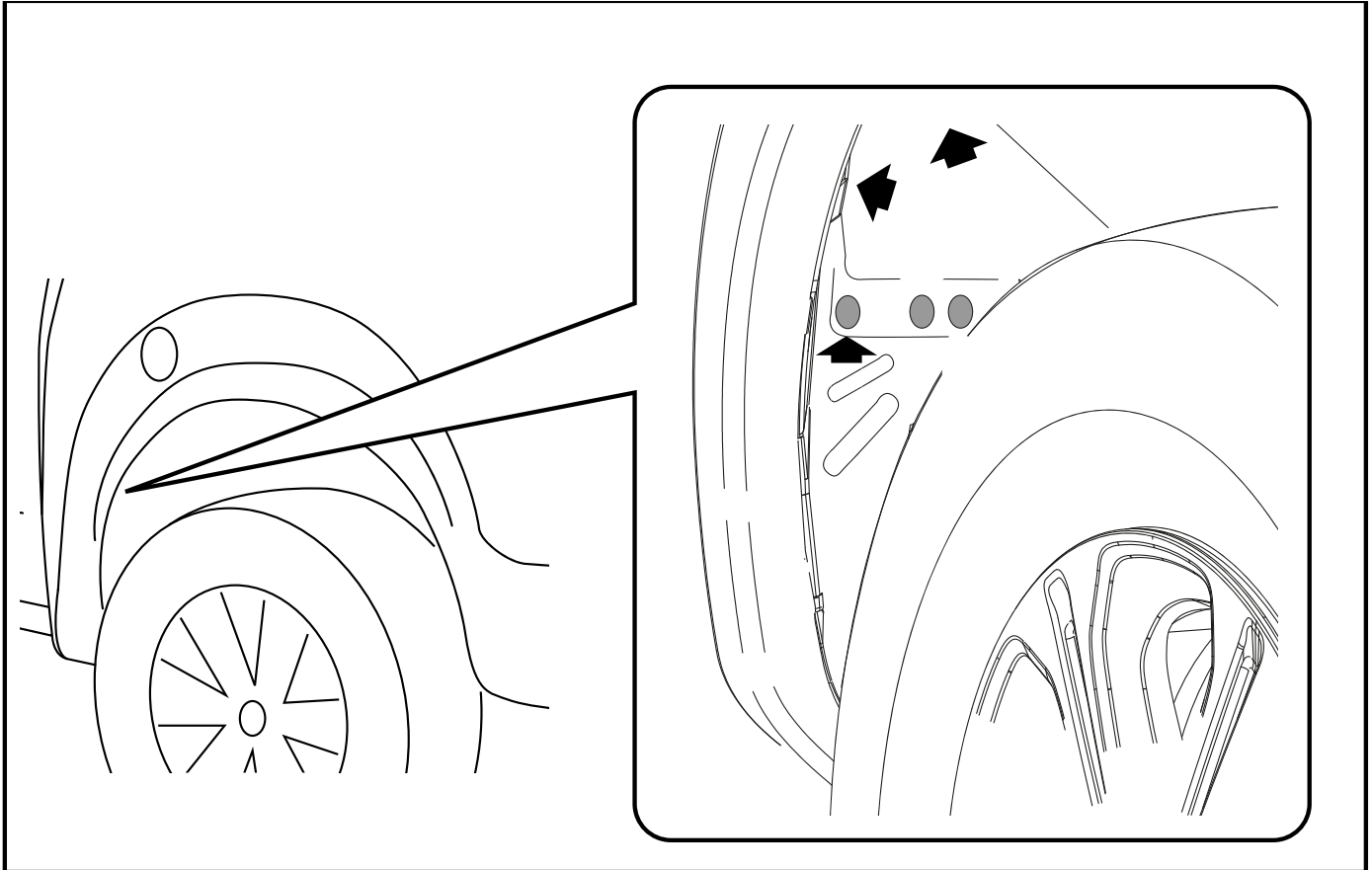

NOTE: image used is for illustration purpose only.

1. Disconnect the fuel flap actuator connector (1).
2. Patch the NGR-Patch to fuel cap actuator connector and actuator connector.
3. Use one zip tie to secure the harness to the existing harness.
4. Connect CL-Short-Loom to NGR-Patch. Zip tie any loose loom within wheel arch.

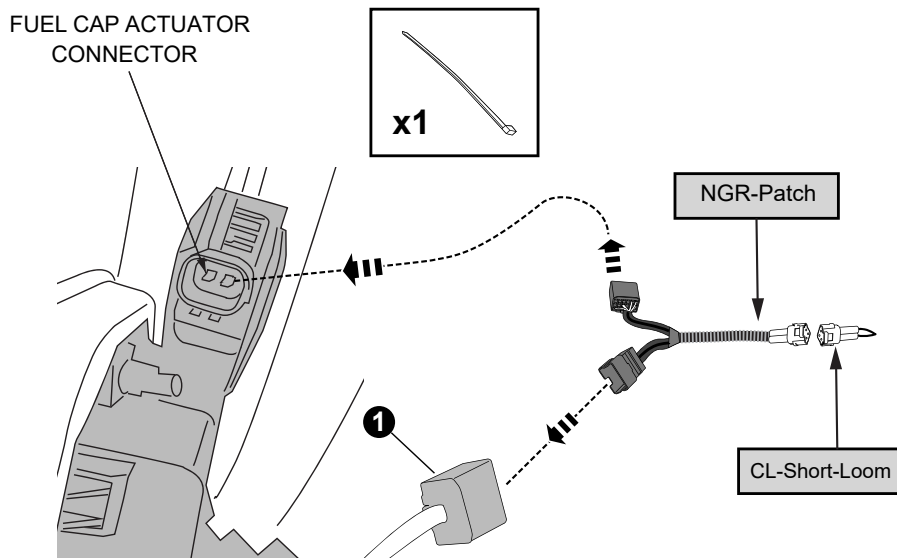

NOTE: image used is for illustration purpose only.

Re-fit tailgate cover.

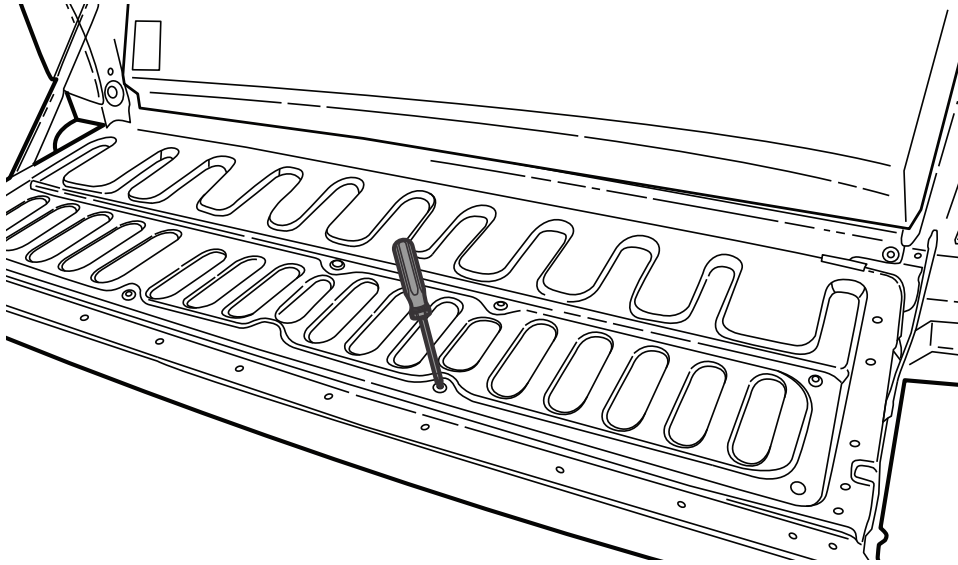

— FITTING COMPLETED —
