



# INSTALLATION INSTRUCTIONS

**To suit Jeep Gladiator  
(With No Trail Rail System)**



**INSTALLATION TIME:** 1 hours and 45 minutes (Approximately)

<b>IMPORTANT</b>	<ul style="list-style-type: none"> <li>• Do not stand/sit or rest heavy objects on Roll R Cover</li> <li>• Humans or animals are not to be under the closed cover at any given time</li> <li>• Tonneau Cover is not dust or water tight</li> <li>• If contact with volatile chemicals occur, clean Cover with mild detergent and water solution</li> </ul>			
<b>Care Instructions</b>	<ul style="list-style-type: none"> <li>• Read Instructions fully before commencing installation.</li> <li>• Clean Cover with a mild detergent and water solution</li> <li>• Do not use abrasive cleaners or solvents</li> <li>• Refer to manufactures instructions applicable to power drill.</li> <li>• Protect Tub floor against scratches during installation process.</li> </ul>			
<b>Maintenance</b>	Refer to Maintenance instructions.			
<b>Tools Required</b>	<table style="width: 100%; border: none;"> <tr> <td style="vertical-align: top;"> <ul style="list-style-type: none"> <li>• Pen / Marker</li> <li>• Centre Punch</li> <li>• Drill &amp; Drill bits</li> <li>• Caulking Gun</li> <li>• Silicon - Non Acetic</li> </ul> </td> <td style="vertical-align: top;"> <ul style="list-style-type: none"> <li>• Scissors &amp; Knife</li> <li>• Spanner &amp; Socket</li> <li>• Tape measure</li> <li>• Holesaw</li> <li>• Filing tool</li> </ul> </td> <td style="vertical-align: top;"> <ul style="list-style-type: none"> <li>• Soapy water solution</li> <li>• Allen Key set</li> <li>• Screw driver</li> <li>• Rust Inhibitor</li> <li>• Trim Removal Tool</li> </ul> </td> </tr> </table>	<ul style="list-style-type: none"> <li>• Pen / Marker</li> <li>• Centre Punch</li> <li>• Drill &amp; Drill bits</li> <li>• Caulking Gun</li> <li>• Silicon - Non Acetic</li> </ul>	<ul style="list-style-type: none"> <li>• Scissors &amp; Knife</li> <li>• Spanner &amp; Socket</li> <li>• Tape measure</li> <li>• Holesaw</li> <li>• Filing tool</li> </ul>	<ul style="list-style-type: none"> <li>• Soapy water solution</li> <li>• Allen Key set</li> <li>• Screw driver</li> <li>• Rust Inhibitor</li> <li>• Trim Removal Tool</li> </ul>
<ul style="list-style-type: none"> <li>• Pen / Marker</li> <li>• Centre Punch</li> <li>• Drill &amp; Drill bits</li> <li>• Caulking Gun</li> <li>• Silicon - Non Acetic</li> </ul>	<ul style="list-style-type: none"> <li>• Scissors &amp; Knife</li> <li>• Spanner &amp; Socket</li> <li>• Tape measure</li> <li>• Holesaw</li> <li>• Filing tool</li> </ul>	<ul style="list-style-type: none"> <li>• Soapy water solution</li> <li>• Allen Key set</li> <li>• Screw driver</li> <li>• Rust Inhibitor</li> <li>• Trim Removal Tool</li> </ul>		

**PERSONAL PROTECTIVE EQUIPMENT:**



Rubber Gloves





Goggles





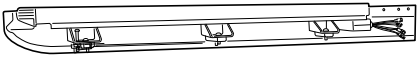
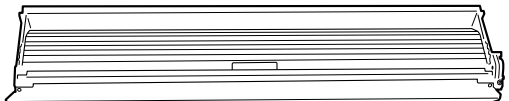







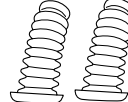

Hearing Protection

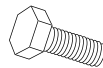
# BOX CONTENTS

<p><b>LEFT &amp; RIGHT SIDE RAIL</b></p> <p>S2.5-DC-AE-002ps-J4R </p> <p>S2.5-DC-AE-003ds-J4R </p>	<p><b>CANISTER ASSEMBLY</b></p>  <p>S3-XC-AF-001/002_J4</p>
<p><b>CANISTER TOP COVER</b>  <b>S2.5-DC-AE-005 -J4</b></p>	

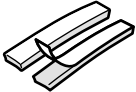
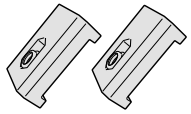
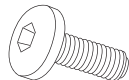
## SPECIFIC KIT J4R

<p><b>COVER END CAPS</b></p>  <p>S2.5-DC-PI-004ps</p>  <p>S2.5-DC-PI-004ds</p>	 <p><b>COUNTERSUNK SCREW Qty - 4</b></p>	 <p><b>CABLE TIE Qty x 16</b></p>	 <p><b>BATTERY LOOM S2.75</b></p>	 <p><b>Drainage pipe Qty - 2</b></p>	 <p><b>Foam seal Qty - 1.7m</b></p>
 <p><b>Chanel nut Qty- 6</b></p>	 <p><b>M8 x 20mm Qty- 6</b></p>	 <p><b>M8 Spring washer Qty- 6</b></p>	 <p><b>M8 Flat washer Qty- 6</b></p>	 <p><b>CL-LOOM-SHORT</b></p>	 <p><b>J-PATCH</b></p>
 <p><b>50449 D-SPONGE Qty-2</b></p>	 <p><b>SIDERAIL CLAMP Qty - 6</b></p>	 <p><b>M8 x 35mm Qty - 6</b></p>	 <p><b>M8 WASHER Qty - 6</b></p>	 <p><b>M8 SPRING WASHER Qty - 6</b></p>	

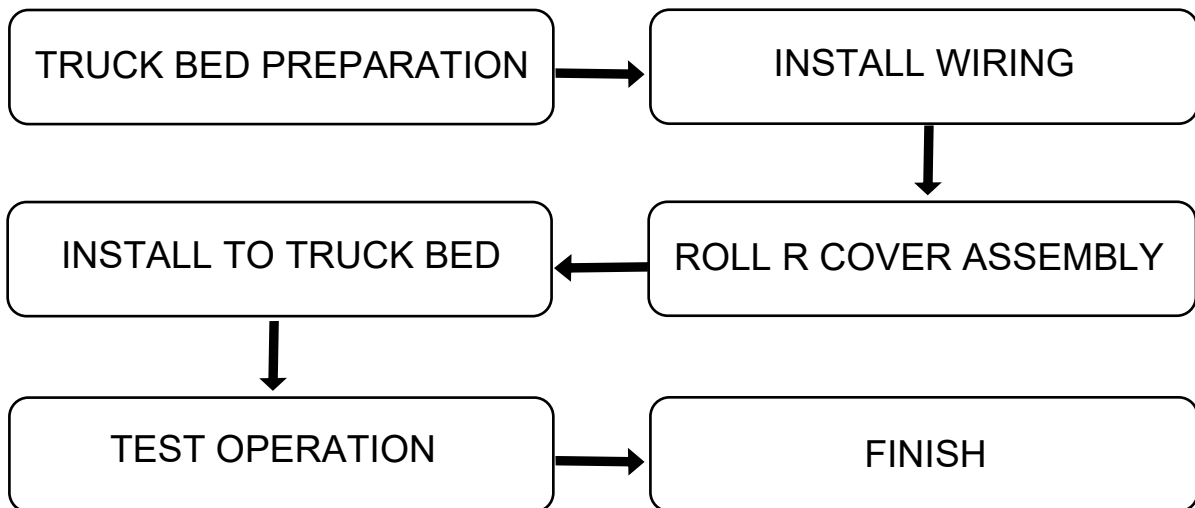

## TUB PREPARATION

Clean are as indicated.

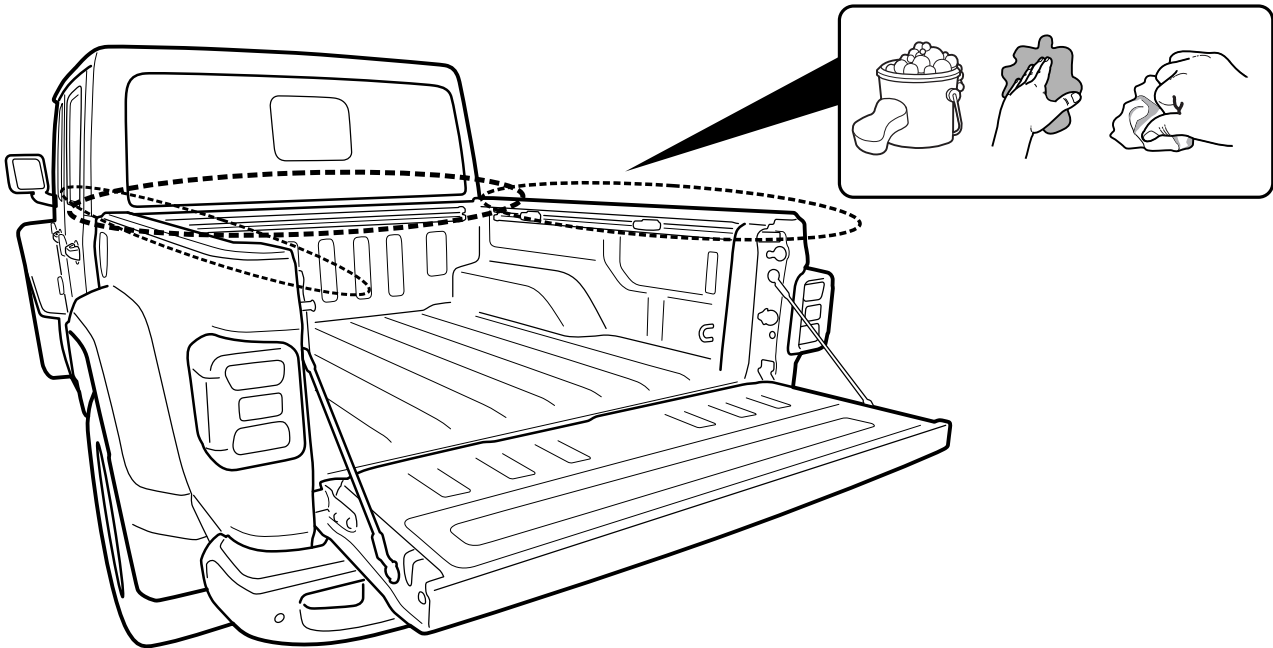

**Drill the indicated hole to 19mm**

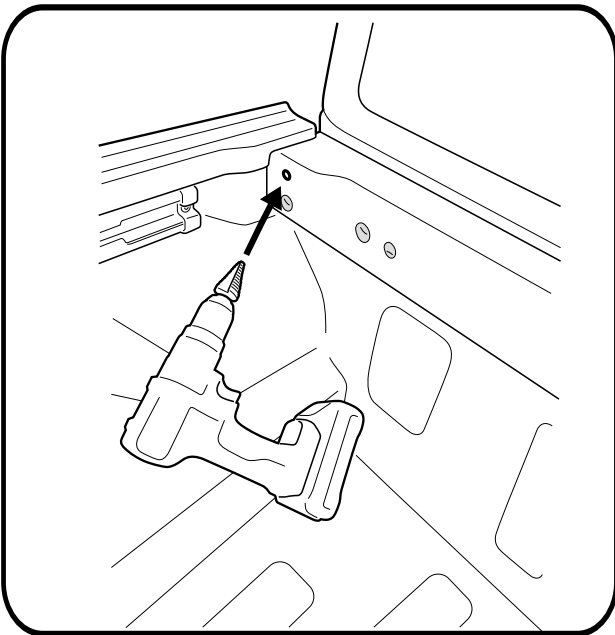

**Apply rust inhibitor**

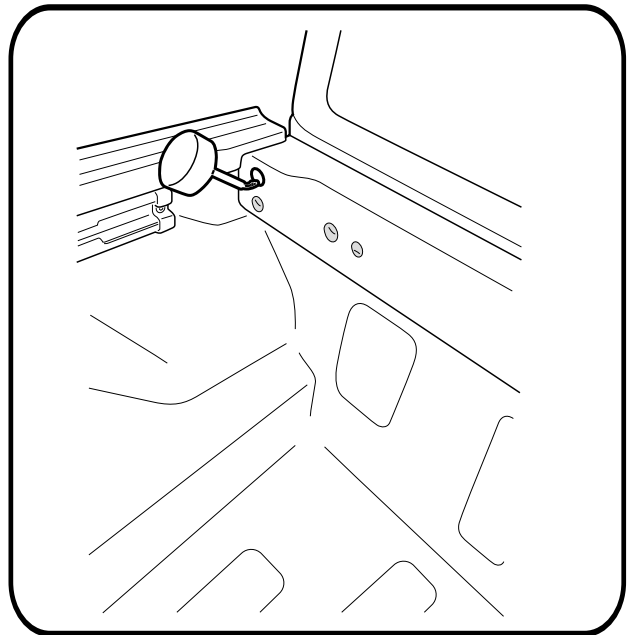

Measure down from top of headboard 210mm & 135mm from inside wall of bed as shown.  
( or 115mm if measuring from the side of the top rail) Repeat to the other side.  
Using a 30mm hole-saw drill through tub front panel, file away any sharp edges. Apply anti rust coating. Repeat to other side.

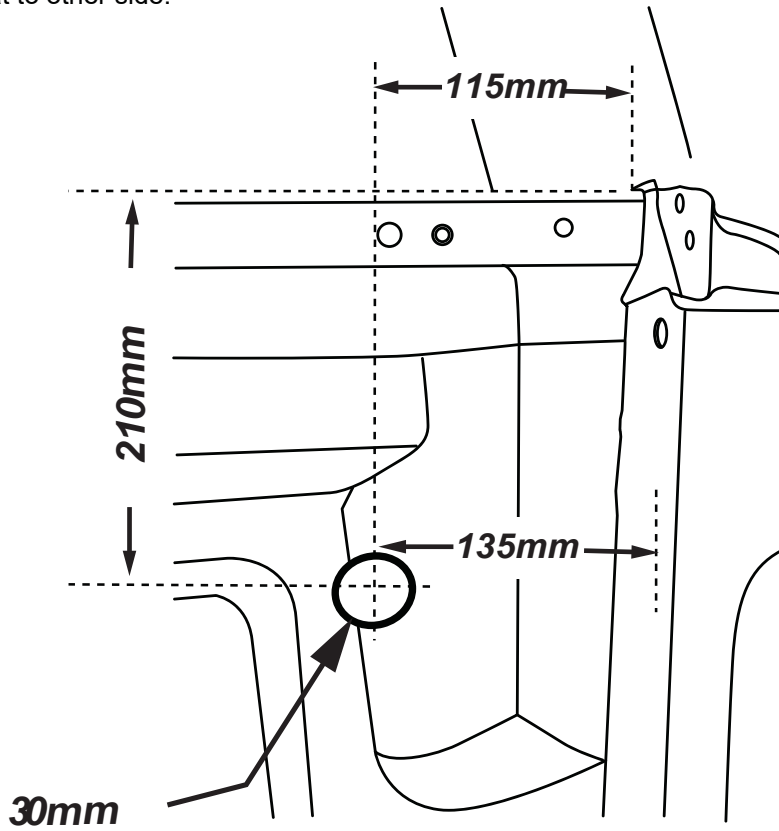

 **ATTENTION:** Do not exceed 30mm hole.

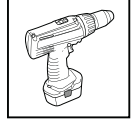
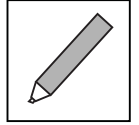
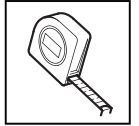

Carefully unpack the box.

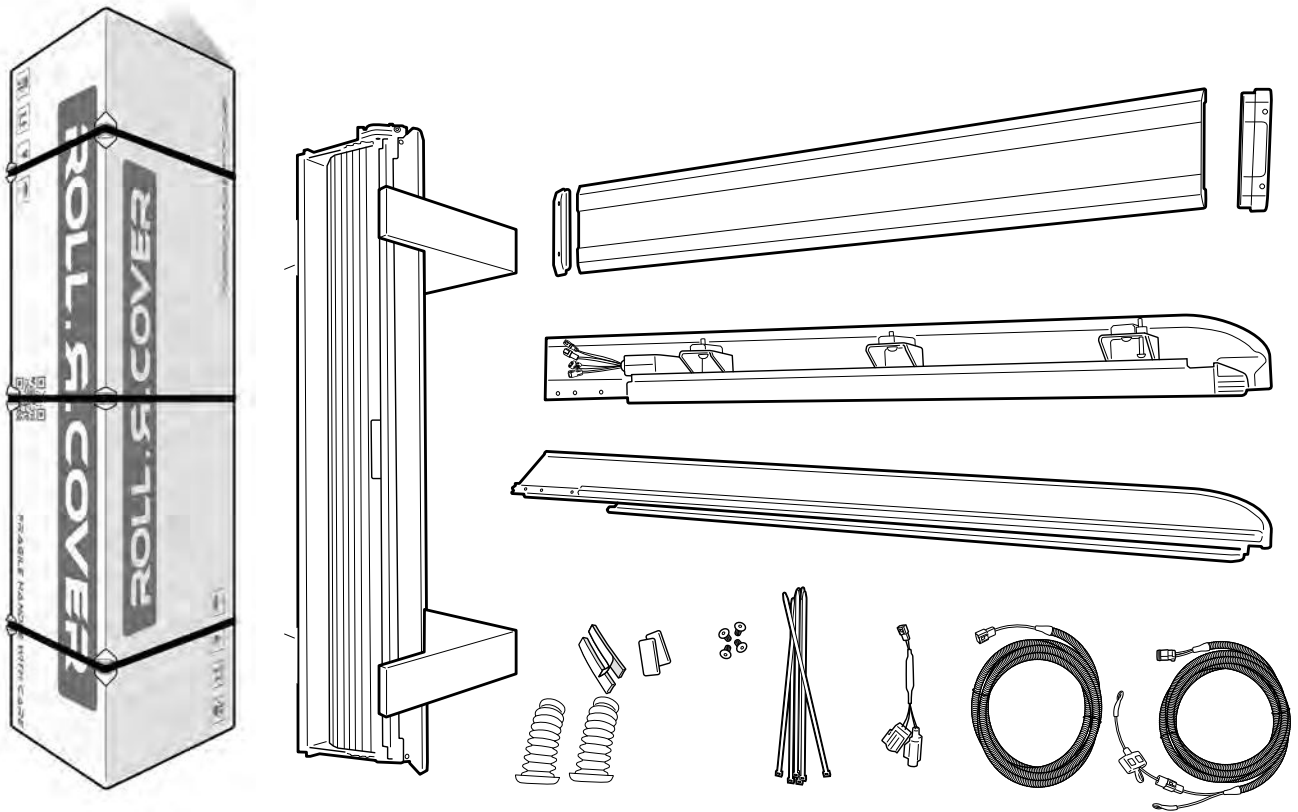

Install front drain pipes ( 55mm diameter end of hose)  
through pre-drilled holes on the front tub panel.



Note: With care push tube in.  
Taking care pull the tube back so it seals  
correctly against the front panel of the tub.

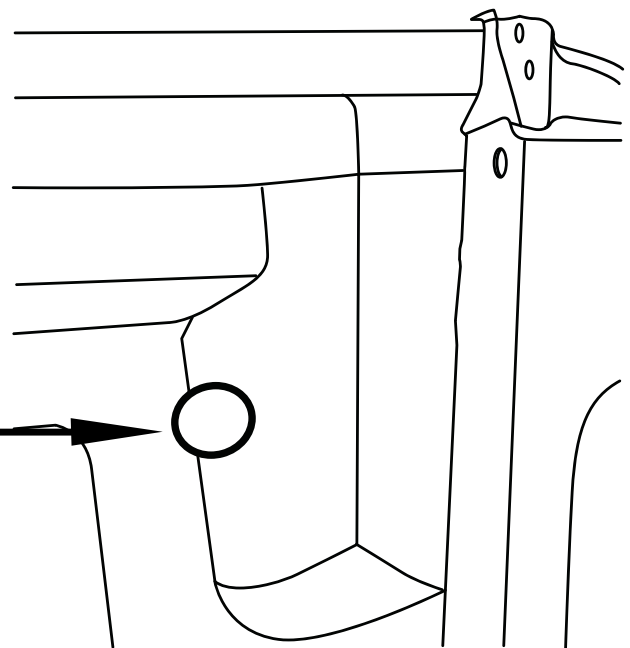
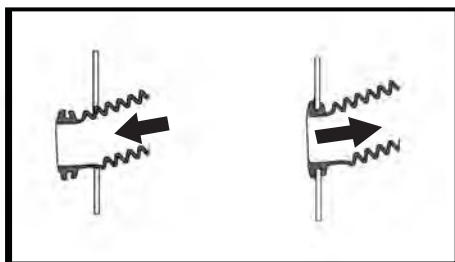

Disconnect fuse patch from battery loom S2.75.

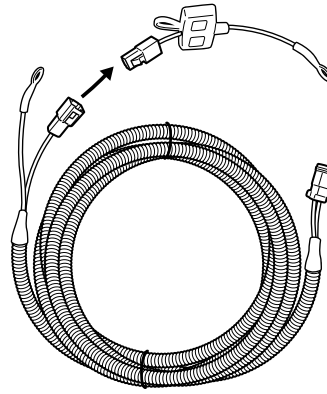

**Wiring Harness steps**

**1** Feed loom through previously drilled hole.

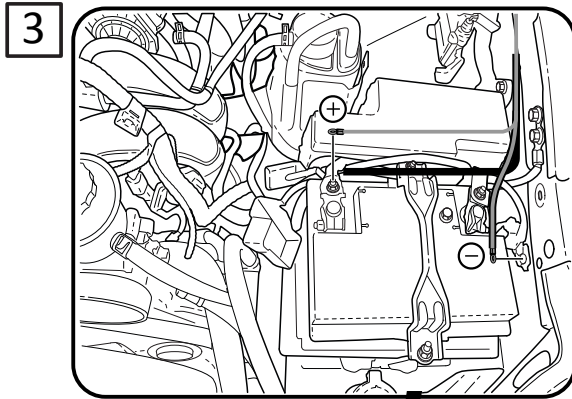
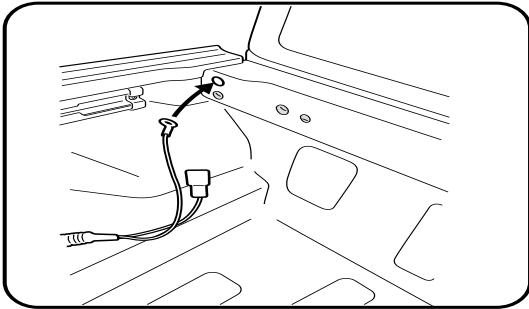

**2**

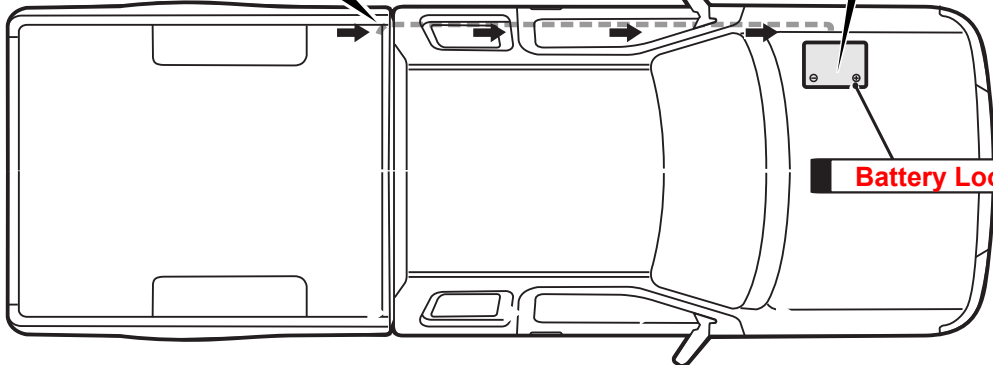

Run the wiring from the front corner cavity ( leaving 200mm in the tub) to the battery over the chassis rail. Making sure to keep away from hot obstructions and cable tie every 400mm. Reconnect fuse patch to battery loom S2.75, now attach fuse patch to positive of battery and earth to the body of the Ute.

Feed CL-Short-Loom through the pre-drilled hole.

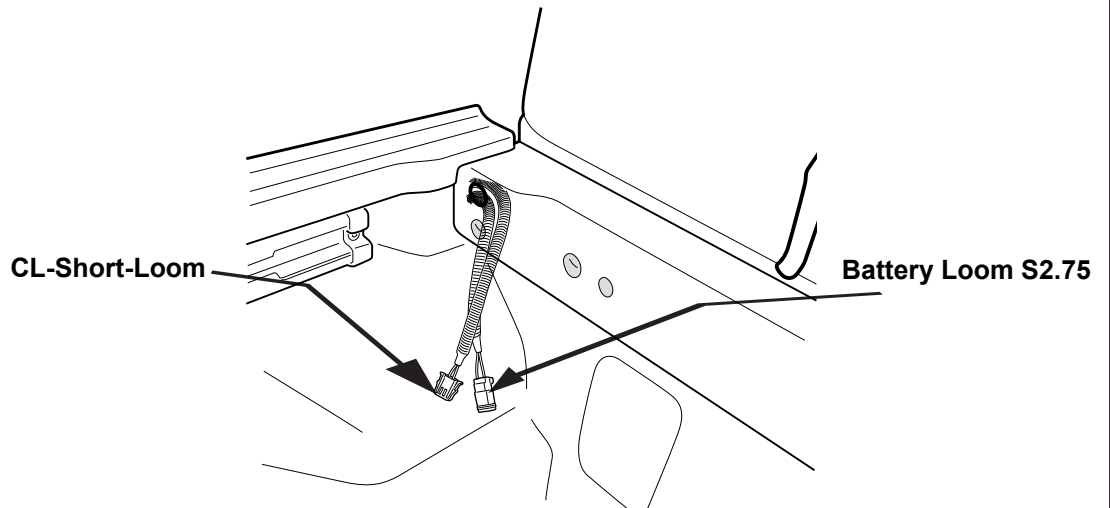

Run foam seal provided along the front ( inside edge towards tailgate) of the tub to make head-rail level with sides.

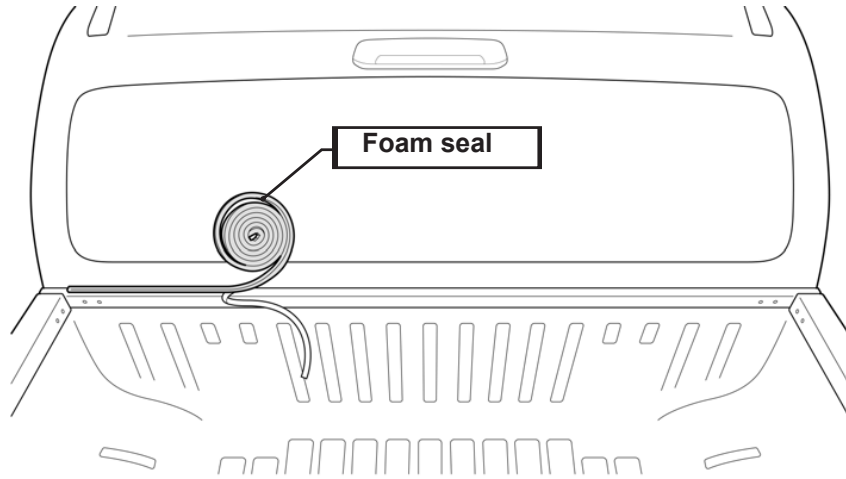

Remove tail gate cover. Locate connector plugged into factory actuator behind tailgate handle.

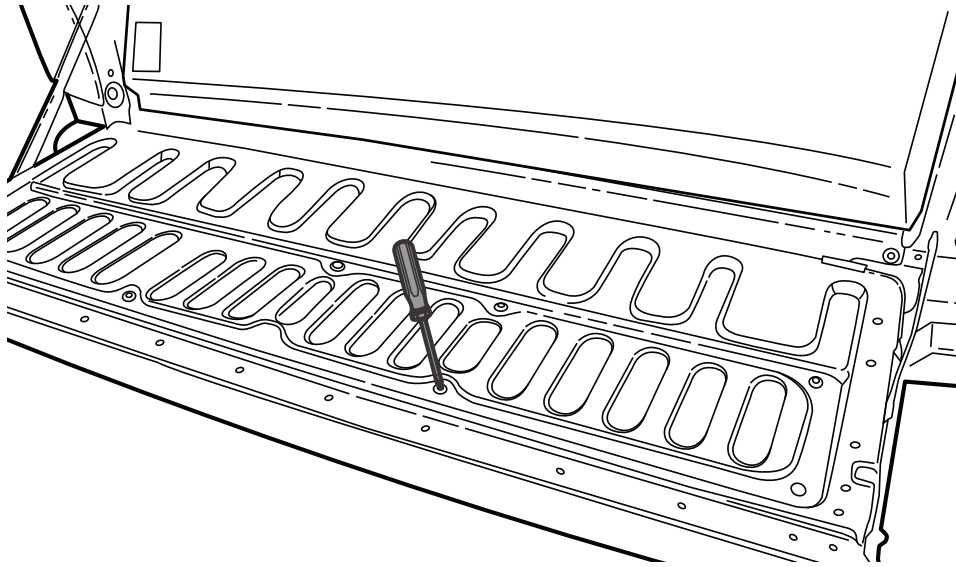

Run CL-short loom harness into the tailgate. Cable tie along the way to secure the harness.

1. Connect J-Patch to actuator.
2. Connect factory loom to J-patch.
3. Connect J-patch to CL-Short-Loom.

EXISTING VEHICLE  
HARNESS  
CONNECTORS

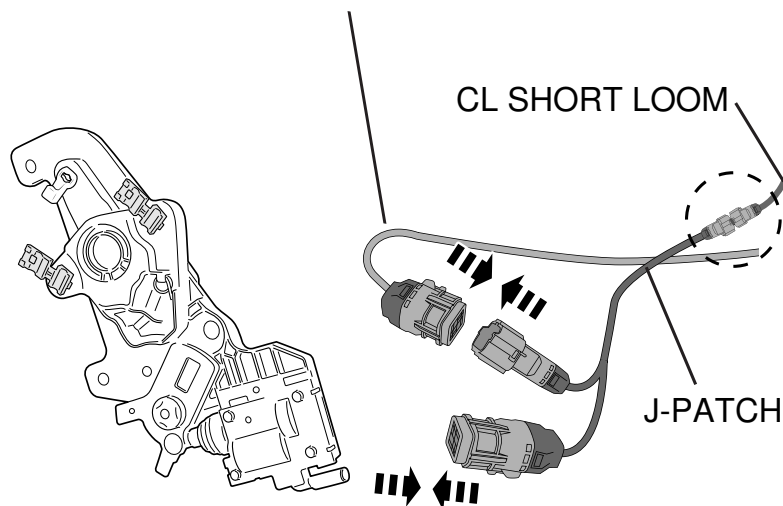

keep the cannister in the foam blocks from the packaging for assembly.

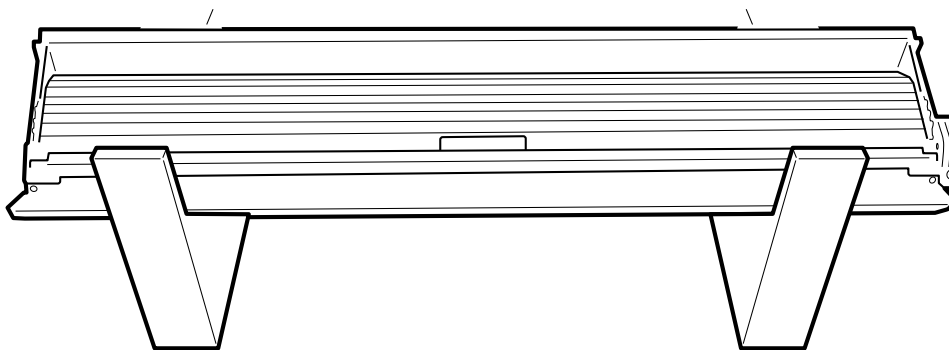
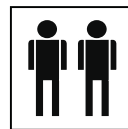

With assistance turn the canister on its back on the foam blocks.

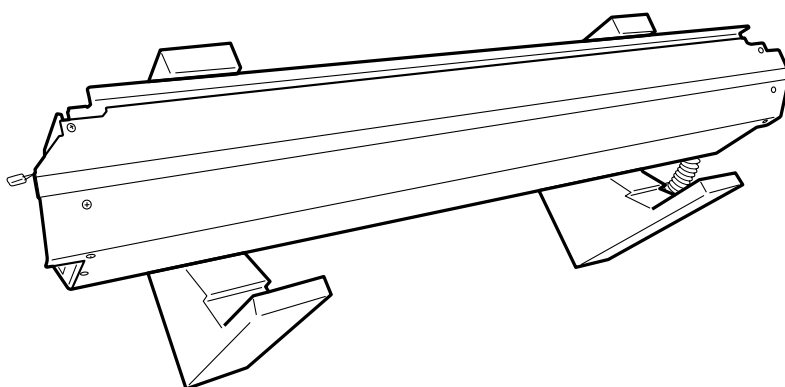

Disengage motor from the axle by unfastening the 3 Screw as indicated. Retain all parts.

Remove and retain the 3 screw from the canister as indicated.

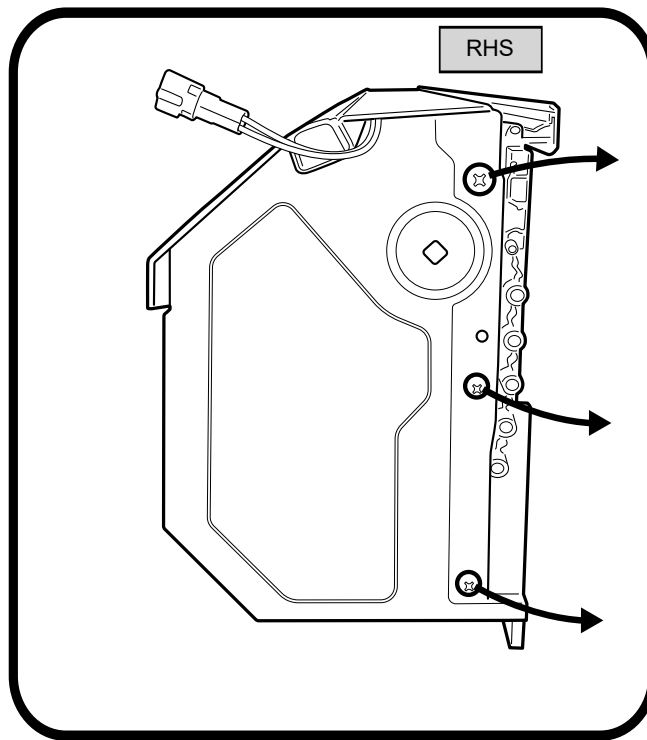
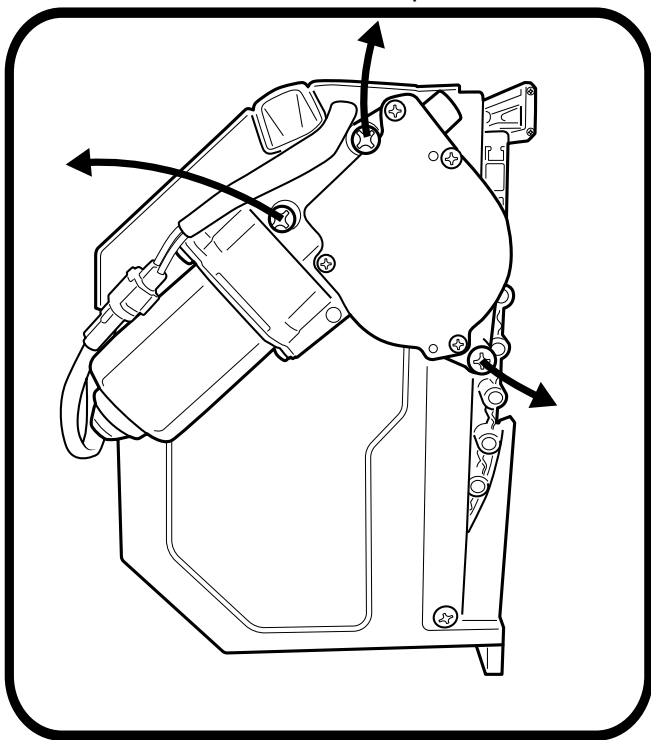
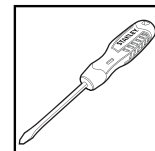



Now on the other side, remove and retain the 4 screws from the canister as indicated.

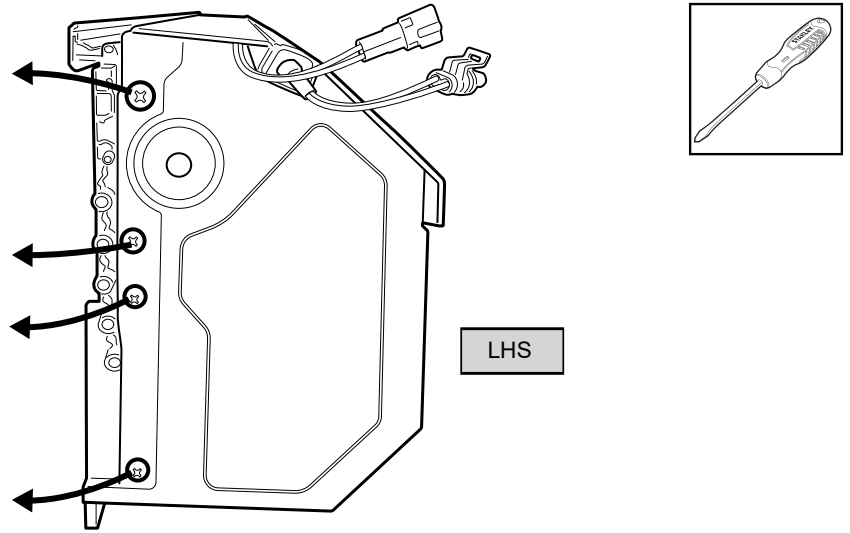

Align side rail to side of canister, guide the track to go in between the curtain end rubber stop.

NOTE: LHS side rail to be assembled first.

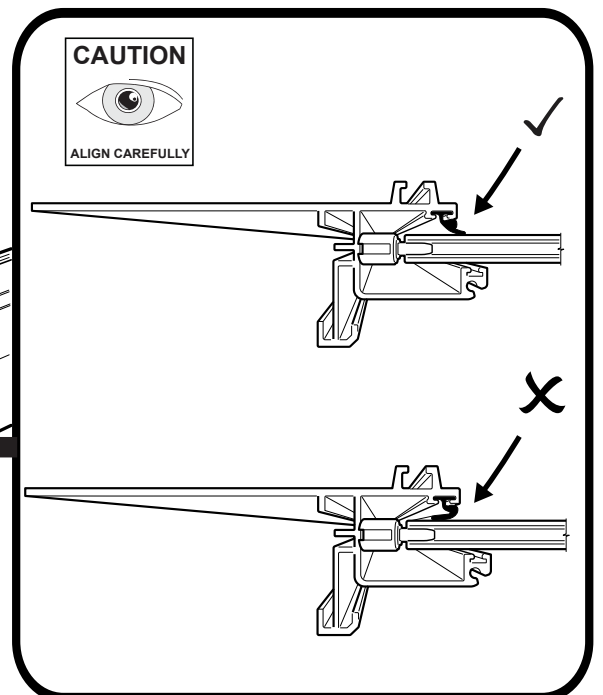
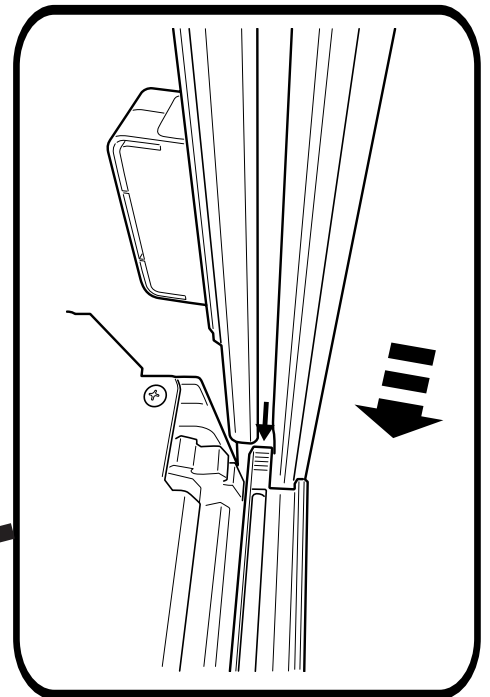
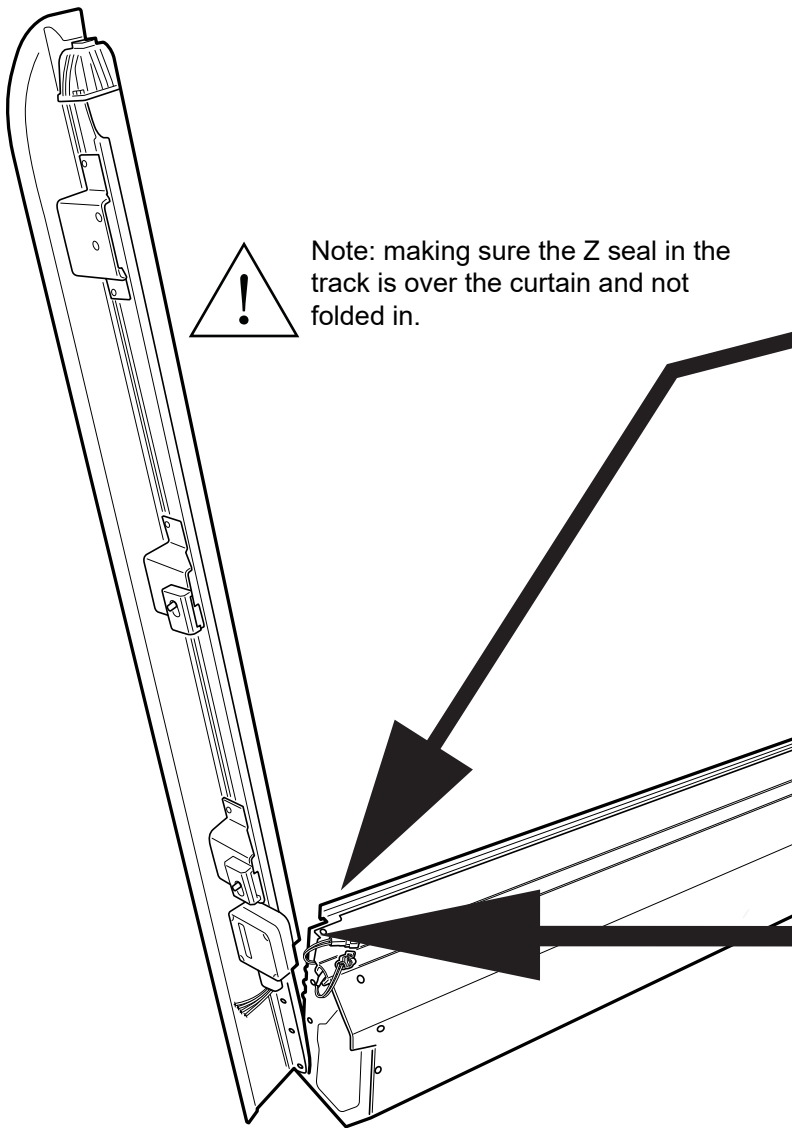

Fasten the side rail using the retained screws, spring washer and flat washer.

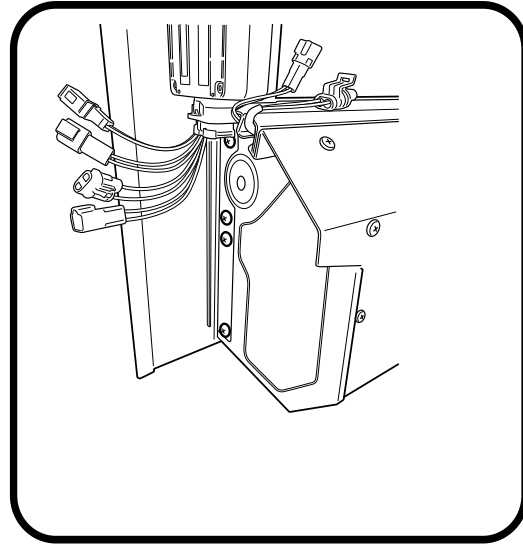
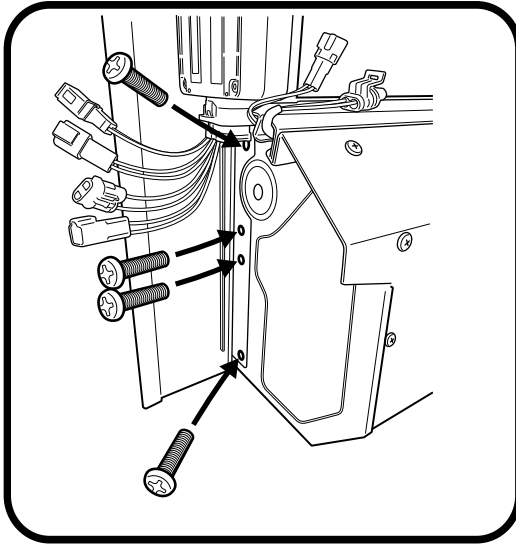
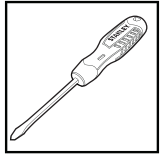

Connect motor receiver

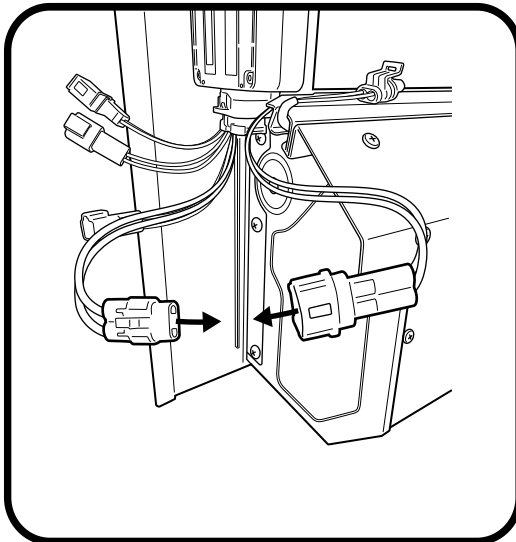

Connect LED Loom to receiver

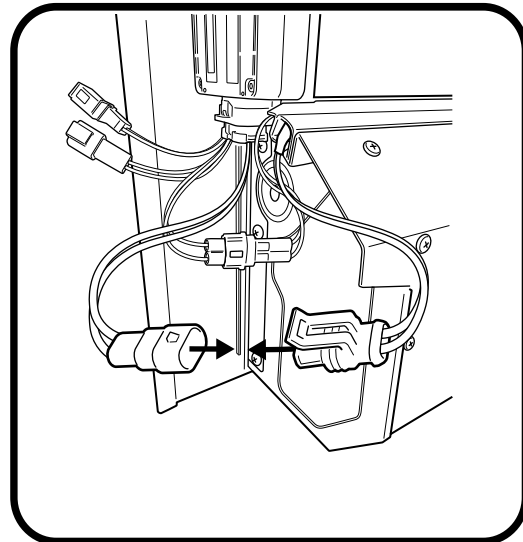

Align side rail to side of canister, guide the track to go in between the curtain end robber stop.

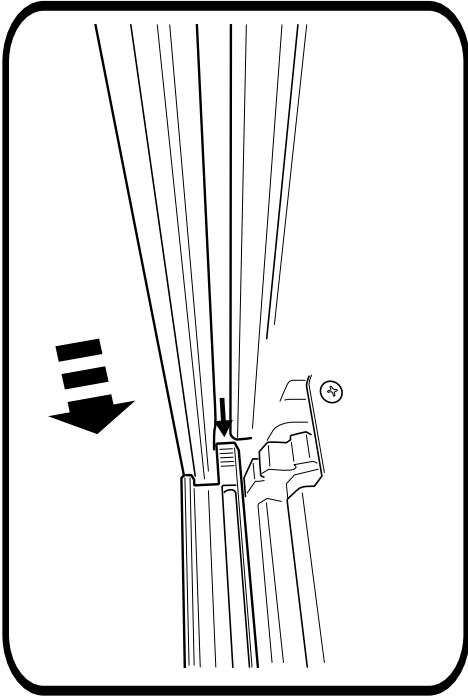

Note: making sure the Z seal in the track is over the curtain and not folded in.

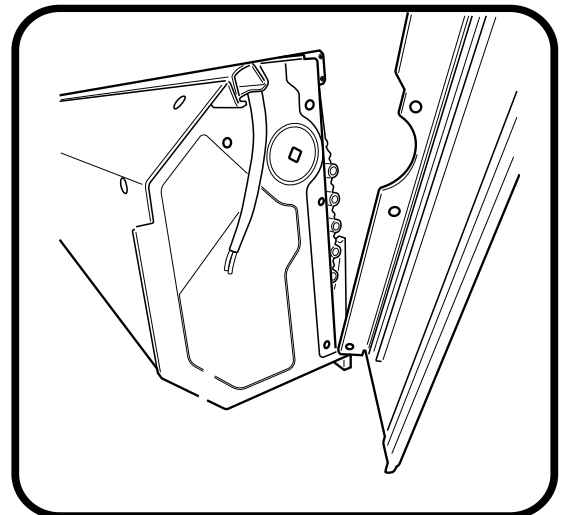
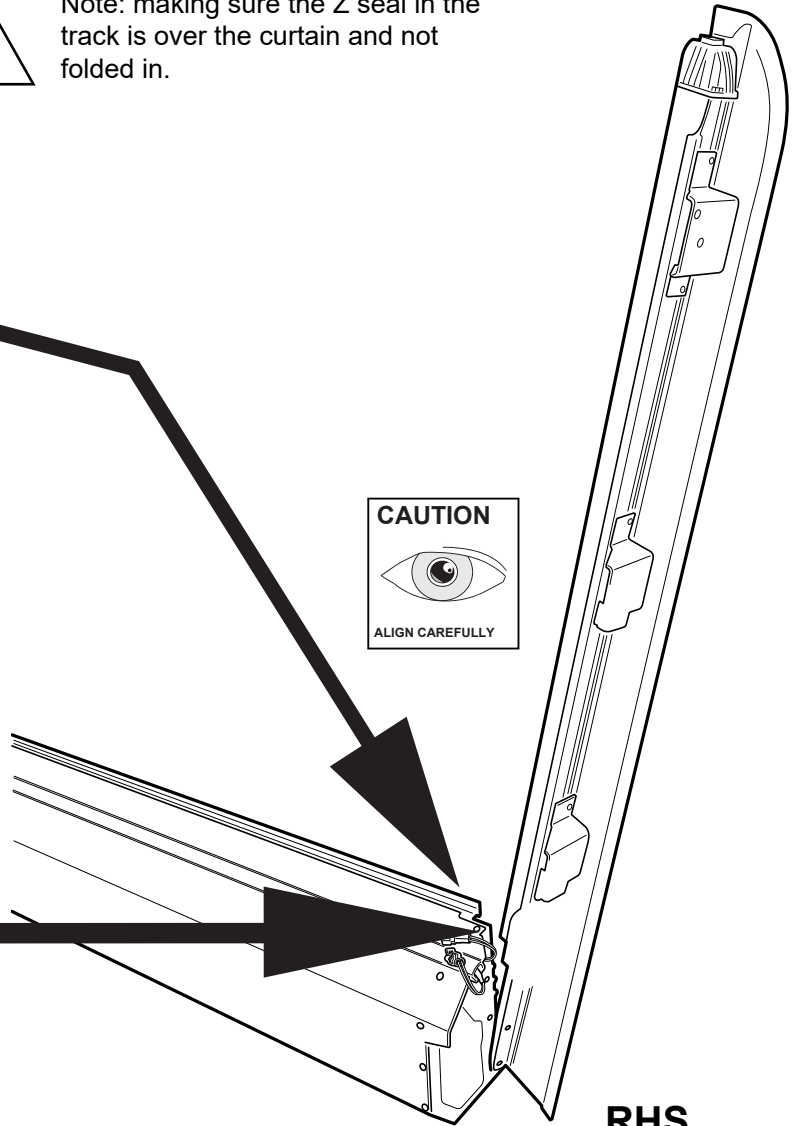
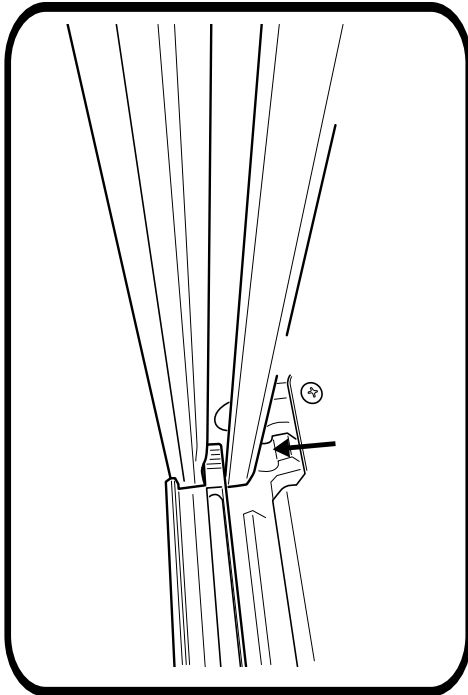

Fasten the side rail using the retained screws, spring washer and flat washer, only to the locations indicated.

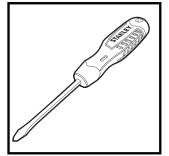
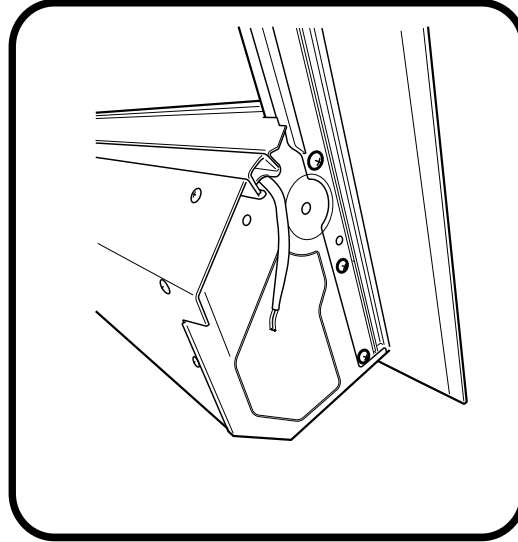
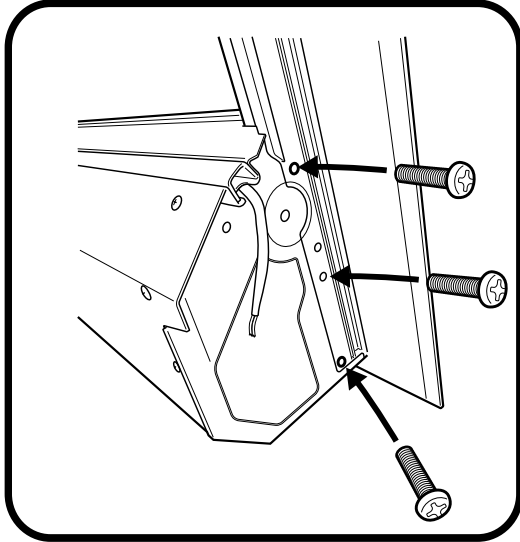

Feed M6 bolt through spring washer, motor and rubber bush.

**NOTE:** Rubber bush orientation has to be as per image. ( side with text on rubber, to face the motor).

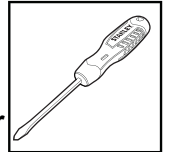
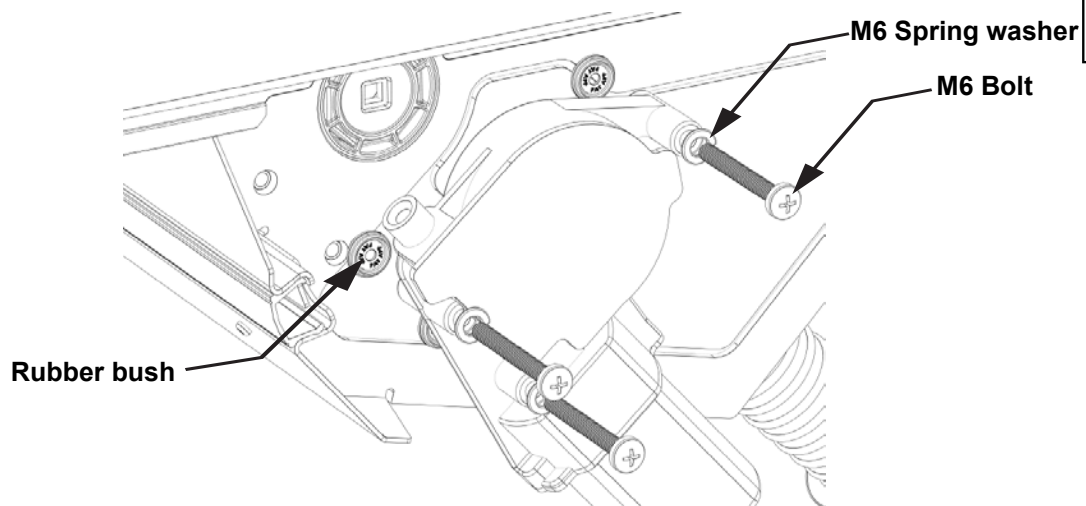

Align & insert motor shaft to axle.

**NOTE:** Pull / push curtain for axle to rotate.

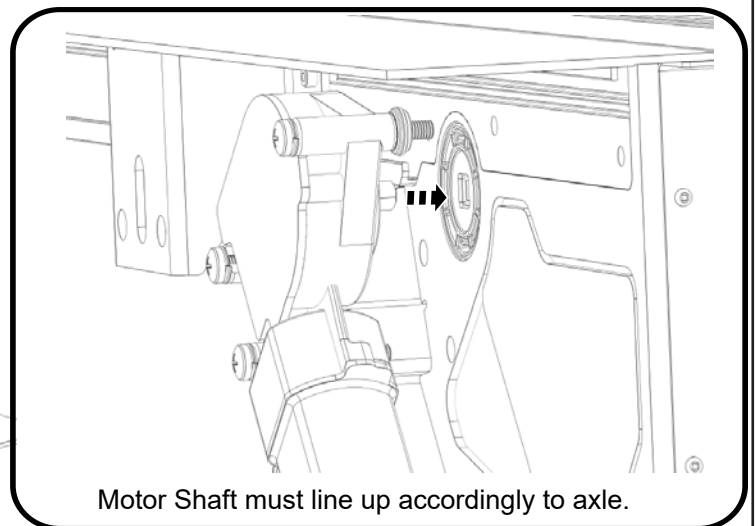
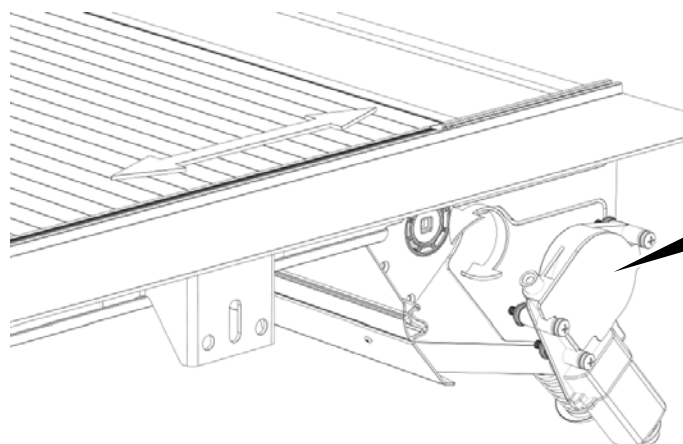

Fasten all 3 screws to 2nm torque. Over tensioning will cause operating issue's.

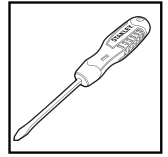
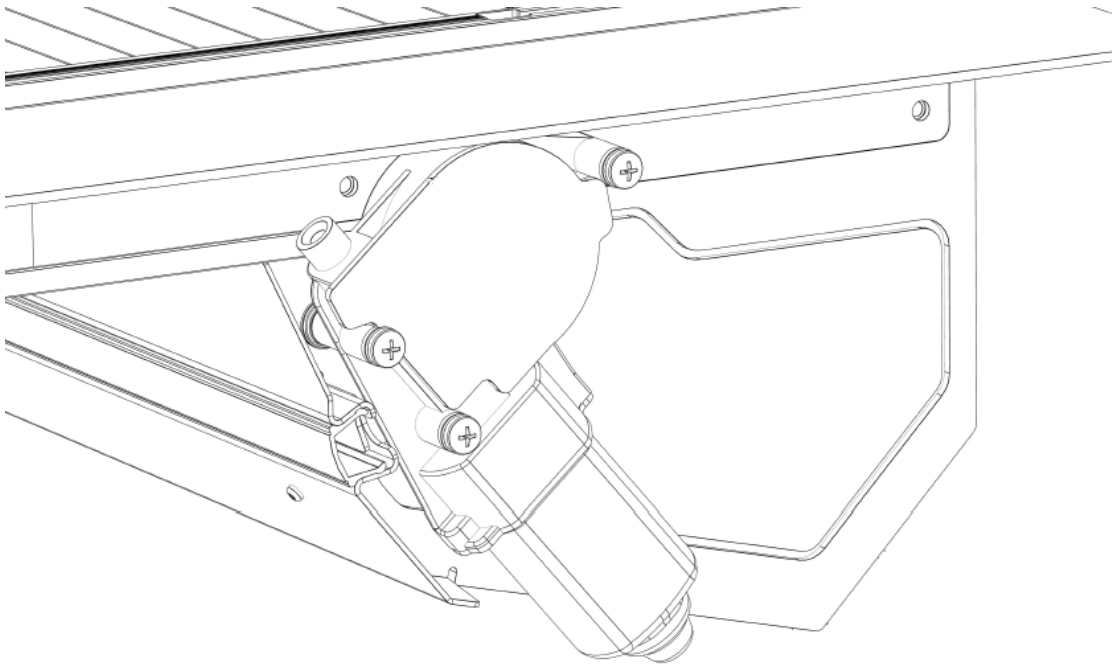

**Motor is to sit level.**

Any obstructions between motor and canister may cause operating issues.

Apply D-sponge foam tape to side rail as indicated. NOTE: Join foam firmly to the pre-fitted foam of the canister. Carefully trim excess off & discard as indicated. Repeat on the other side.

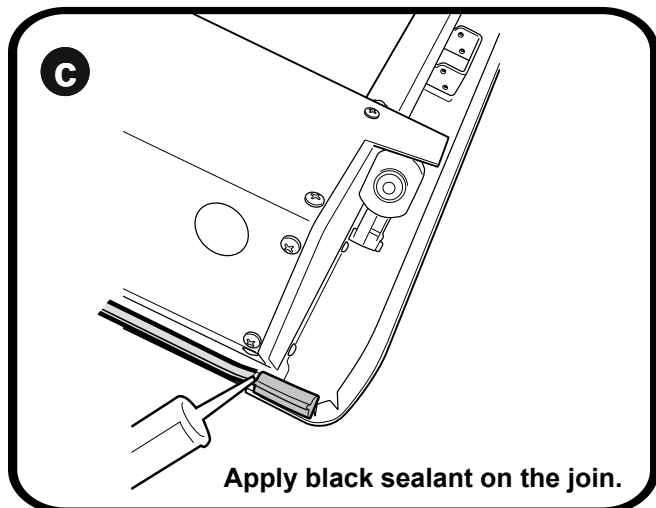
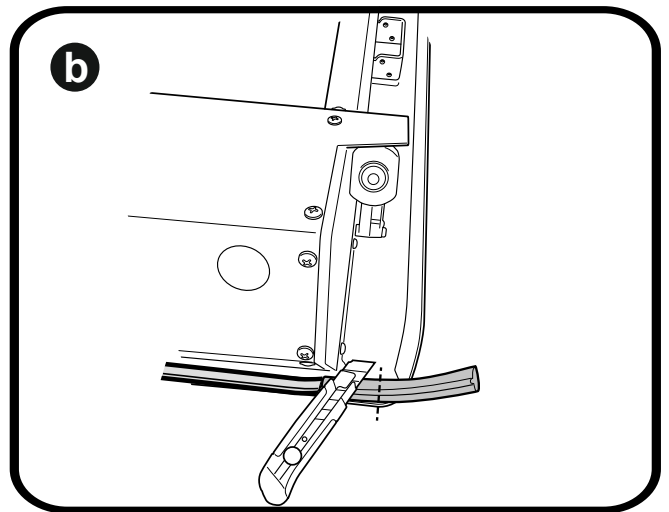
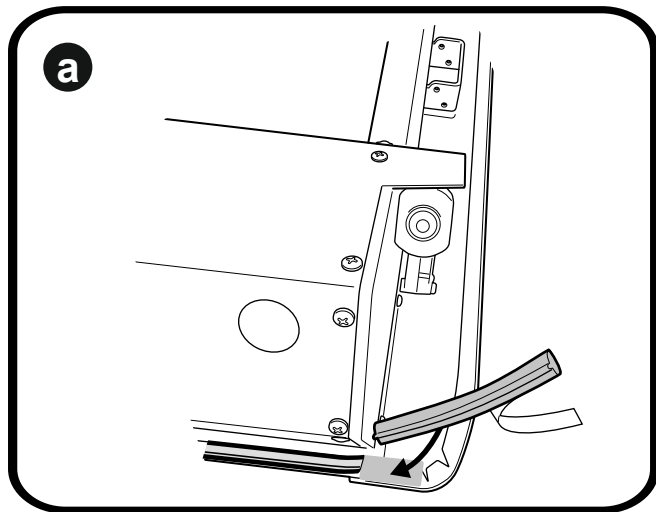

Apply black sealant on the join.

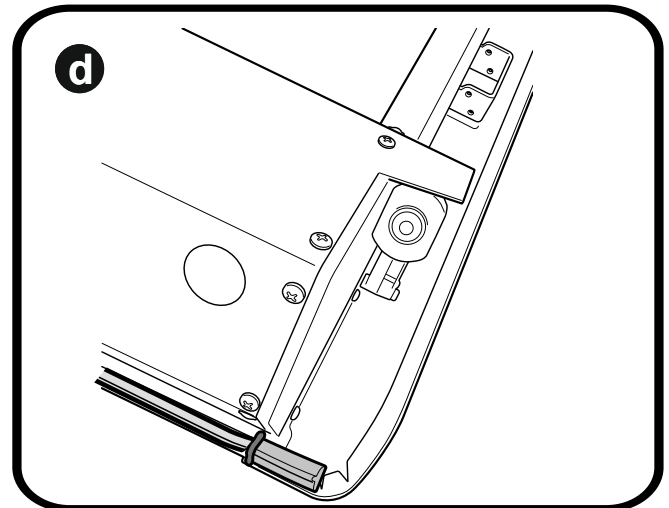

Carefully bring down the assembled unit .

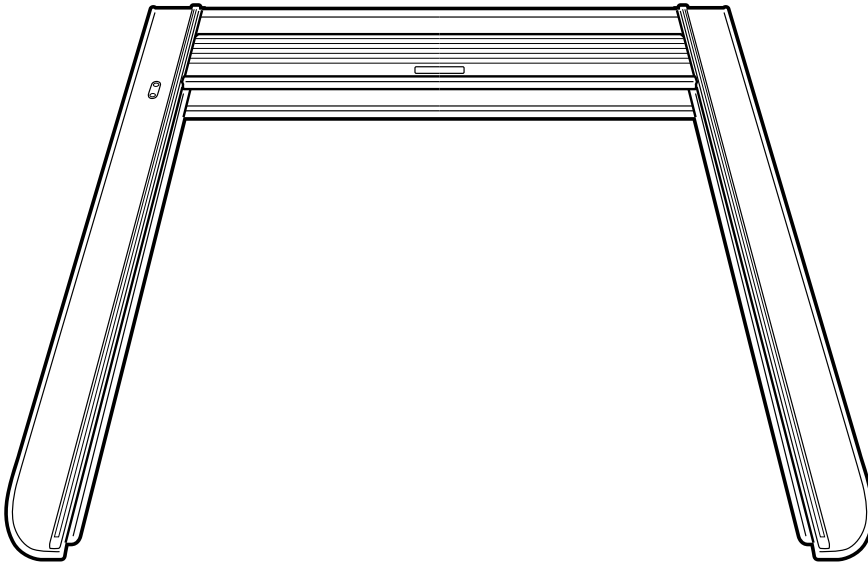

Insert side end caps to the top cover.

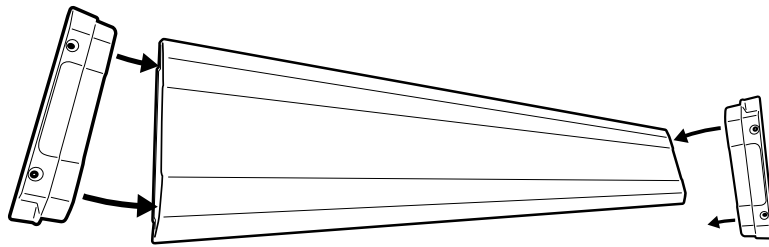

Place & Align top cover over the canister and side rails.

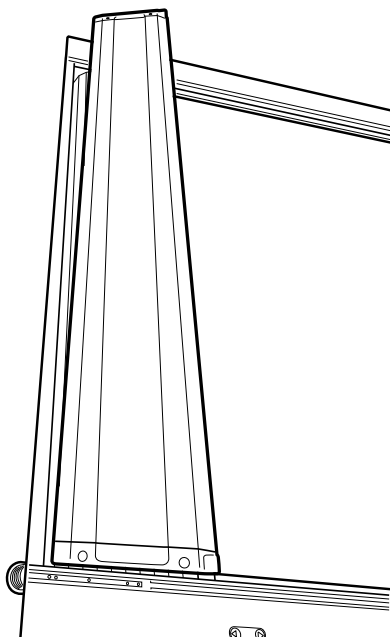

Using countersunk screws provided, line up end cap holes to the threads on the side rail. Fasten to 3nm torque. Repeat to the other side.

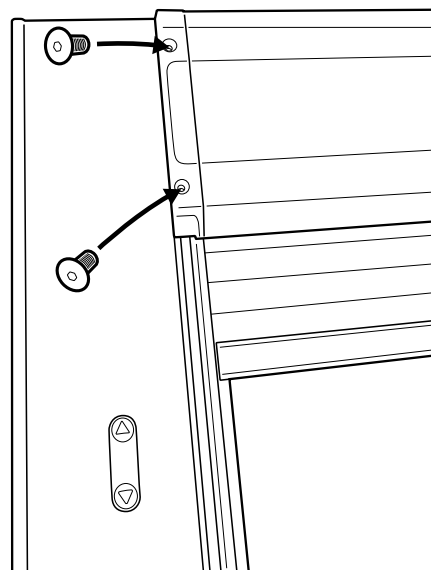

Seal any exposed gaps or holes on the front panel of the Ute bed with sealant.

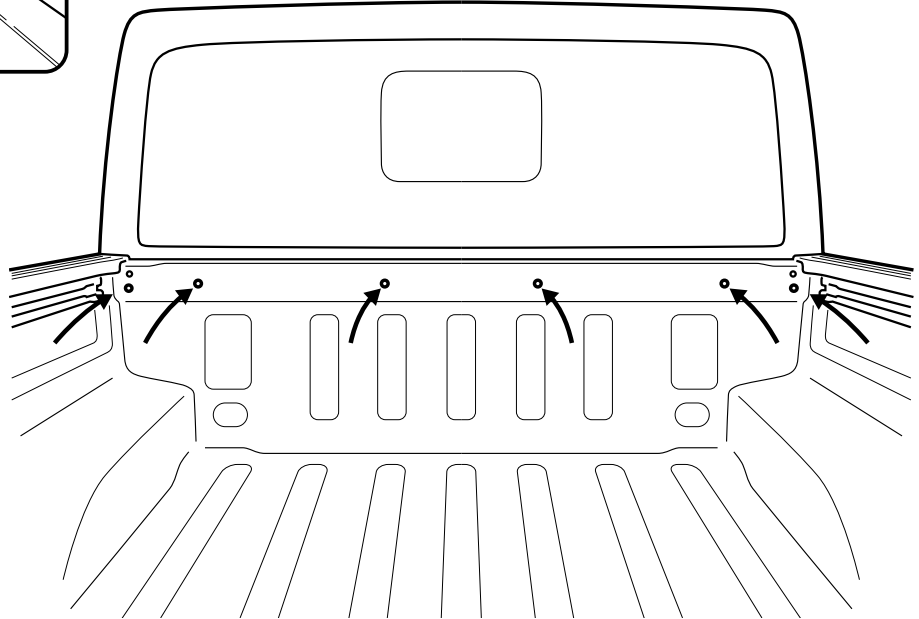
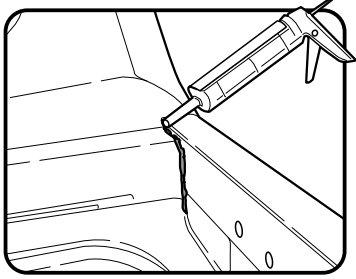

Place the Roll-R-Cover unit on to Ute bed.

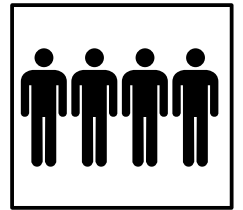

4 People  
Recommended for lift

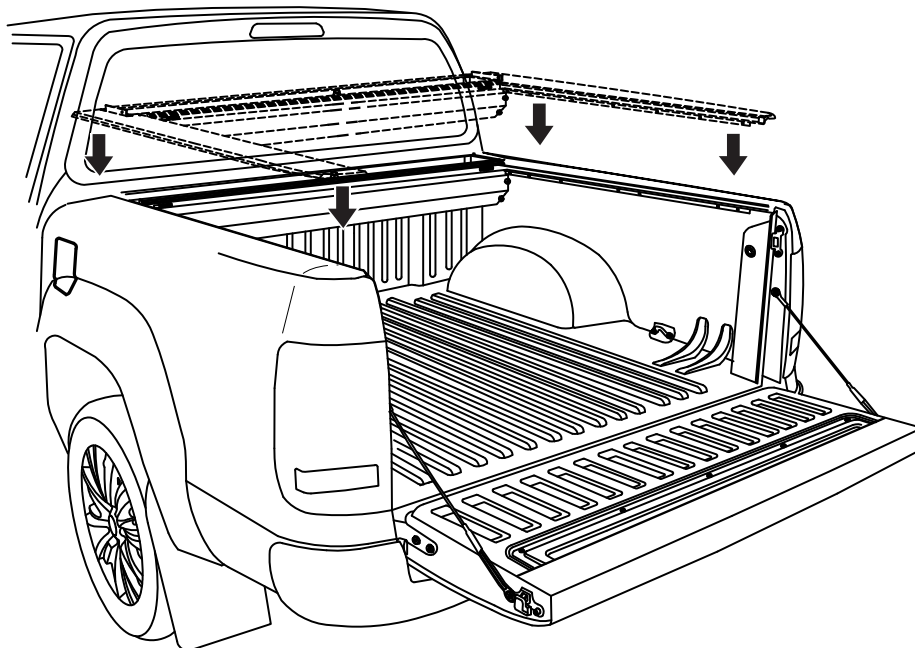

With care, pull out any side rubber that has folded under the side rail.

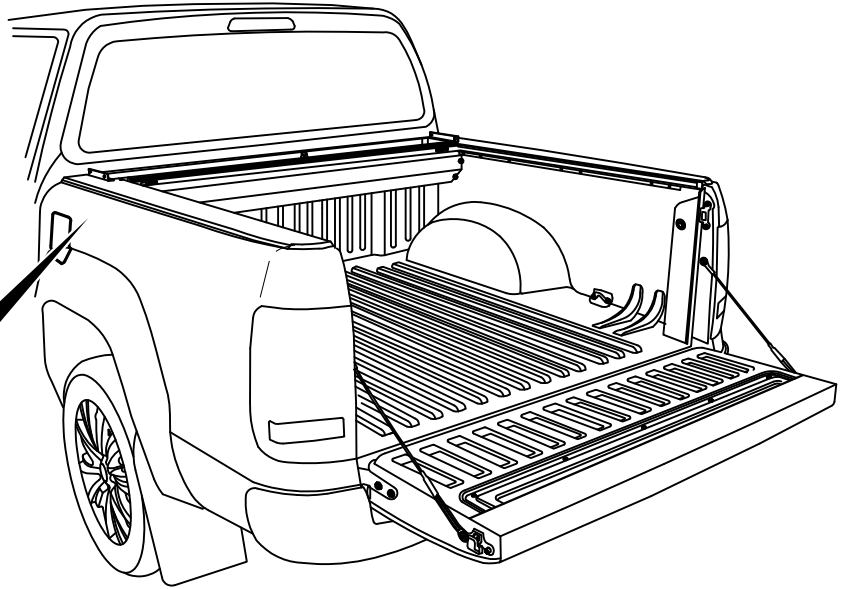
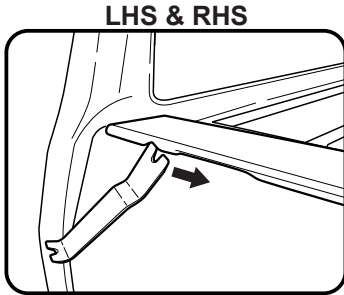

With the tailgate up (Closed position), Pull left & right hand side rails towards the tailgate, stopping short by 5mm between tailgate and side-rail endcap.

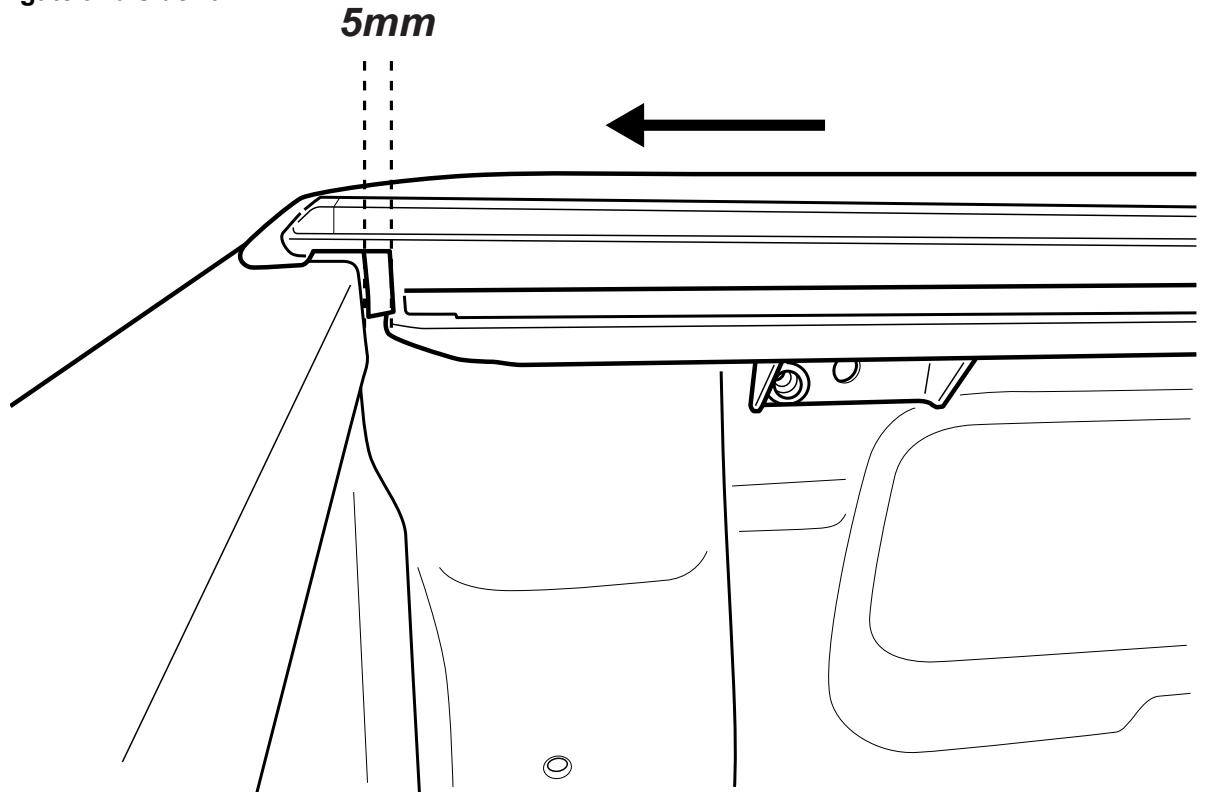

Foam compressed to 5mm when tailgate is closed.



Gap between tailgate and side-rail end cap to be 5mm.



Foam compressed to 5mm when tailgate is closed.

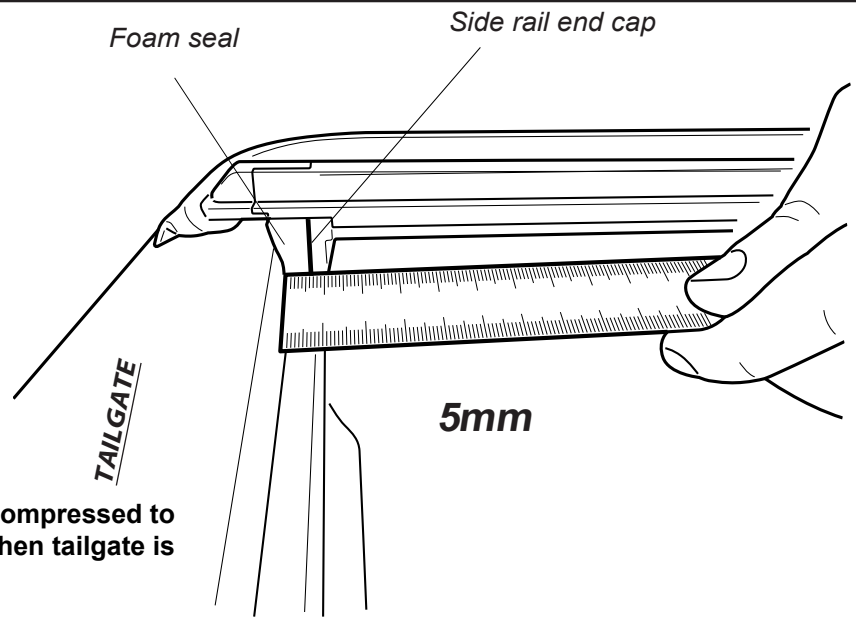

Position clamp behind the inner top lip of the bed rail and the center elongated hole of the side rail mounting brackets. Repeat to all 6 positions.

Ensure the M8 nut is in the indicated slot of the clamp

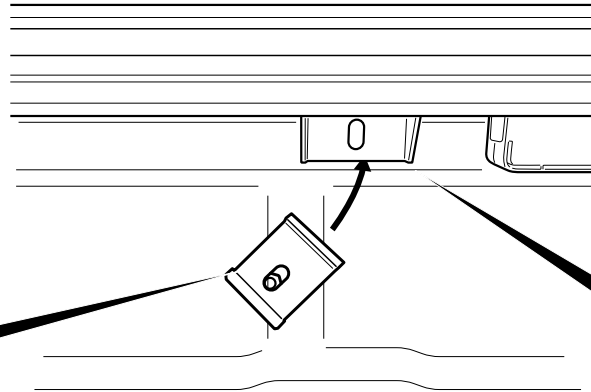
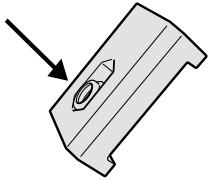

Fasten clamp loosely into position using M8 washer, M8 spring washer and M8 x 35mm bolt.

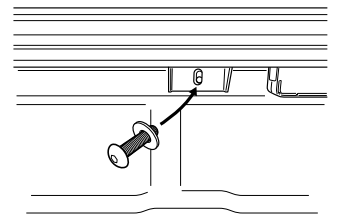

1. Apply pressure on side rails.
2. Lift clamp all the way up, then tighten clamp in the order indicated.

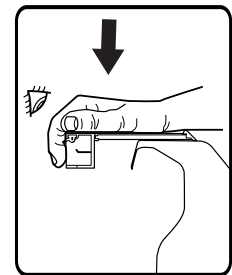
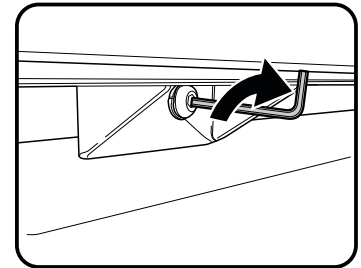
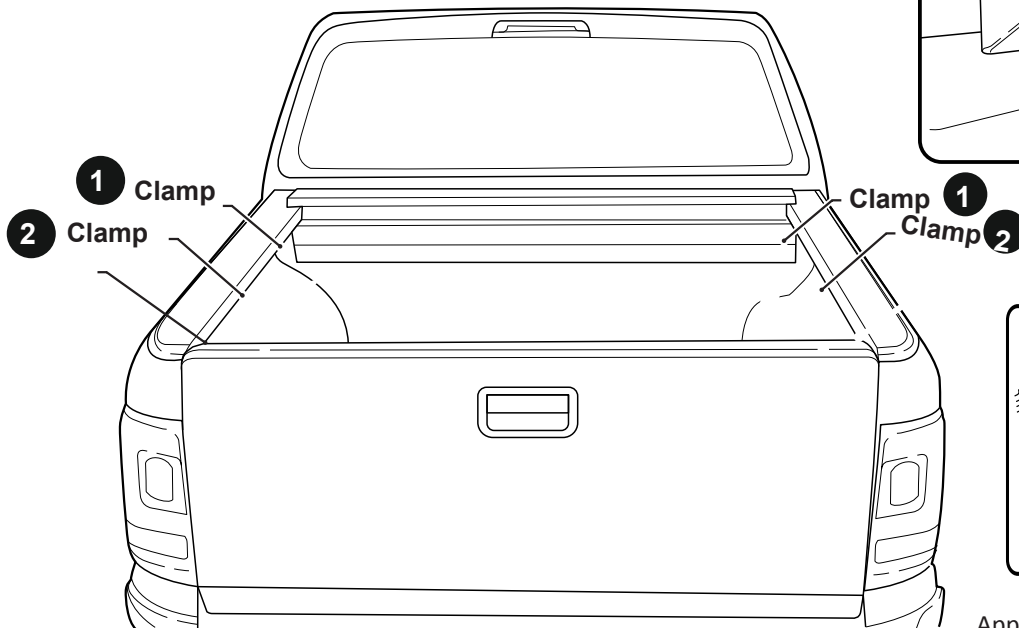

Apply slight pressure then tighten Bolts

With the tailgate closed, hold the side rail up, to allow the side rail seal to clear the tailgate by 1mm.

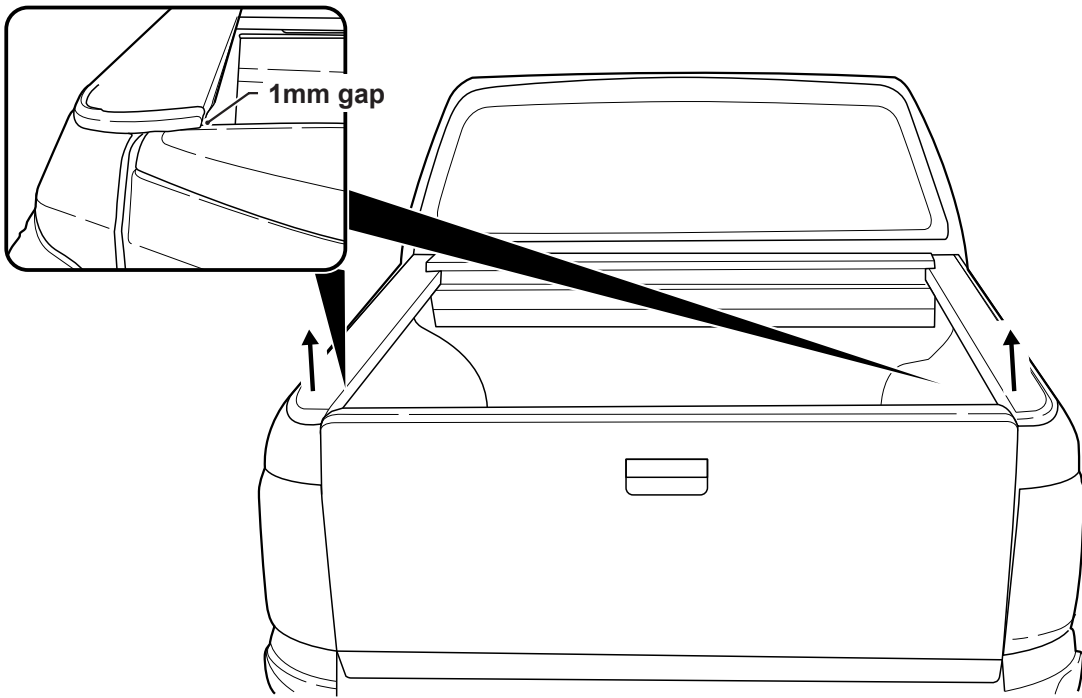

With the side rail held in position from previous step, fasten the clamps on each of the rear clamp brackets.

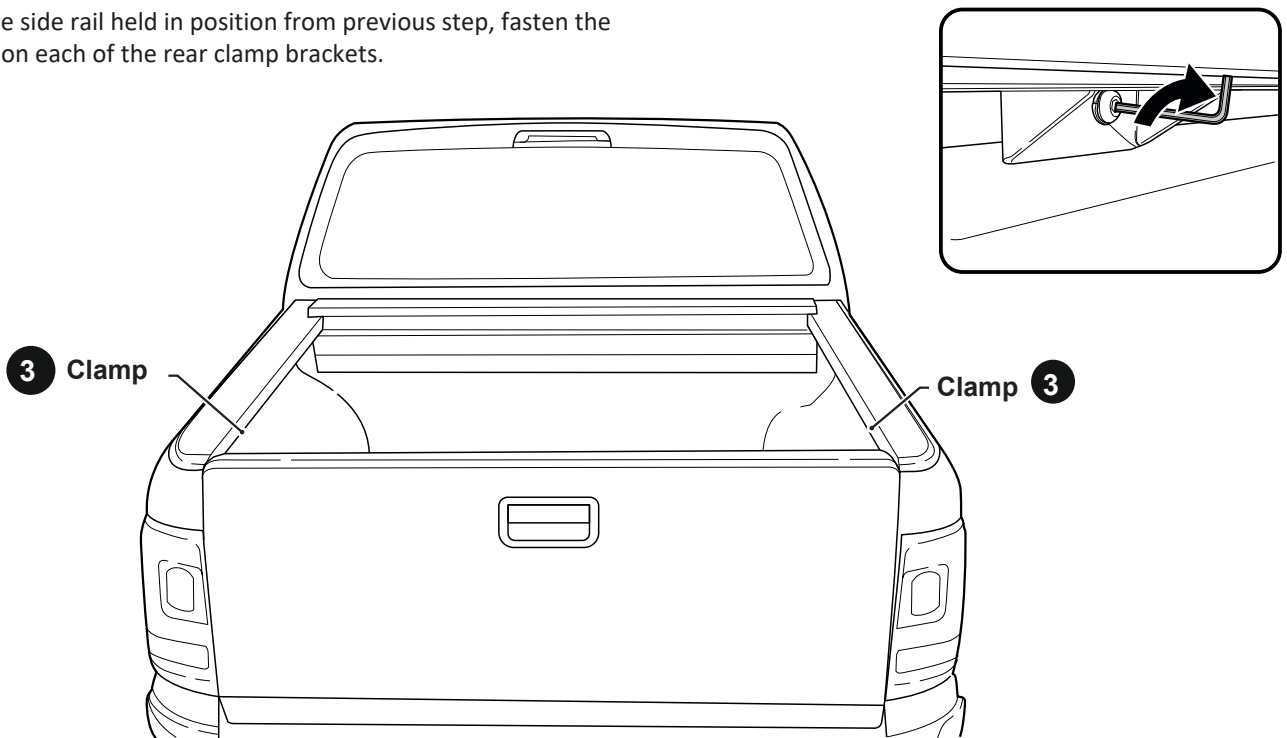

Install front drain pipes through pre-drilled holes of the canister. ( RHS/LHS)



Note: With care push tube in.  
Taking care pull the tube back  
so it seals correctly against  
the front panel of the tub.

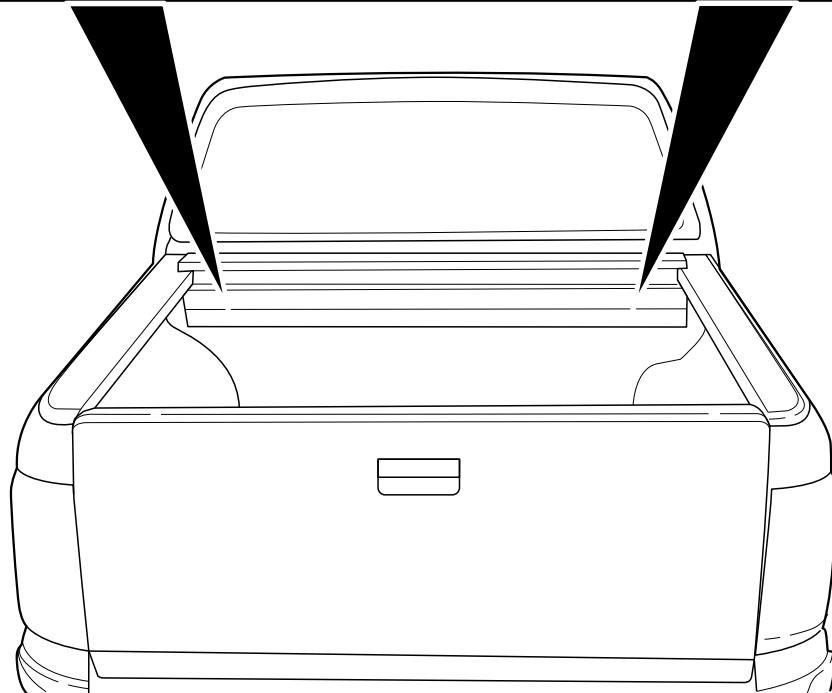
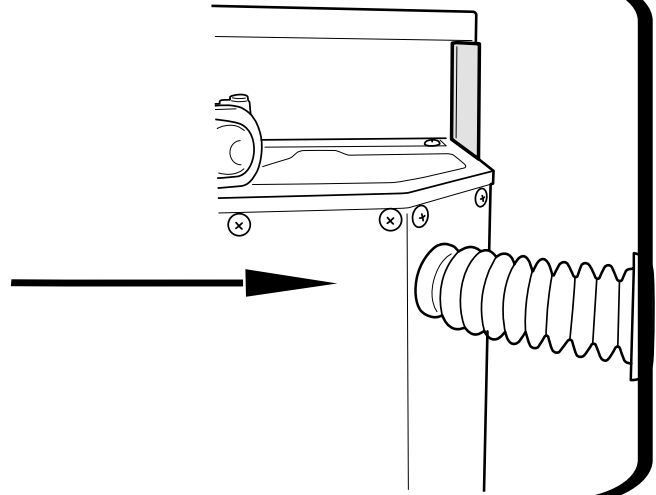
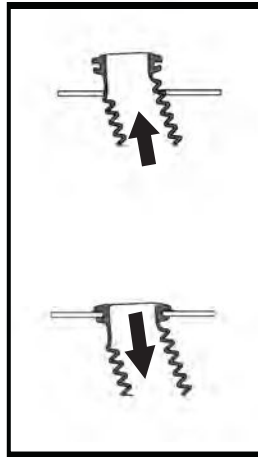

- a. Connect Battery loom S2.75 to Receiver loom.
- b. **Carefully** connect CI-Loom-short to Receiver loom.



Align connectors  
carefully to avoid  
pushing pins out.

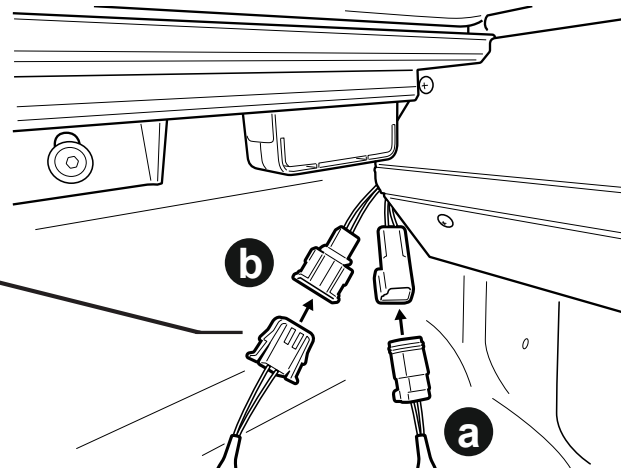

### Operating instructions:

Press unlock on vehicle key fob to activate controller.

When vehicle is unlocked the side rail sensor buttons will be active to control.

When vehicle is locked the side rail sensor buttons will be inactive.

### Using factory key fob to operate:

Pressing unlock twice on the factory key fob within 4 seconds, will activate the roll r cover to open.

Pressing lock twice on the factory key fob within 4 seconds, will activate the roll r cover to close.



### Vehicle proximity:

Tapping the proximity twice to open or lock the car door will act exactly the same way as the key fob being pressed twice.

Touch & let go to  
open, touch & let  
go again to pause.

Touch & let go  
to close, touch  
& let go again  
to pause.

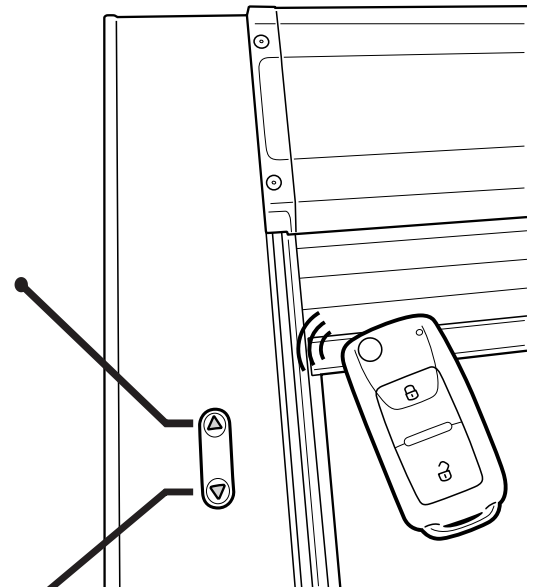

NOTE: 1. To wear in the Roll R Cover please fully open & close the cover approximately 15 times after install is complete.

2. Set your vehicle locking system to unlock all doors with one press of the factory remote unlock button. This setting can be found in your vehicle settings.