



WWW.HSPUTELIDS.COM

1300 441 498

Part No: H18

Fitting Time: 45mins



TOYOTA HILUX

HSP TAIL LOCK

FITTING INSTRUCTIONS

—General Notes

- Read through the fitting instructions prior to installation of accessory.
- Ensure all Recyclable components, packaging are discarded & recycled following local recycling regulations.
- Safely store and protect and removed vehicle components.

—Safety Notes

- Check that all work practices comply with safety standards.
- Please wear appropriate clothing and use safety equipment.

- WARNING Failure to install product not in accordance with manufacturers instructions may result in fire.

- WARNING Failure to install product not in accordance with manufacturers instructions may void warranty.
- WARNING We recommend disconnecting the battery terminals before commencing install of tail lock. Please ensure you have your vehicle book with radio/infotainment codes on the unlikely chance these need to be re-entered in.

—Fitting Time



45mins

—PARTS SUPPLIED

Part Description	Part Number	Quality/ Length	CHECK LIST
TAIL LOCK ASSEMBLY			
Main Brackets & ACT-01	H18-A	1	
Wiring	CL-LOOM-LONG	1	
Patch Wiring	X-PATCH	1	
FASTAENERS			
M6 Shoulder Bolt	2	1	
OTHER			
Cable Ties		5	
Fitting Instruction		1	

— STEP 1 —

Note down all clock and radio settings

Disconnect the negative terminal of the battery (1) in the engine bay.

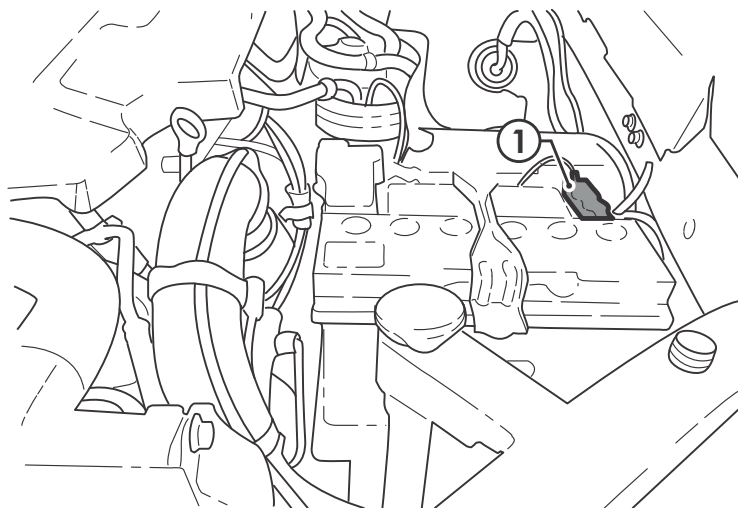

— STEP 2 —

Remove access panel on tailgate.

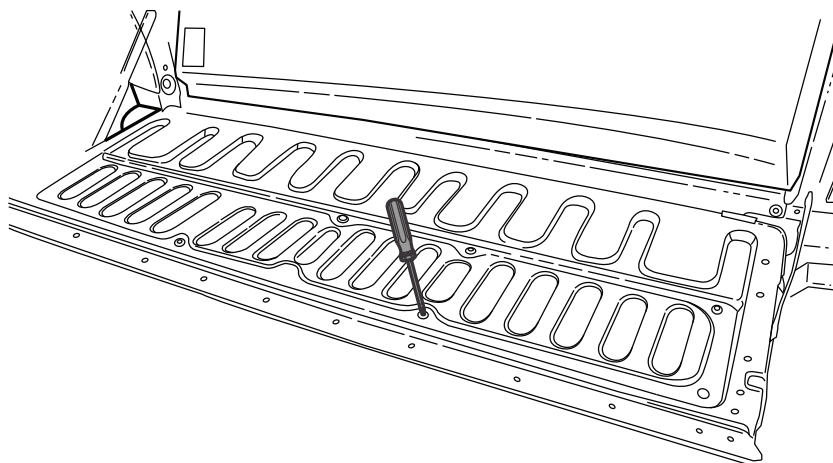

— STEP 3 —

Remove locking arms (1) from bracket.

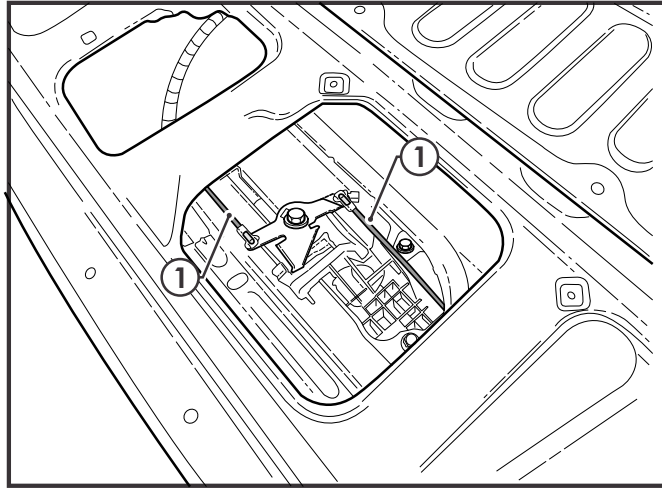

— STEP 4 —

Remove vehicle lock bracket by unfastening the bolt.

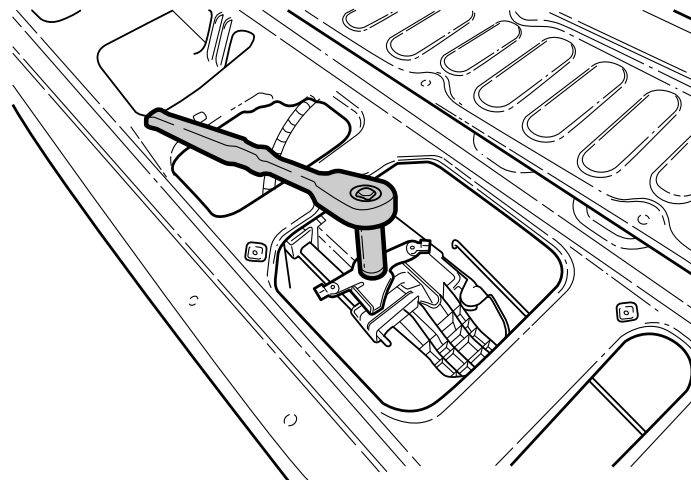

— STEP 5 —

Ensure the vehicle lock spring (1) is in place as shown.

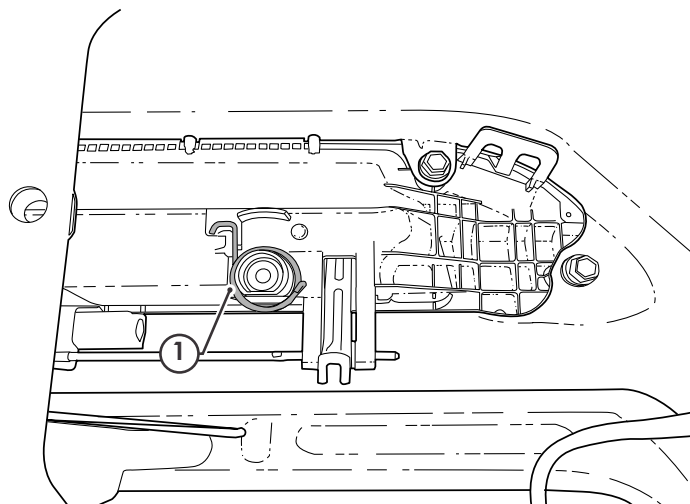

— STEP 6 —

Put the lower bracket (1) (labelled "H18a") in place over the spring.

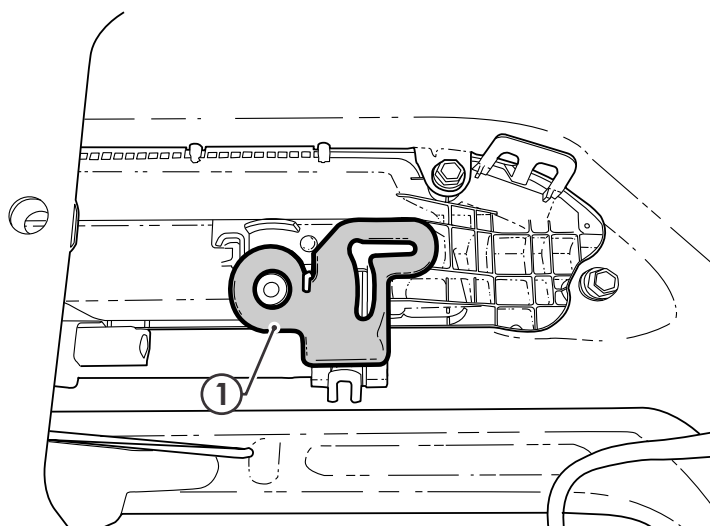

— STEP 7 —

Put the actuator and the upper bracket (1) in place, ensuring the actuator pin (2) drops through the slot in the lower bracket (3).

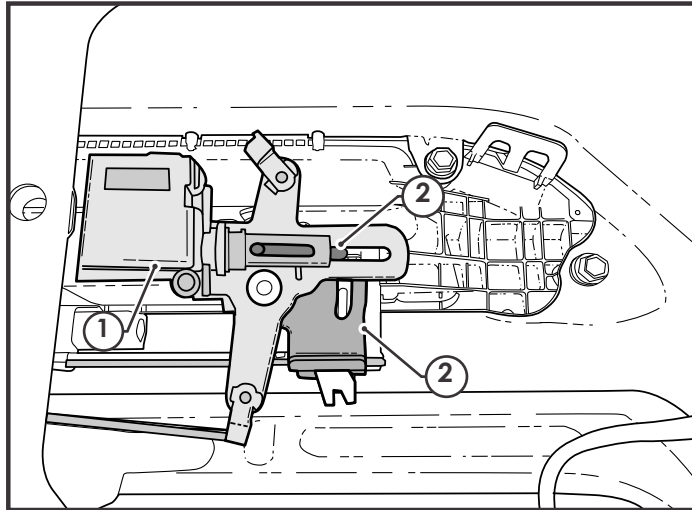

— STEP 8 —

Secure the supplied actuator and bracket set (1) in place with the supplied shoulder bolt (2).

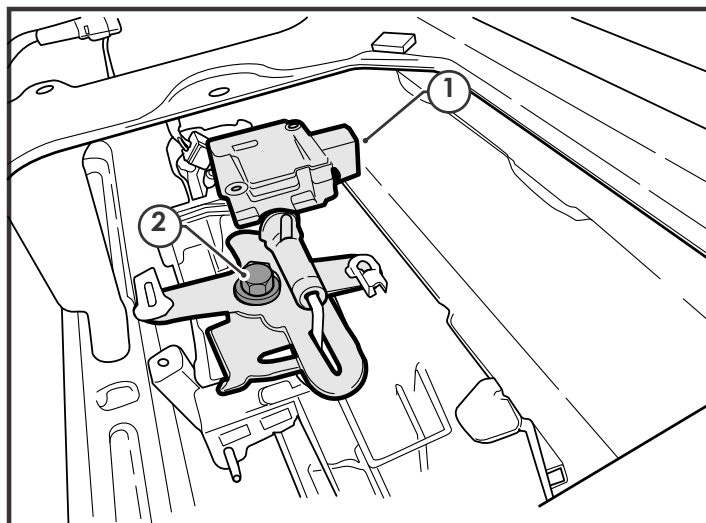

— STEP 9 —

Re-attach the lock arms (1) to the bracket using the clips (2).

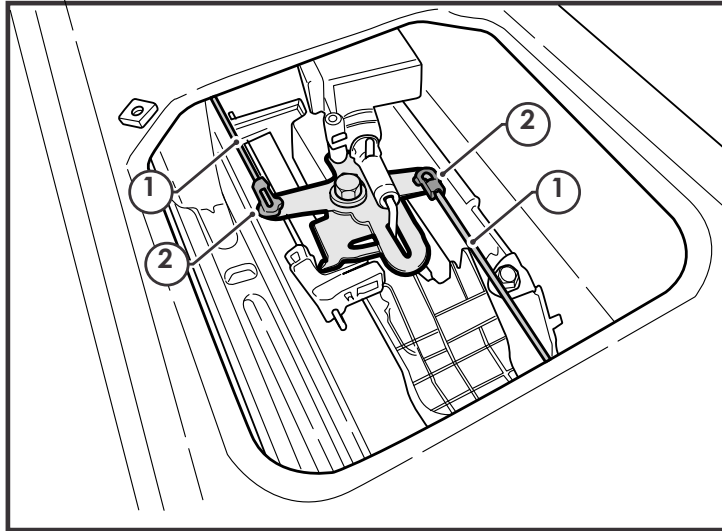

— STEP 10 —

Connect the black 2-way connector (1) on the wiring harness to the actuator (2).

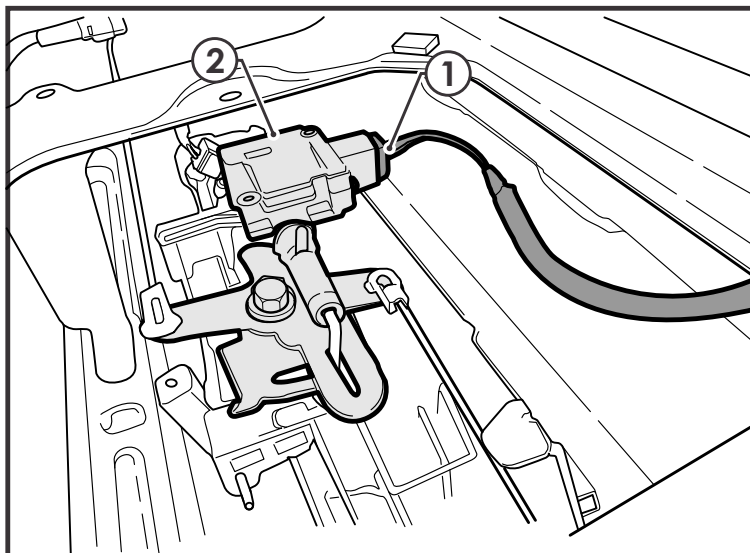

STEP 11

Route the actuator wiring harness (1) out of the tailgate and underneath the vehicle following the existing vehicle harness.

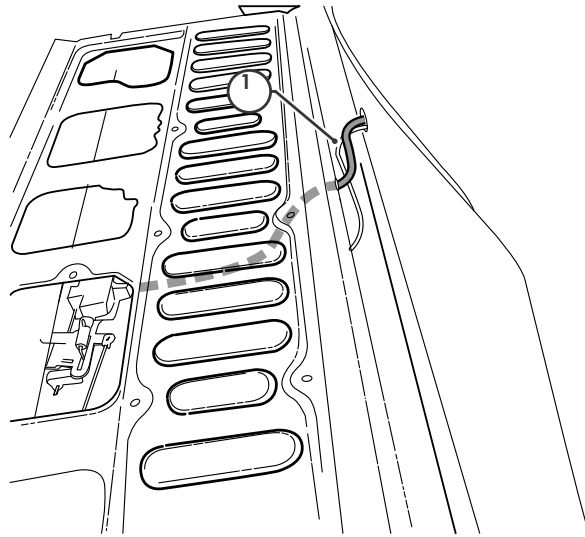

STEP 12

- 1) Route the CL - Loom-long harness along the LHS chassis rail to the grommet underneath the LHS front seat.
- 2) Secure the wiring every 400mm with the cable ties provided.
- 3) Make a slit in the grommet, pass the actuator wiring harness through the grommet (1) and using silicon, reseal the slit.

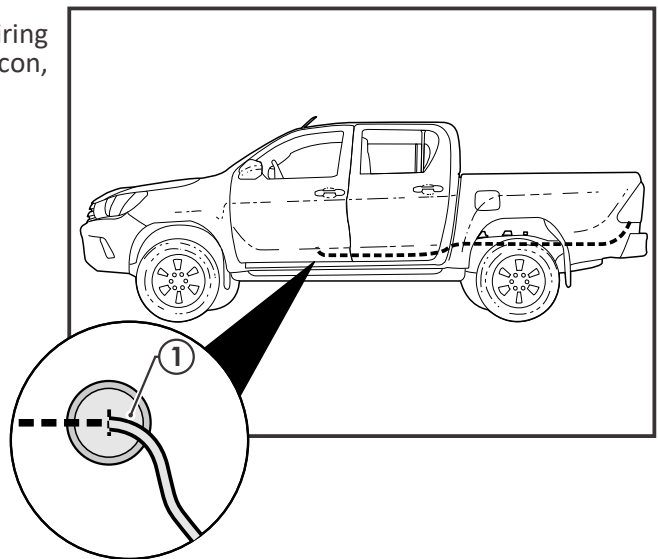

STEP 13

At the front passenger side foot well area: Remove front passenger scuff plate (1)

Remove the kick panel trim nut (2).

Remove the kick panel (3).

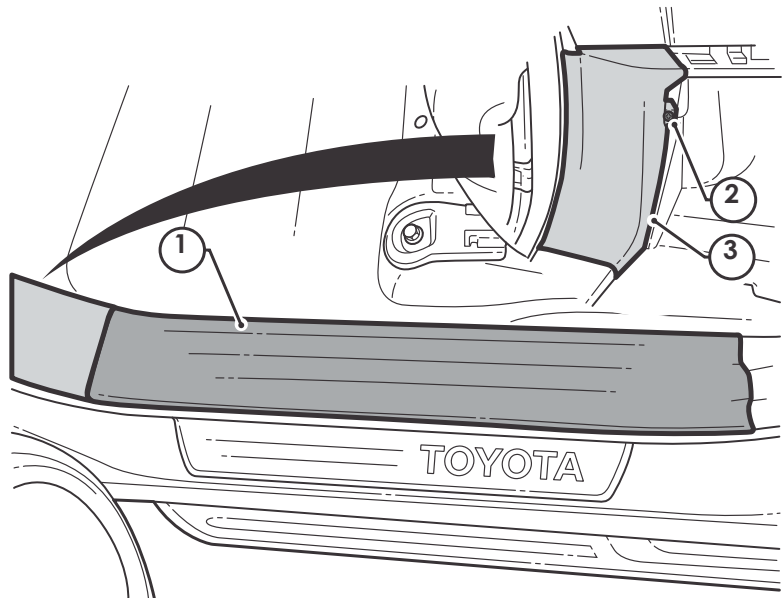

STEP 14

Continue routing the actuator wiring harness (1) through the grommet, along the door sill up to the LHS kick panel, following the existing vehicle harness.

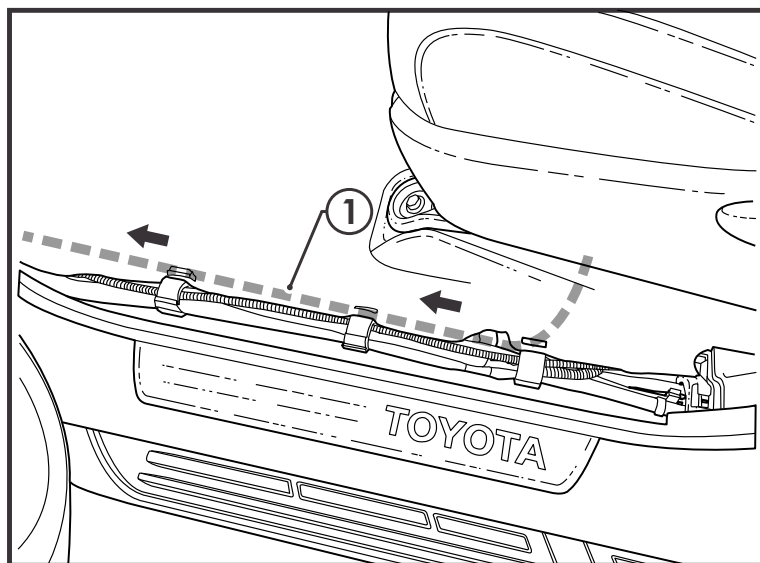

STEP 15

Locate and disconnect the 20-way hybrid junction connector (1) in the passenger side kick panel area.

Identify the two Lock/Unlock terminal wires as shown:

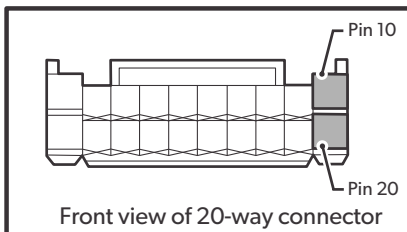

Connector Pin 10: Lock / Black Wire
Connector Pin 20: Unlock / White Wire

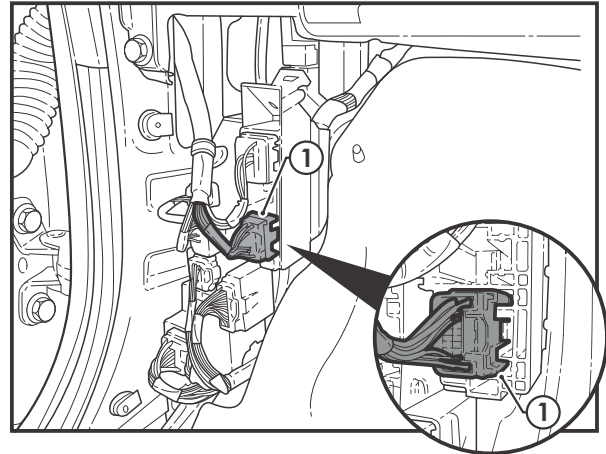

STEP 16

Using a precision screw driver, unclip the connector secondary lock (1). Carefully remove the two Lock/Unlock wires from the rear of the connector using a precision screw driver.

House the Blue and Red lamp vehicle x-patch harness terminals (2) into the rear of the connector cavities in the positions show:

Red Wire Upper Cavity (3)
Blue Wire Lower Cavity (4).

Push the 20-way connector secondary lock (1) into place to retain terminals.

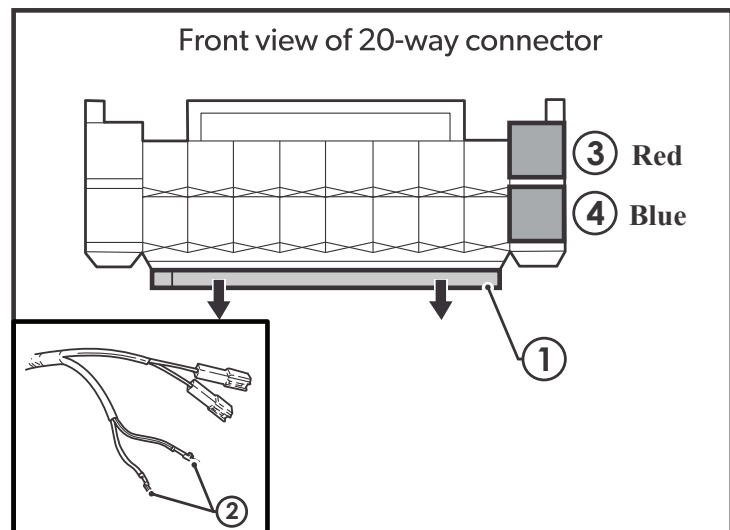

STEP 17

House the lock/unlock wiring terminals, previously removed from the vehicle harness (1) i supplied 2-way male connector as shown, now Connect the actuator wiring harness to the vehicle patch harness 2-way connector (3).

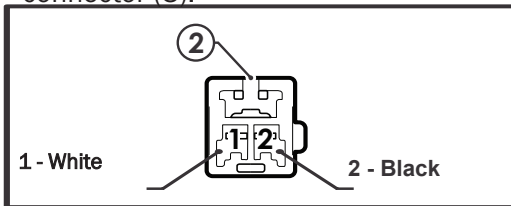

Rear view of 2-way connector

Check the wiring harness and vehicle patch harness are securely attached to the main vehicle harnesses.

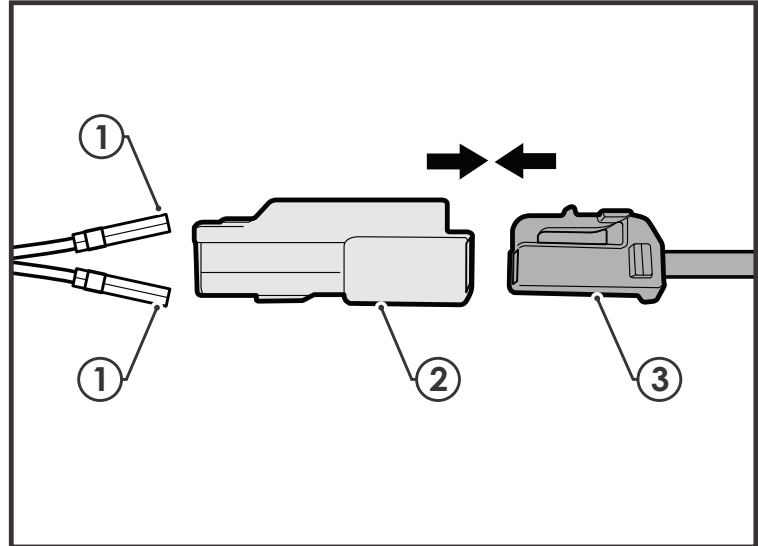

STEP 18

Connect X-PATCH loom to CL-LOOM-LONG

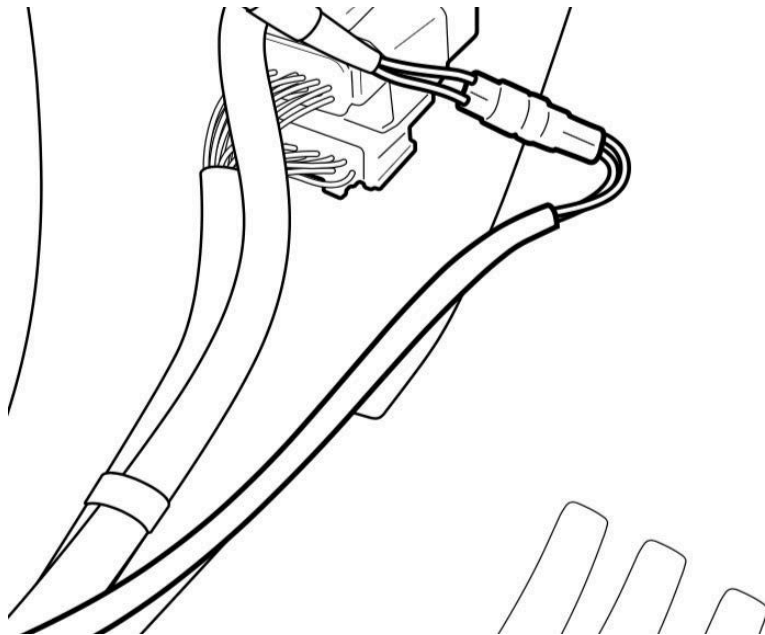

— STEP 19 —

Place and fasten tail gate cover.

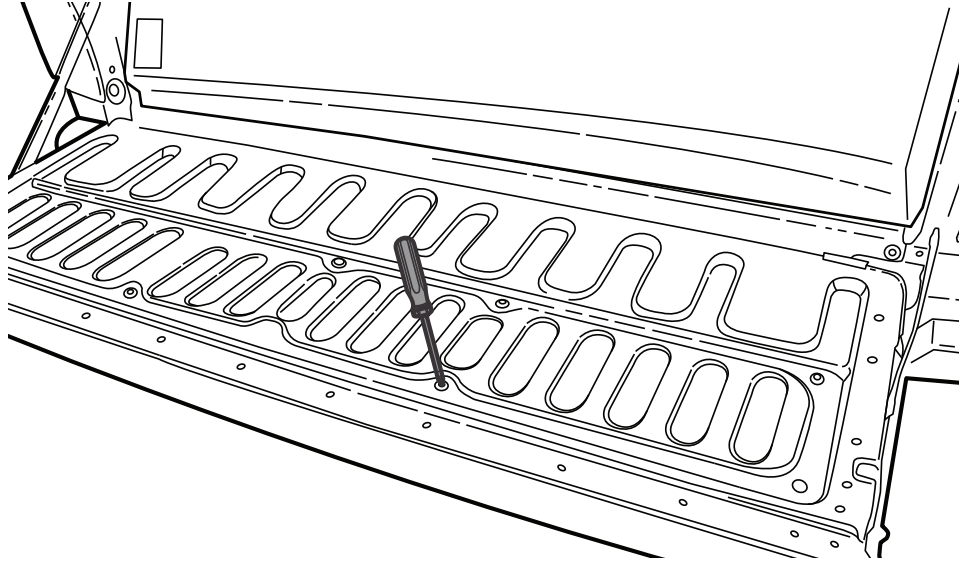

— FITTING COMPLETE —