



www.Hsputelids.com
1300 441 498
Part No: DM12 Fitting
Time: 30 mins



ISUZU DMAX (MY21) 07/2020 +

HSP TAIL ASSIST

FITTING INSTRUCTIONS

—GENERAL NOTES

- Read through the fitting instructions prior to installation of accessory.
- Ensure all recyclable components and packaging are discarded and recycled following local recycling regulations.
- Safely store and protect any removed vehicle components.

—SAFETY NOTES

- Check that all work practices comply with safety standards.
- Please wear appropriate clothing and use safety equipment.

—FITTING TIME



30 mins

—PARTS SUPPLIED

| <u>PART NUMBER</u> | <u>PART DESCRIPTION</u> | <u>QUANTITY</u> | <u>CHECK</u> |
|--------------------|----------------------------|-----------------|--------------|
| KSD-SPEC-2 | Dampener strut | 1 | |
| TRS-SPEC-2 | Traction strut | 1 | |
| TA-23 | Low hex head bolt | 1 | |
| TA-24 | Tailgate M8 ball bolt | 1 | |
| TA-10RH | Tailgate mount R/H | 1 | |
| TA-15 | M8 Shoulder bolt-tub mount | 2 | |
| TA-16 | Strut locking bolt | 2 | |
| CB1 | Tailgate cable | 2 | |
| | <u>OTHER</u> | | |
| | Alcohol wipe | 1 | |
| T882 | Cable stop | 2 | |
| | | | |

—STEP 1—

Open tailgate. Then remove the indicated rubber stops and discard.

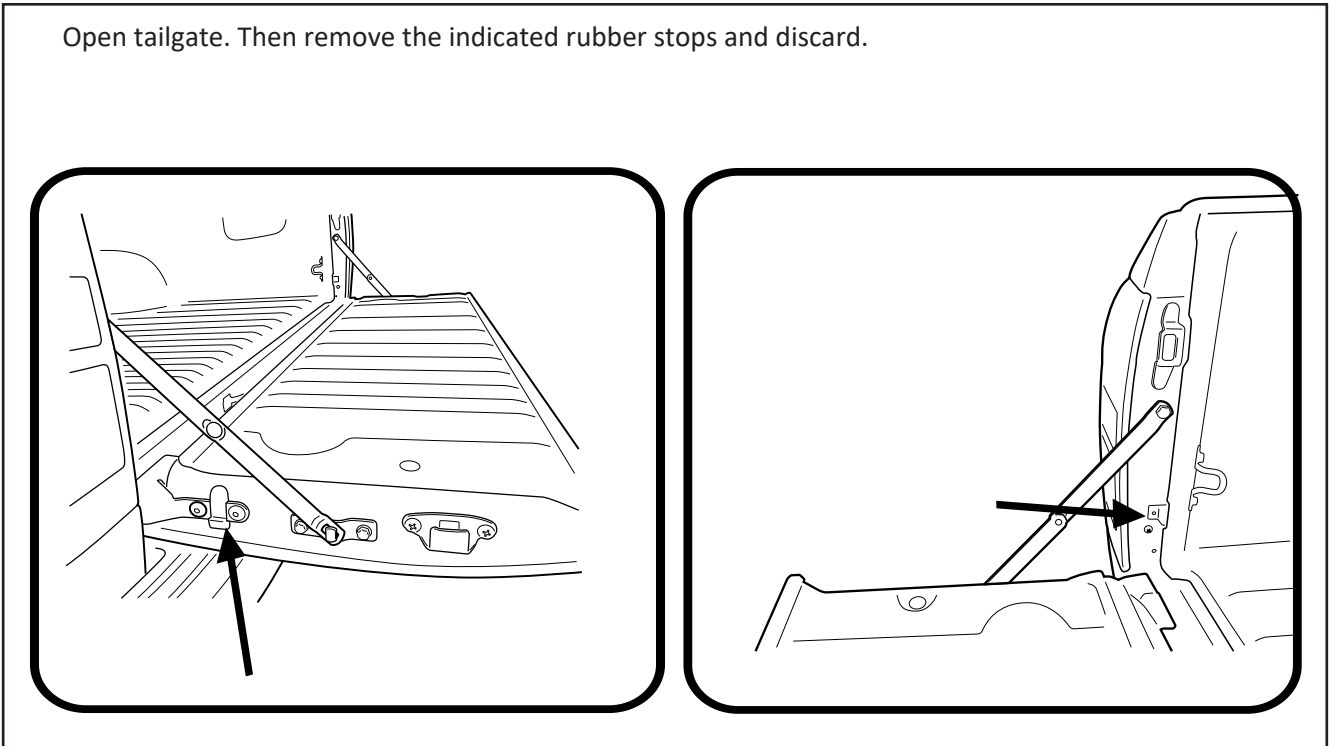

—STEP 2—

1. If the ute is fitted with a steel hinge, it will need to be removed and discarded.
2. Discard the shoulder bolt & washers, when removing the steel hinge.

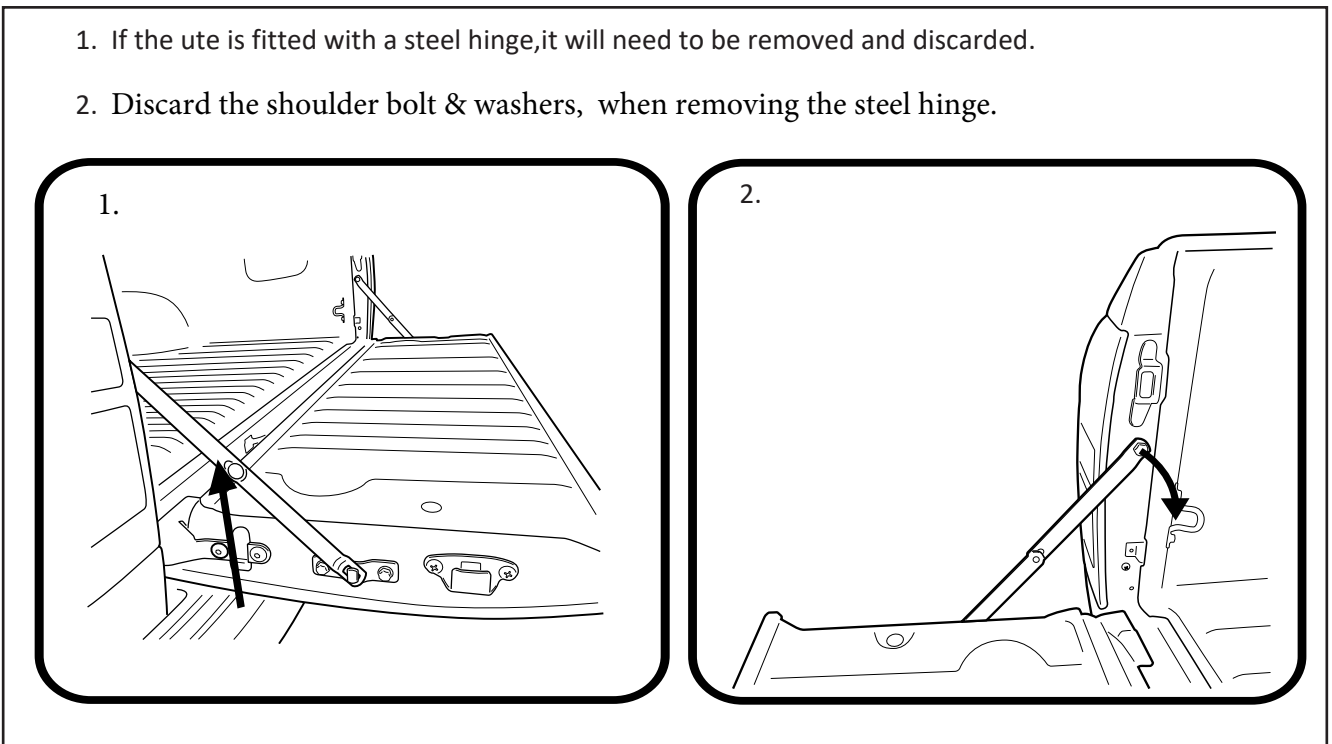

— STEP 3 —

1. Feed part number(TA-15) M8 shoulder bolt trough strap (Cb1) . Now fasten to same location to where the steel bracket shoulder bolt came out of.
2. Hook the slotted end of the cable to the tailgate bracket as indicated.

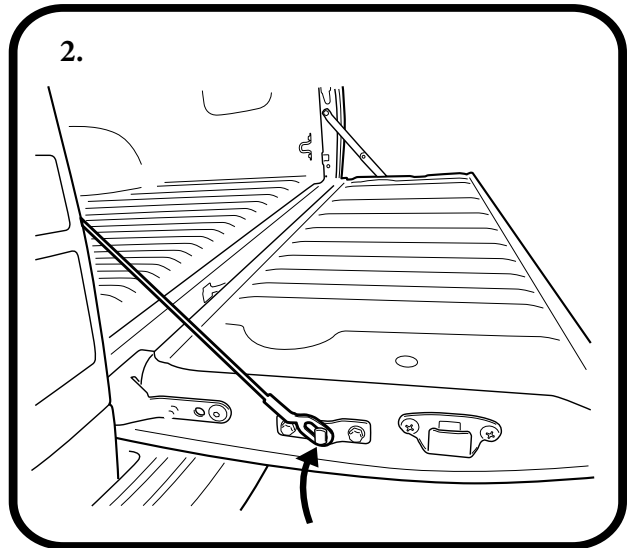
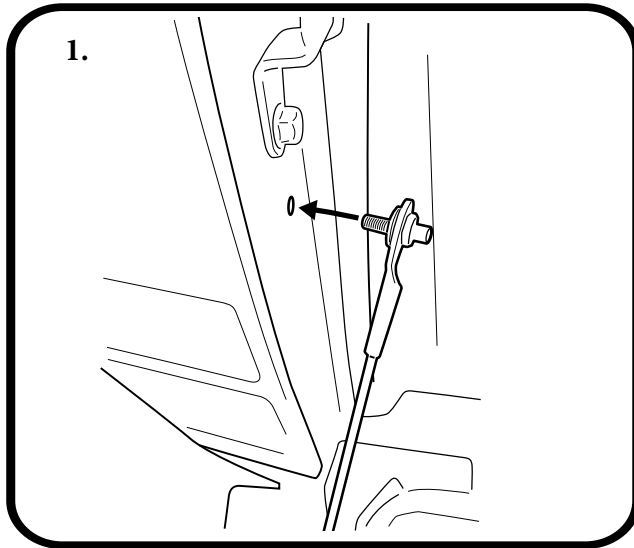

Now repeat the step on the driver side.

— STEP 4 —

Fit dampening strut, part number KSD-spec-2 cylinder end to the Shoulder of (TA-15) followed by strut locking bolt (TA-16) . **NOTE:** TA-16 Should be tighten to 2nm torque, **Do not use power tools** for this step. (small amount of Loctite is recommended)

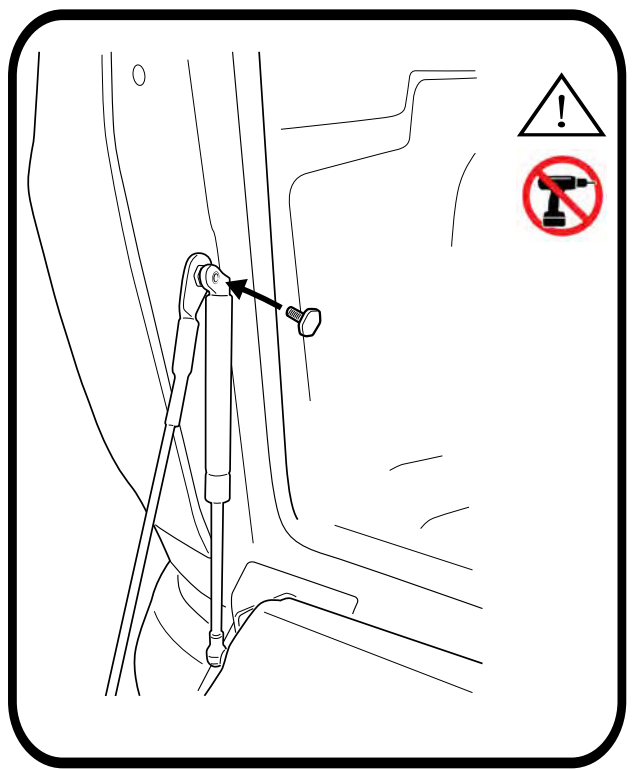
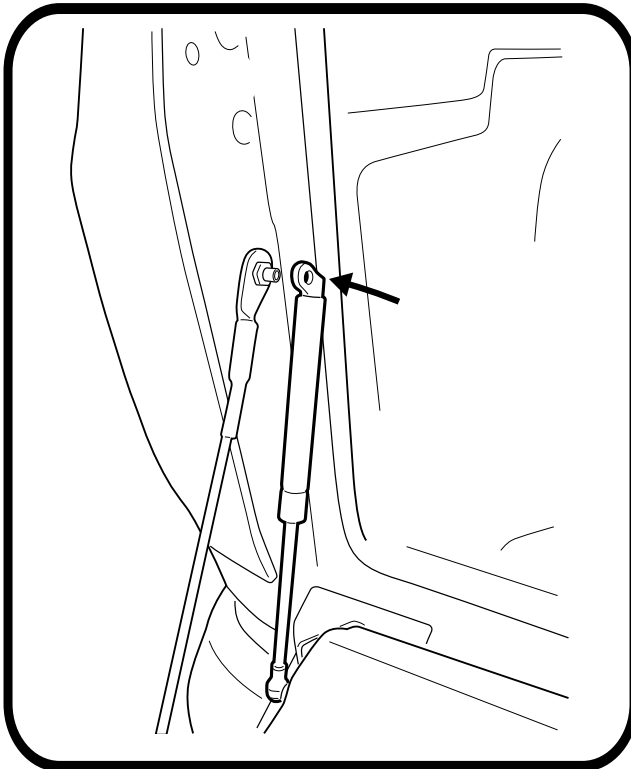

—STEP 5—



Passenger side

1. Remove indicated bolt, and discard.
2. Feed M8 ball bolt (TA-24) to indicated location, tighten to 4nm torque.

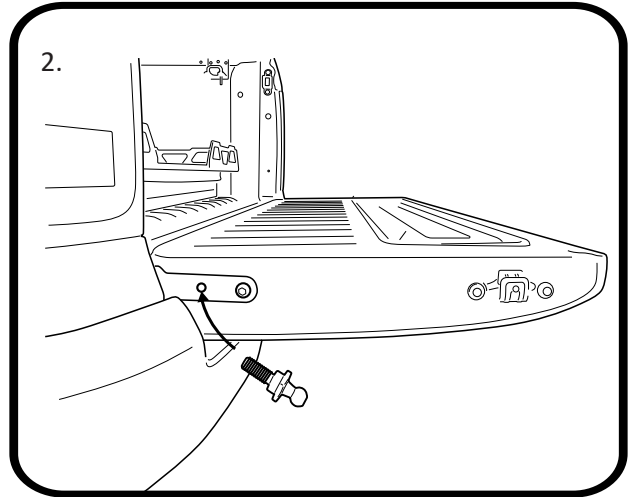
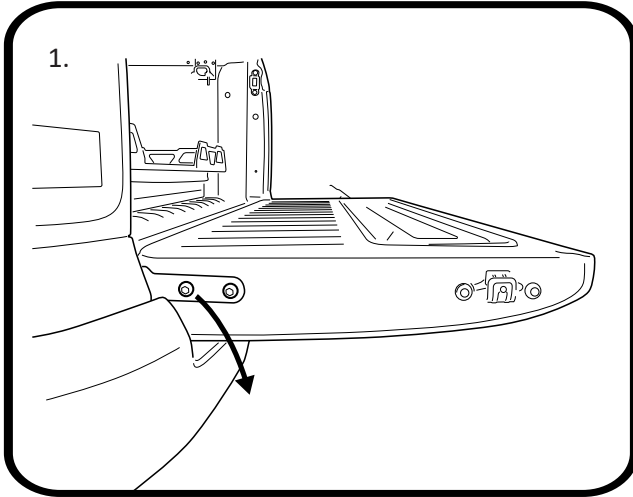

—STEP 6—



Passanger Side.

1. Remove indicated bolt, and discard.
2. Feed low head M8 bolt (TA-23) to indicated location, tighten to 4nm torque.

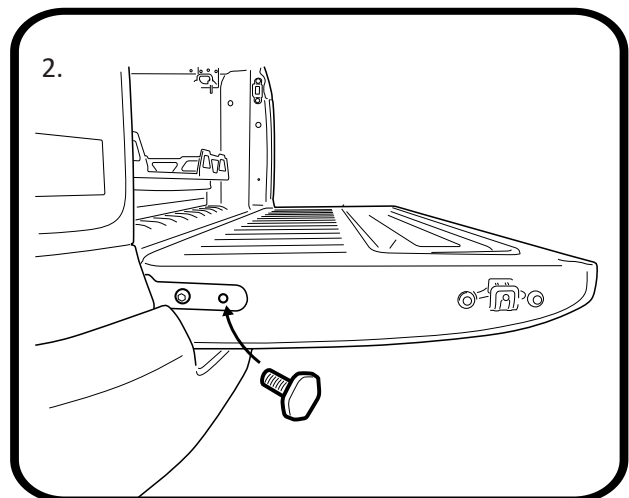
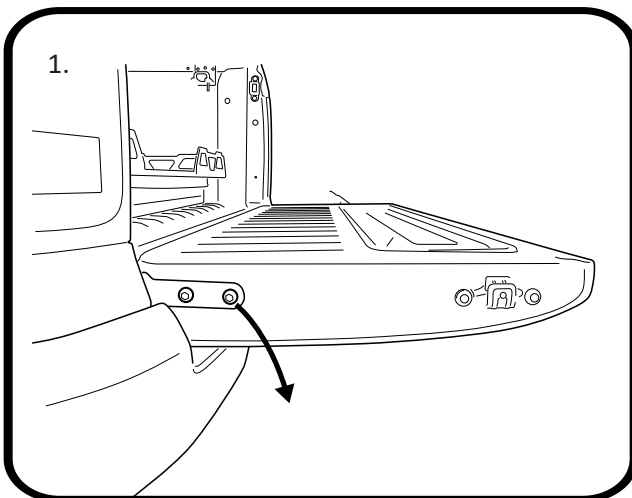

—STEP 7—



Drivers side

Remove indicated bolts, and retain.

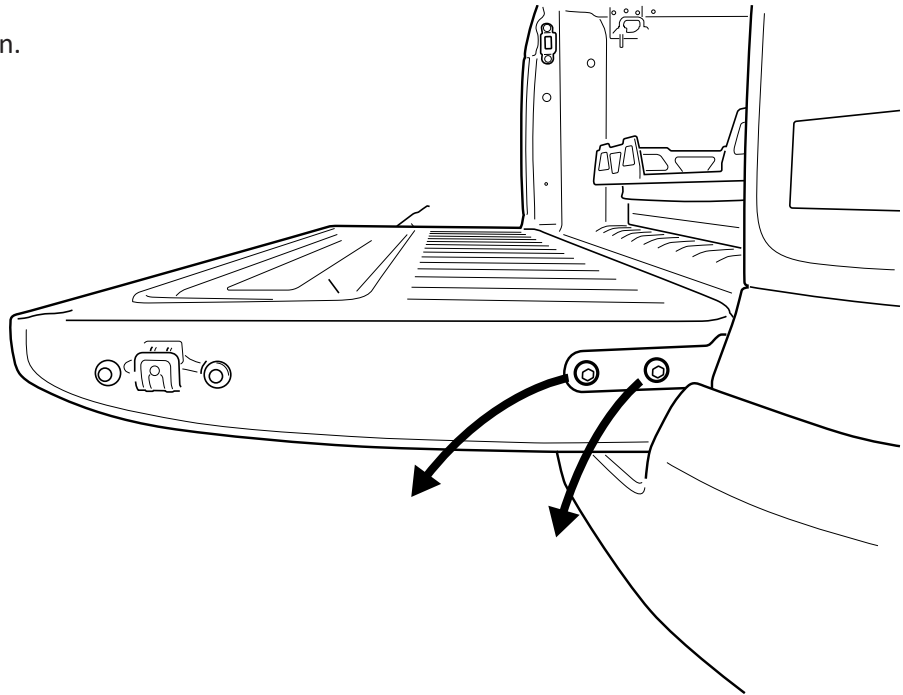

NOTE: Care must be taken not to loose alignment of the tailgate.

Place bracket TA-10LH over the tailgate hinge and fasten with retained factory bolt to location 1 & 2.

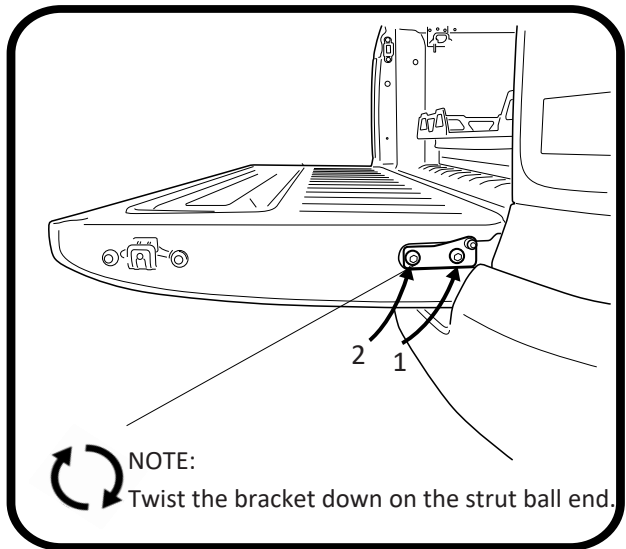
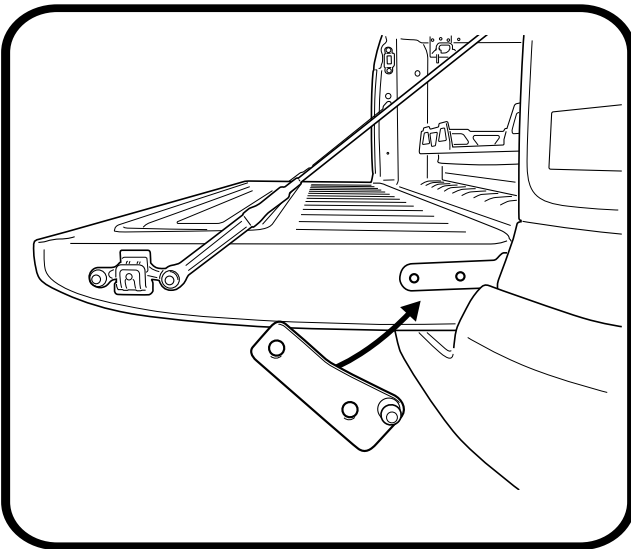

—STEP 8—

Now fit the shaft end of the strut to the stud ball on the tailgate.

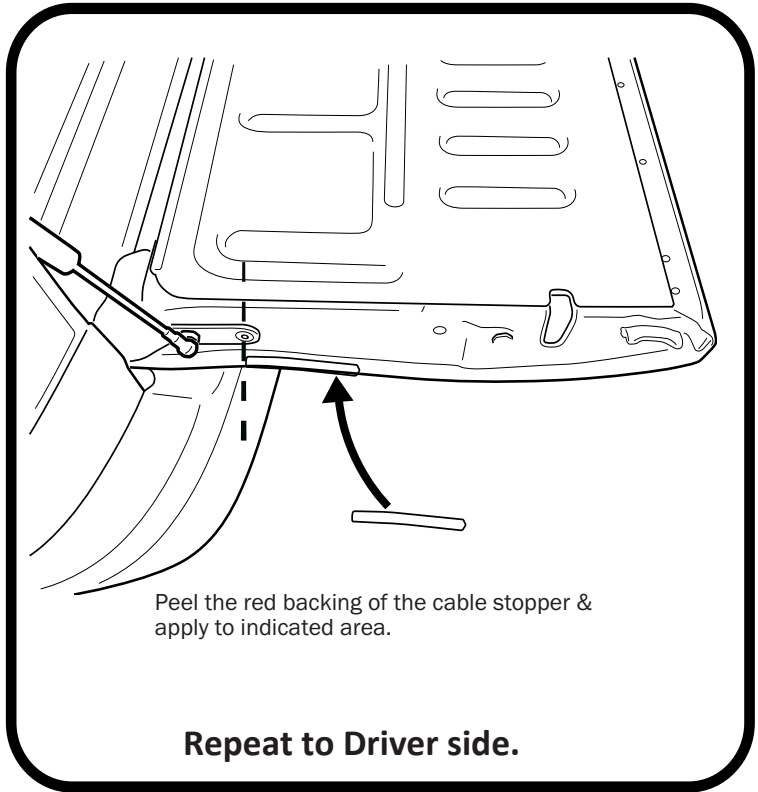
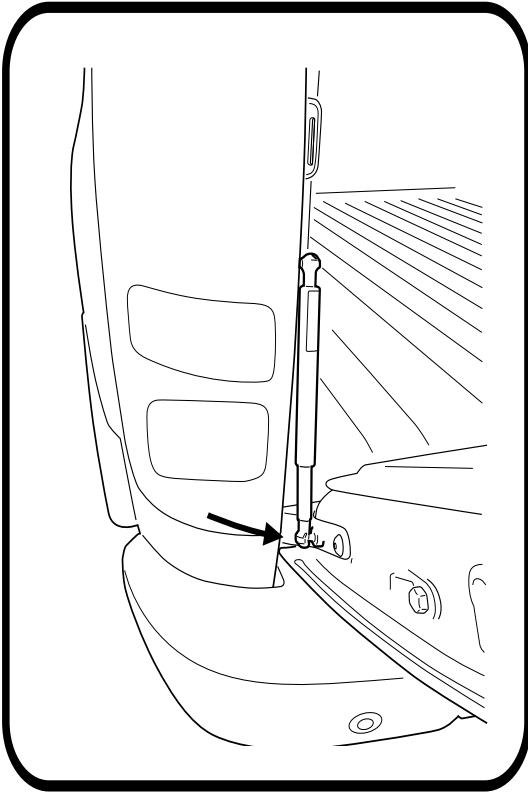

Peel the red backing of the cable stopper & apply to indicated area.

Repeat to Driver side.

—STEP 9—

NOTE: The driver side Strut (part number TRS) has a spacer which will need removing once installed.

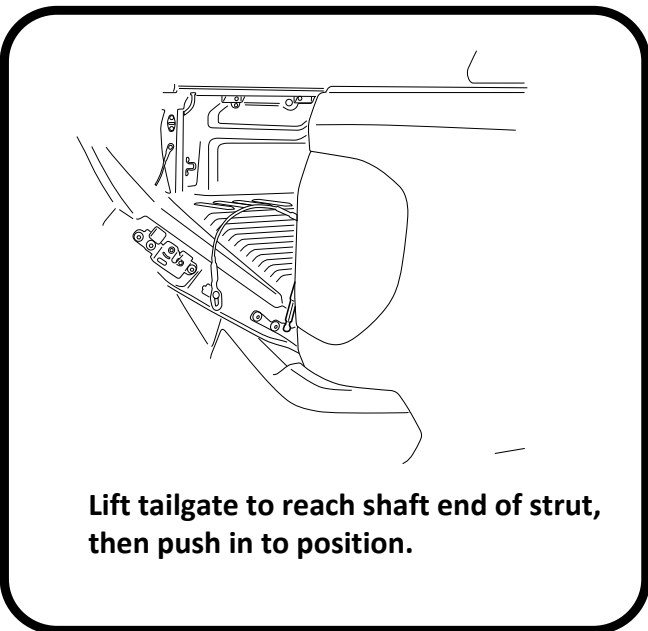

**Lift tailgate to reach shaft end of strut,
then push in to position.**

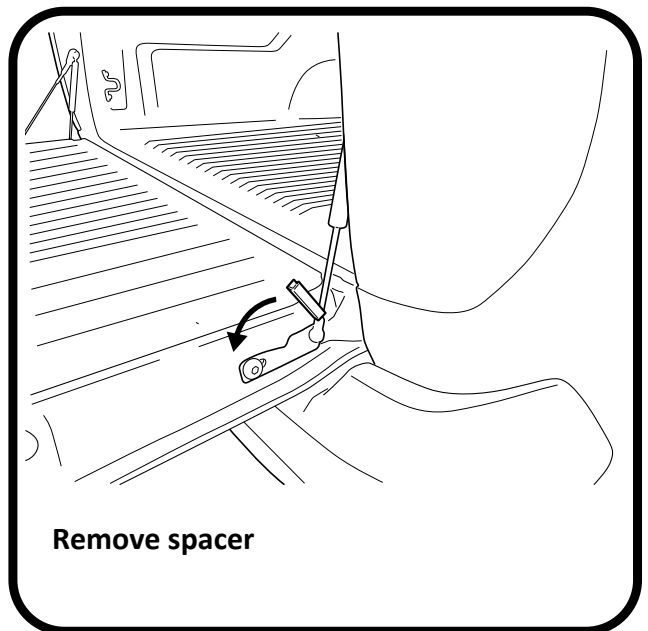

Remove spacer