



WWW.HSPUTELIDS.COM

1300 441 498

Part No: P18/B18

Fitting Time: 45mins



FORD RANGER | MAZDA BT50

HSP TAIL LOCK

FITTING INSTRUCTIONS

—GENERAL NOTES

- Read through the fitting instructions prior to installation of accessory.
- Ensure all recyclable components and packaging are discarded and recycled following local recycling regulations.
- Safely store and protect any removed vehicle components.

—SAFETY NOTES

- Check that all work practices comply with safety standards.
- Please wear appropriate clothing and use safety equipment.

—FITTING TIME



45mins

—PARTS SUPPLIED

Part Description	Part Number	Quality/ Length	CHECK LIST
TAIL LOCK ASSEMBLY			
Main Bracket	P18-A	1	
Lever	P18-B	1	
Actuator	ACT-01	1	
Wiring	CL-Short-Loom	1	
Patch	P-Patch	1	
FASTENERS			
Actuator Screws	36	2	
Lever Bolt	34	1	
Lever Nyloc Nut	35	1	
OTHER			
Cable Ties		5	
Fitting Instruction		1	

IMPORTANT

IF YOUR UTE HAS NO LOCK BARREL ON THE HANDLE, YOU WILL NEED TO PURCHASE THE FOLLOWING PART FROM FORD OR MAZDA DELAERSHIP.

OEM PART NUMBER : UC9M 657F8 A

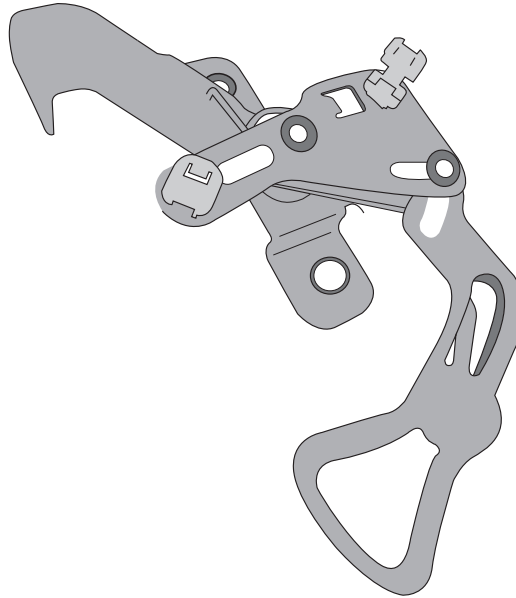

— STEP 1 —

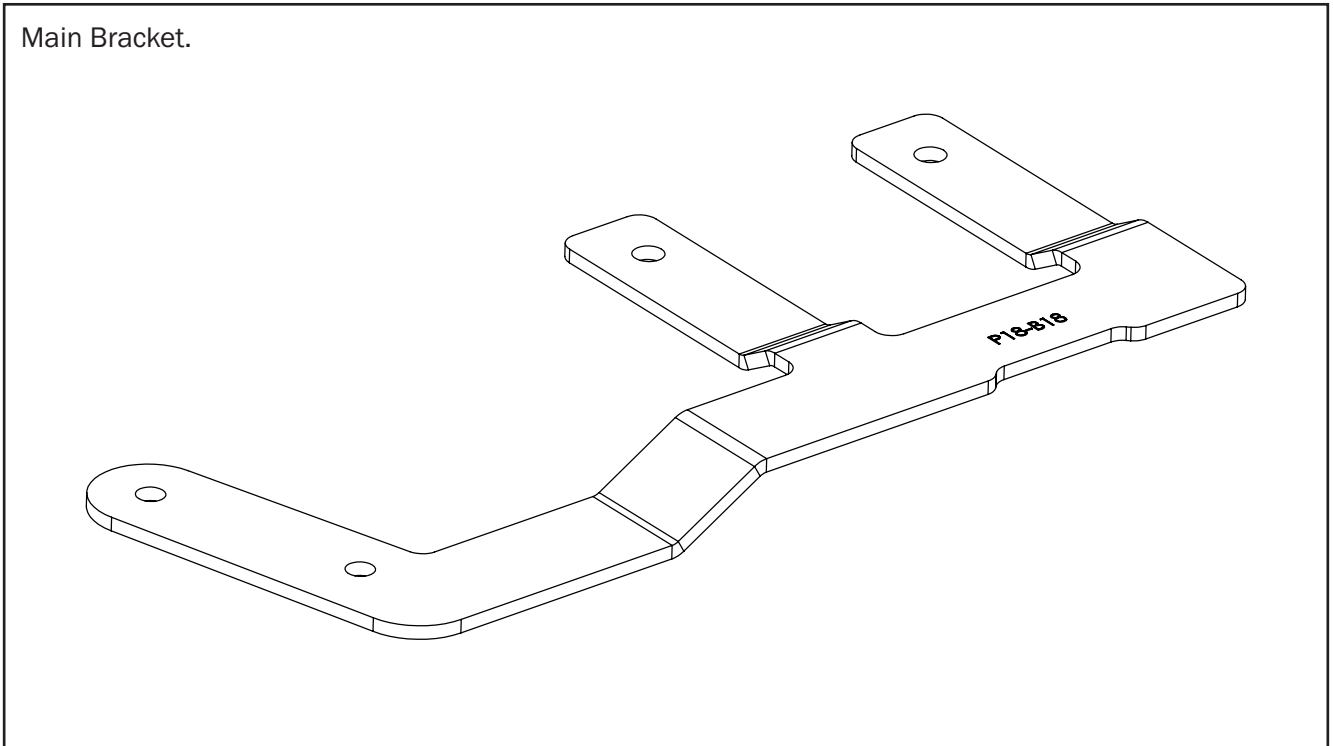

— STEP 2 —

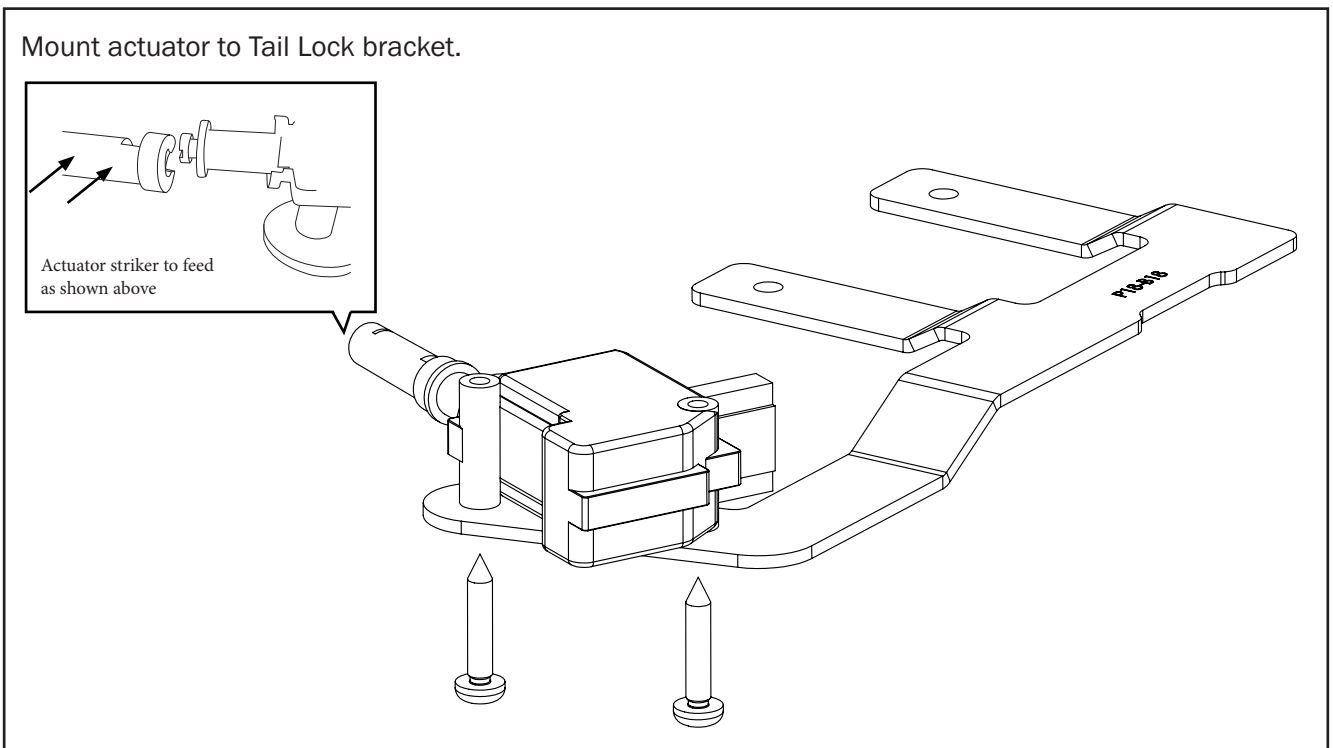

— STEP 3 —

Remove tail gate cover.

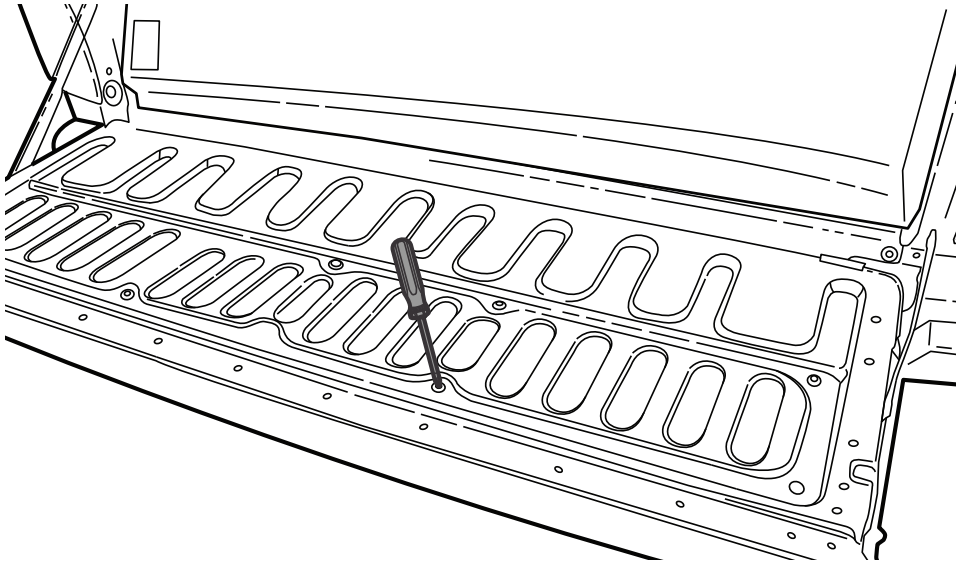

— STEP 4 —

Remove rods as shown.

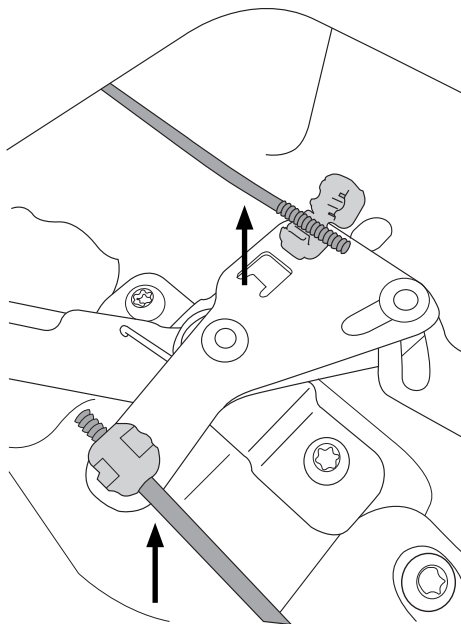

— STEP 5 —

Remove lock assembly.

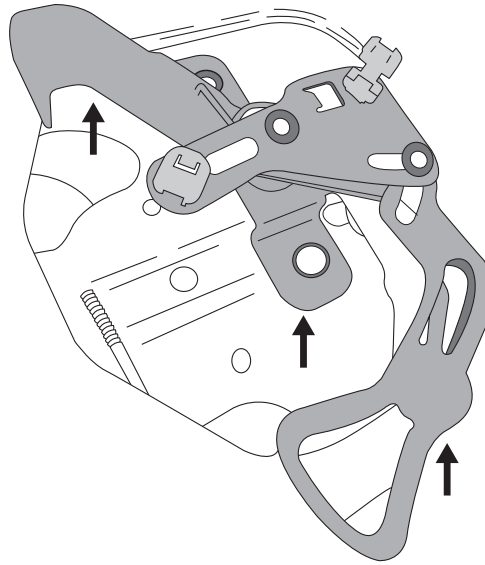

— STEP 6 —

Mount lever into lock assembly as shown.

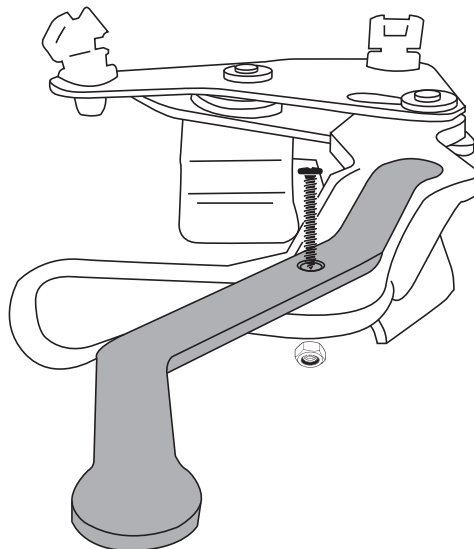

— STEP 7 —

(i) Fit Tail Lock assembly and (ii) ensure lever pin is inserted into the actuator striker.

i

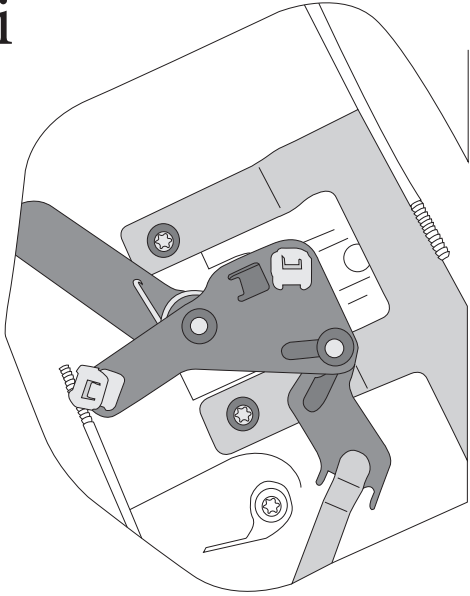

ii

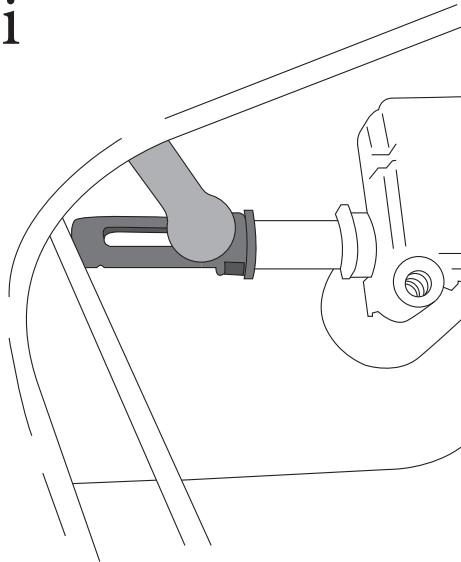

— STEP 8 —

Connect rods as shown.

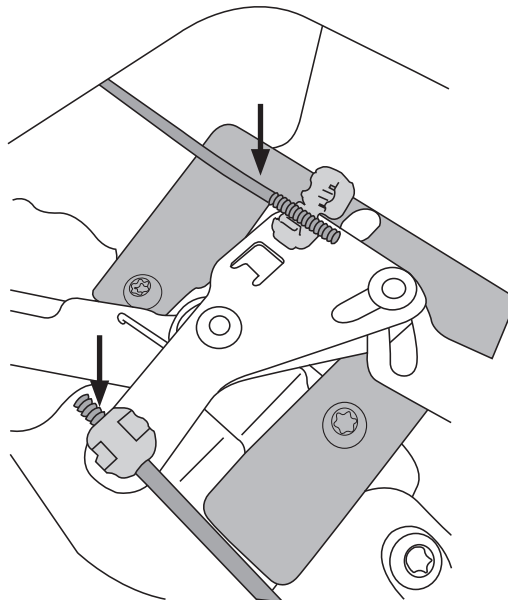

— STEP 9 —

Connect the wiring to the actuator then route the actuator wiring harness (1) out of the tailgate and underneath the vehicle following the existing vehicle harness.

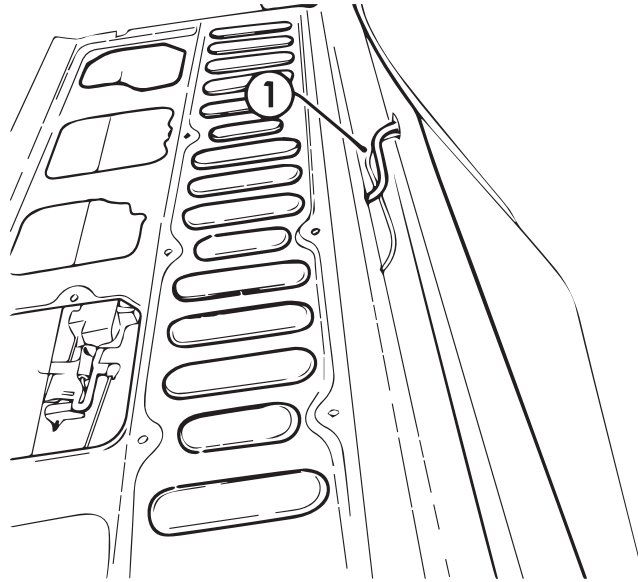

— STEP 10 —

Run wiring from tailgate to fuel cap.

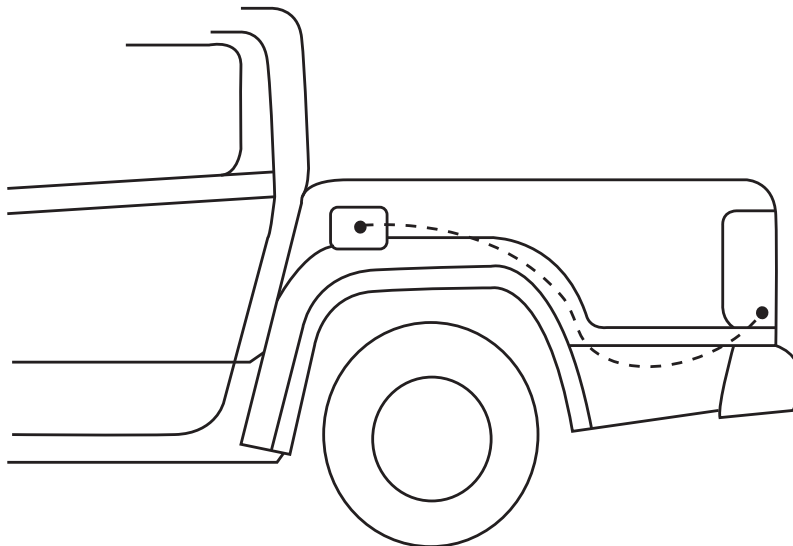

— STEP II —

Remove the retain the 6x wheel arch liner scrivets at the front and top of the LH rear wheel well. If the vehicle is fitted with fender flares, remove and retain the forward 3xFF scrivets and 1xFF clip at the top from the LH rear wheel FF. Pull Back the wheel arch liner to get access to the fuel flap harness connectors.

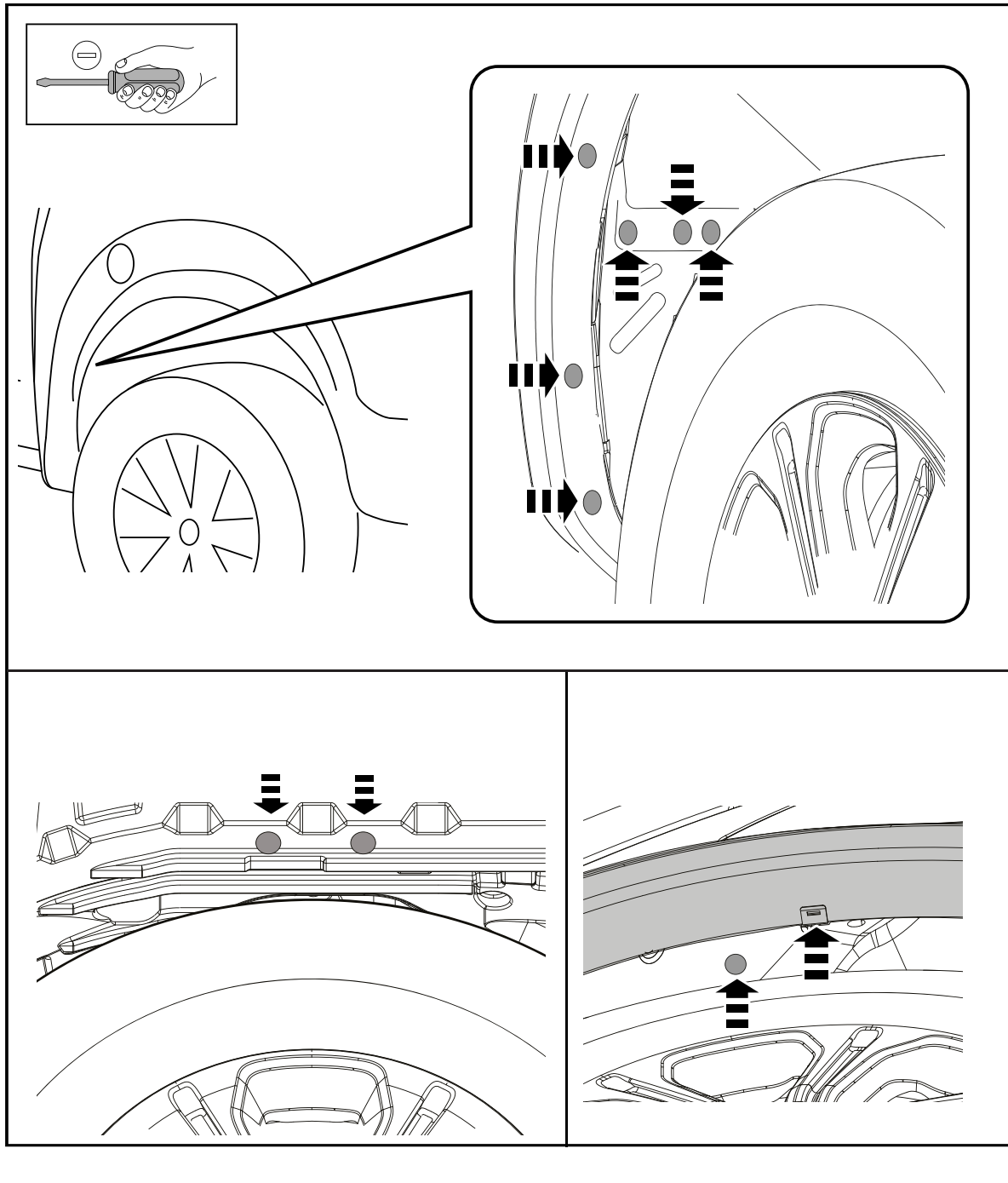

— STEP 12 —

Disconnect the fuel flap connector (1). Patch the shorter (two grey connectors) between the two fuel flap connectors.

Use one zip tie to secure the harness to the existing harness.

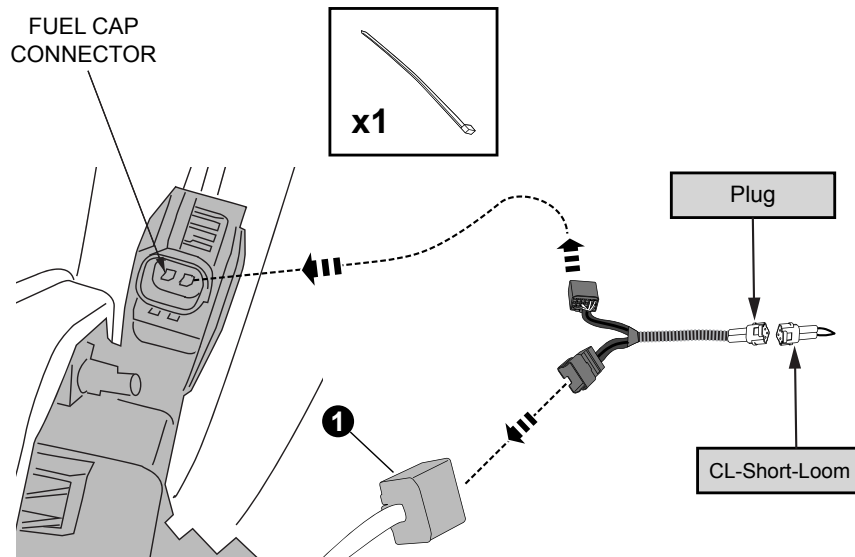

— STEP 13 —

Re-fasten the tailgate cover.

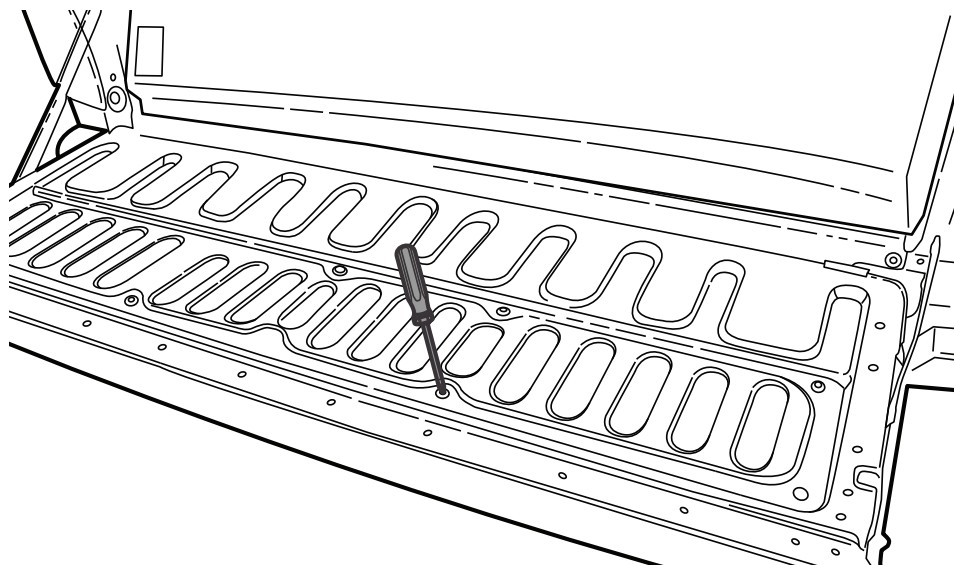

— FITTING COMPLETED —