



INSTALLATION INSTRUCTIONS

**To suit Volkswagen Amarok Dual Cab with
SAILPLANE**



INSTALLATION TIME: 2.5 Hours (Approximately)

IMPORTANT	<ul style="list-style-type: none"> • Do not stand/sit or rest heavy objects on Roll R Cover • Humans or animals are not to be under the closed cover at any given time • Tonneau Cover is not dust or water tight • If contact with volatile chemicals occur, clean Cover with mild detergent and water solution 			
Care Instructions	<ul style="list-style-type: none"> • Read Instructions fully before commencing installation. • Clean Cover with a mild detergent and water solution • Do not use abrasive cleaners or solvents • Refer to manufactures instructions applicable to power drill. • Protect Tub floor against scratches during installation process. 			
Maintenance	Refer to Maintenance instructions.			
Tools Required	<table style="width: 100%; border: none;"> <tr> <td style="vertical-align: top;"> <ul style="list-style-type: none"> • Pen / Marker • Centre Punch • Drill & Drill bits • Caulking Gun • Silicon - Non Acetic </td> <td style="vertical-align: top;"> <ul style="list-style-type: none"> • Scissors & Knife • Spanner & Socket • Tape measure • Holesaw • Filing tool </td> <td style="vertical-align: top;"> <ul style="list-style-type: none"> • Soapy water solution • Allen Key set • Screw driver • Rust Inhibitor • Trim Removal Tool </td> </tr> </table>	<ul style="list-style-type: none"> • Pen / Marker • Centre Punch • Drill & Drill bits • Caulking Gun • Silicon - Non Acetic 	<ul style="list-style-type: none"> • Scissors & Knife • Spanner & Socket • Tape measure • Holesaw • Filing tool 	<ul style="list-style-type: none"> • Soapy water solution • Allen Key set • Screw driver • Rust Inhibitor • Trim Removal Tool
<ul style="list-style-type: none"> • Pen / Marker • Centre Punch • Drill & Drill bits • Caulking Gun • Silicon - Non Acetic 	<ul style="list-style-type: none"> • Scissors & Knife • Spanner & Socket • Tape measure • Holesaw • Filing tool 	<ul style="list-style-type: none"> • Soapy water solution • Allen Key set • Screw driver • Rust Inhibitor • Trim Removal Tool 		

PERSONAL PROTECTIVE EQUIPMENT:



Rubber Gloves



Goggles



Hearing Protection

BOX CONTENTS

LEFT & RIGHT SIDE RAIL

S2.5-DC-AE-002ps-A6 

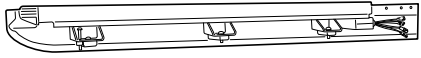
S2.5-DC-AE-003ds-A6 



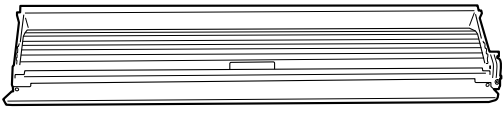











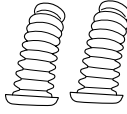

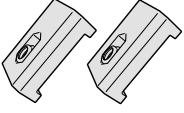
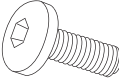
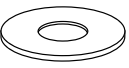

CANISTER ASSEMBLY

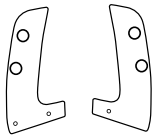

S3-DC-AF-A4R-001/002

CANISTER TOP COVER  S2.5-DC-AE-005 -A6

SPECIFIC KIT A6R

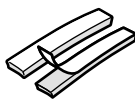
<p>COVER END CAPS</p>  <p>S2.5-DC-PI-004ps</p>  <p>S2.5-DC-PI-004ds</p>	 <p>COUNTERSUNK SCREW Qty - 4</p>	 <p>CABLE TIE Qty x 16</p>	 <p>BATTERY LOOM S2.75</p>	 <p>Drainage pipe Qty - 2</p>	 <p>M8 NUT Qty - 6</p>
 <p>SIDERRAIL CLAMP Qty - 6</p>	 <p>M8 x 35mm Qty - 6</p>	 <p>M8 WASHER Qty - 6</p>	 <p>M8 SPRING WASHER Qty - 6</p>	 <p>3M PRIMER</p>	 <p>M6 WASHER Qty - 12</p>
 <p>M6 x 20 ALLEN Head Bolt Qty - 12</p>	 <p>M6 SPRING WASHER Qty - 12</p>	 <p>SIDERRAIL HOLE GASKET Qty - 12</p>	 <p>Foam 25mm wide by 5mm thick Qty 2 x 1.7m</p>	 <p>Foam 10mm wide by 14mm thick Qty 2 x 1.7m</p>	 <p>GUSSET Qty - 2</p>
 <p>SPACER Qty - 12</p>	 <p>SCREW Qty - 4</p>	 <p>CL-LOOM-SHORT</p>	 <p>A-PATCH-K</p>	 <p>15mm Foam tape Qty-2</p>	

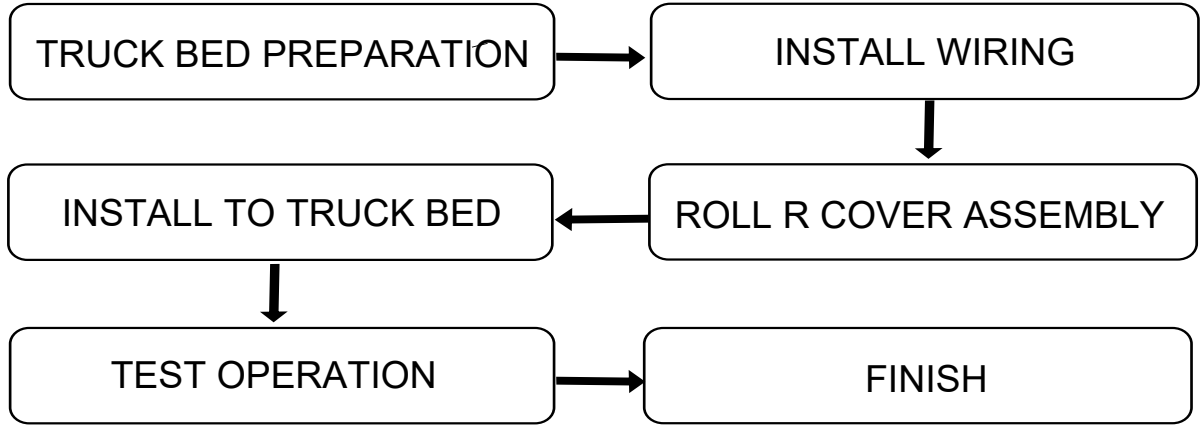

TUB PREPARATION

1. Remove sailplane from tub by unfastening the bolts underneath.
2. Remove all hardware on the tub that was holding the sailplane in place & discard.

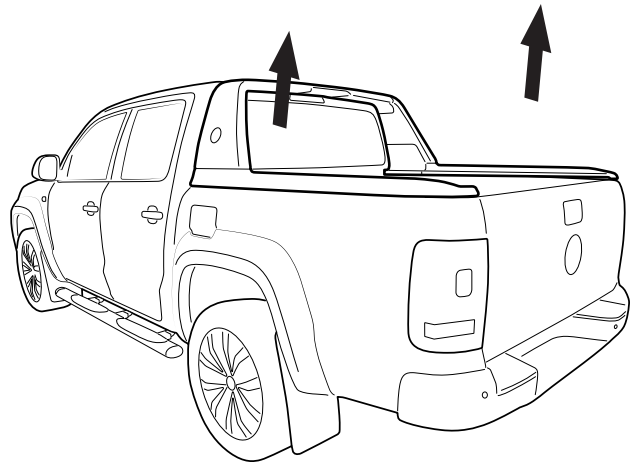

Clean areas as indicated.

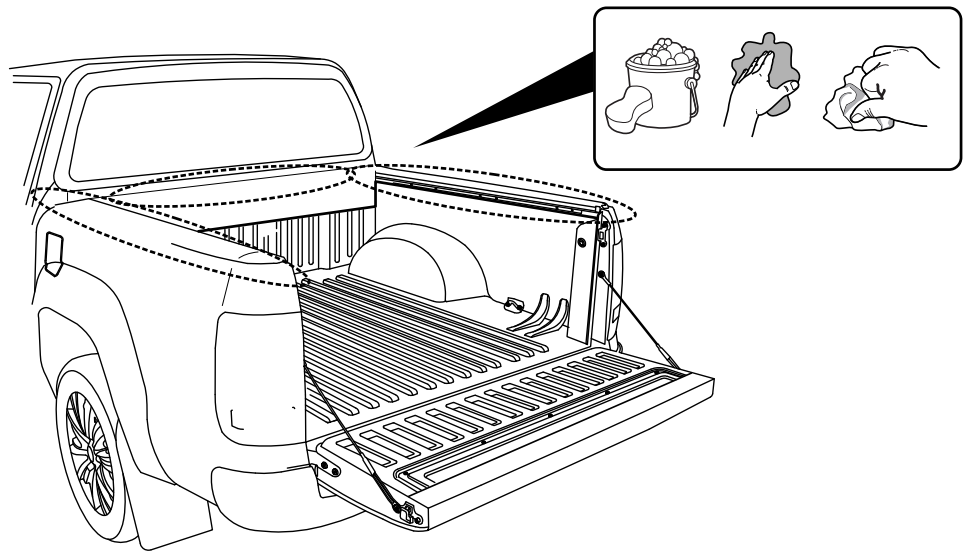

Measure 10mm down from top of tailgate and trim tailgate liner.

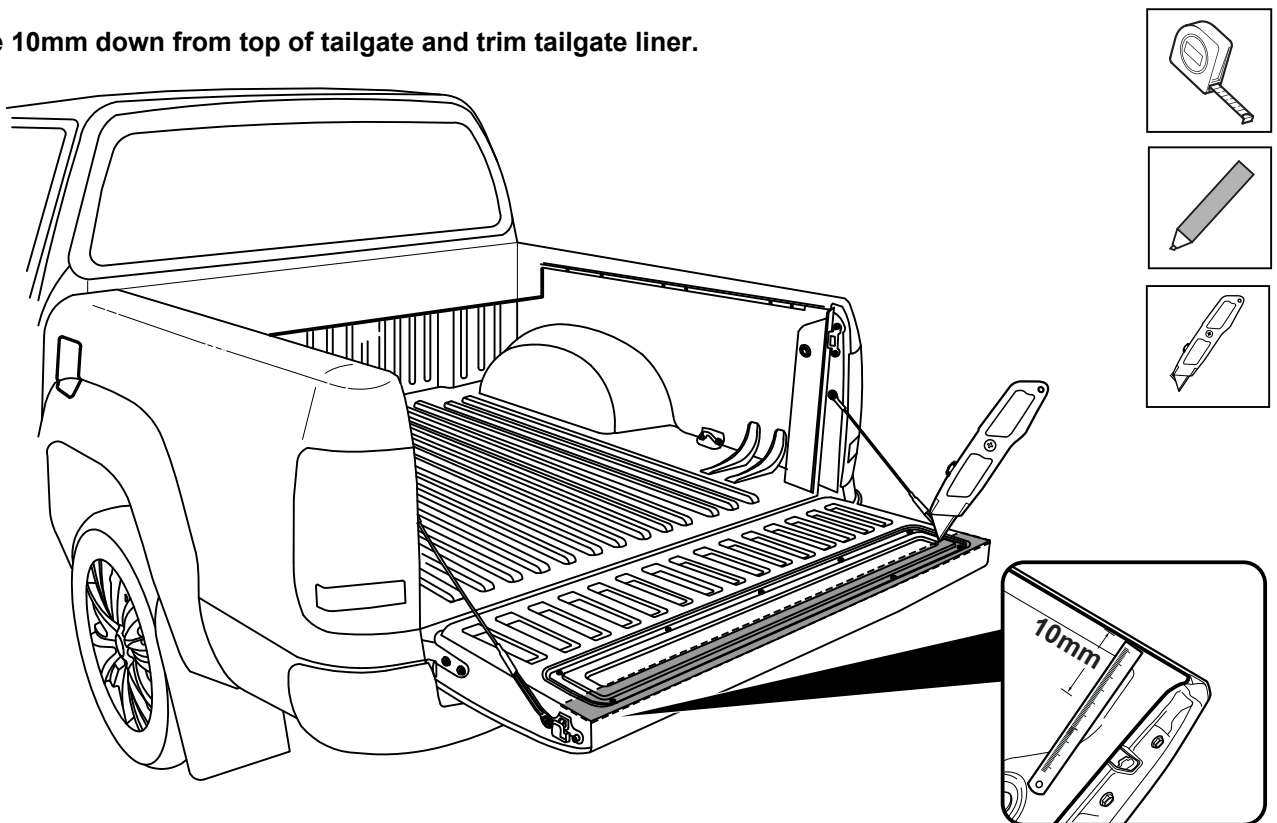

Measure down from top of assembly bar 210mm & 135 mm from inside wall of bed liner as shown. Repeat to the other side. Using a 50mm hole-saw drill the liner only as indicated.

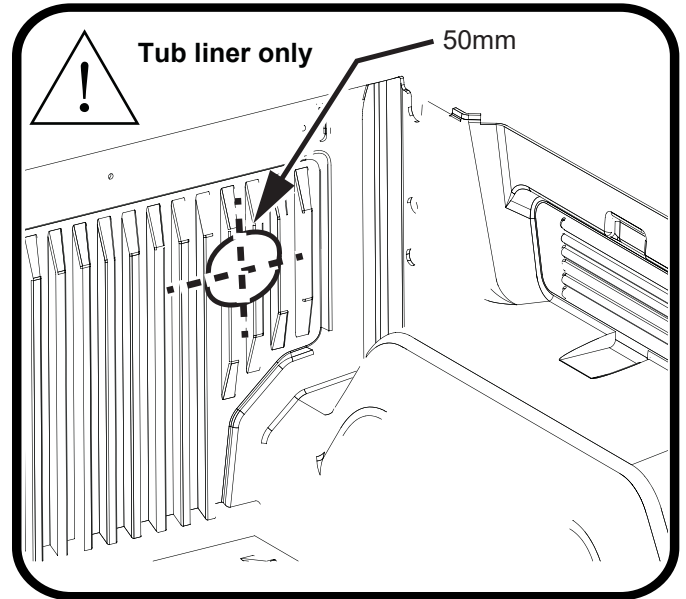
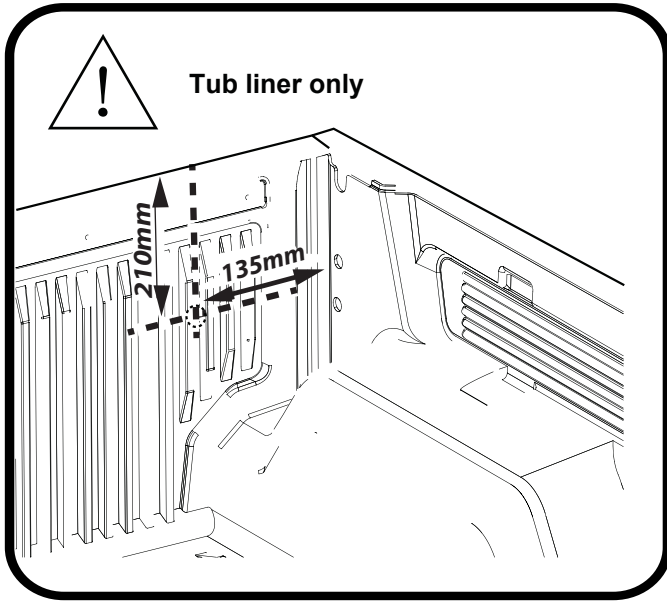
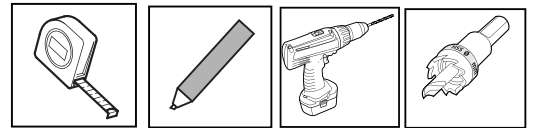

Measure down from top of headboard 210mm & 145mm from inside wall of bed as shown. (or 115mm if measuring from the side of the top rail) Repeat to the other side. Using a 30mm hole-saw drill through tub front panel, file away any sharp edges. Apply anti rust coating. Repeat to other side.

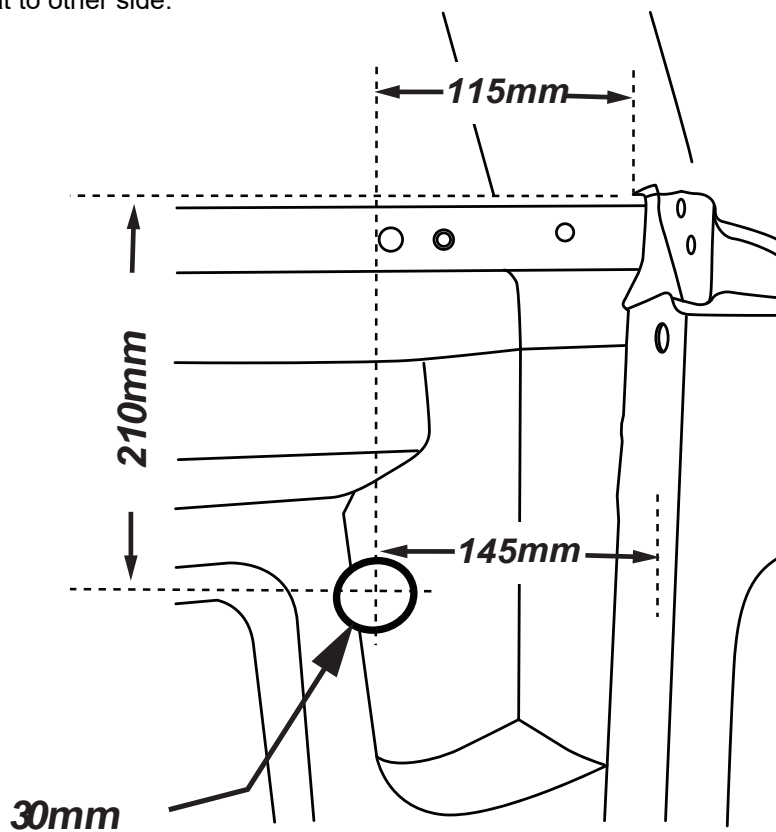
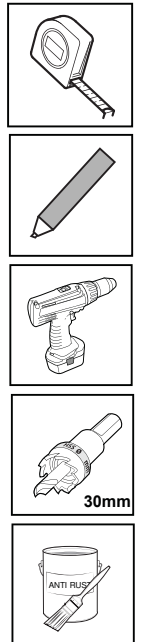

! ATTENTION: Do not exceed 30mm hole.

Seal any exposed gaps or holes on the front panel of the Ute bed with sealant.

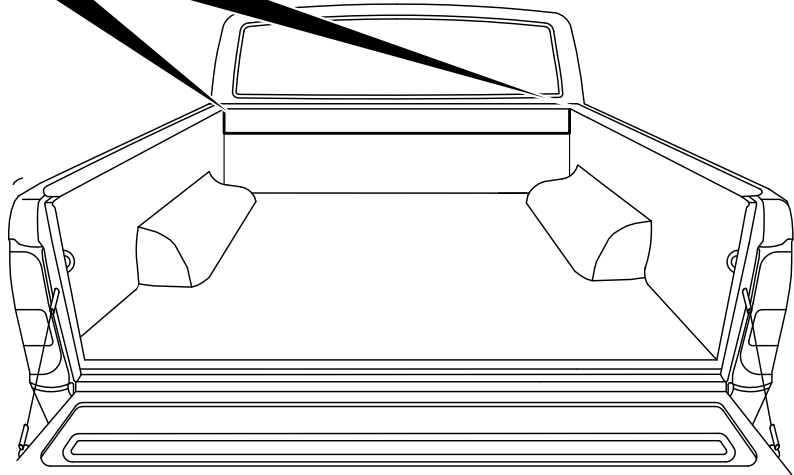
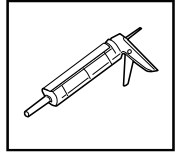
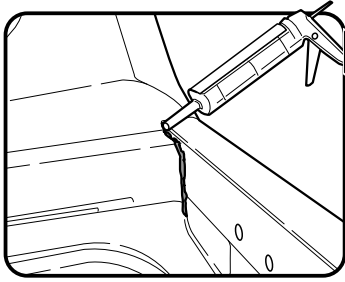

Carefully unpack the box.

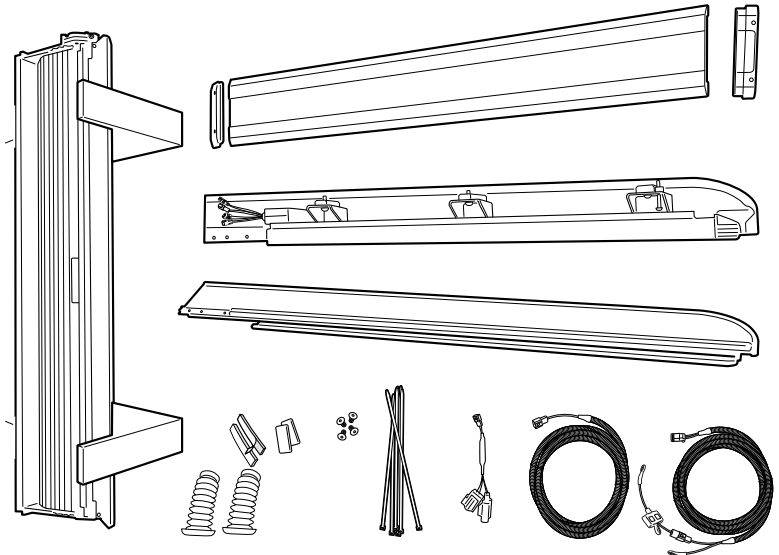
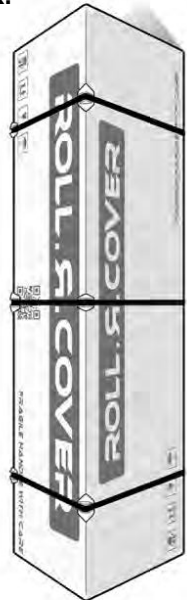

Install front drain pipes (55mm diameter end of hose) through pre-drilled holes on the front tub panel.



Note: With care push tube in.
Taking care pull the tube back so it seals correctly against the front panel of the tub.

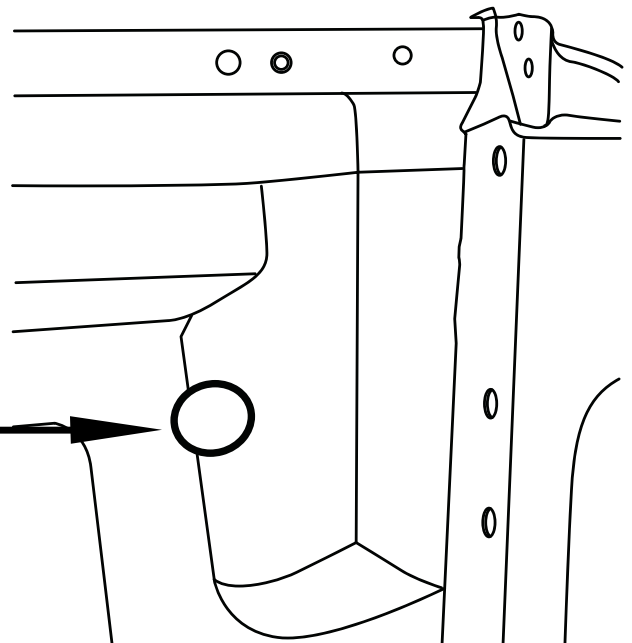
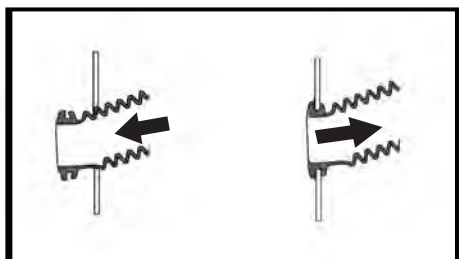

Disconnect fuse patch from battery loom S2.75.

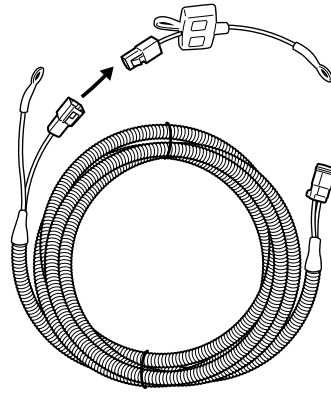

Wiring Harness steps

1 Feed Battery Loom S2.75 through the cavity

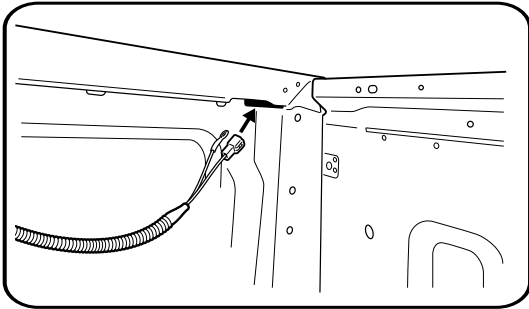

3

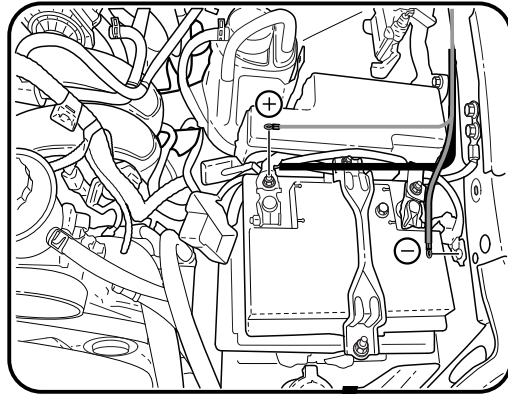

2

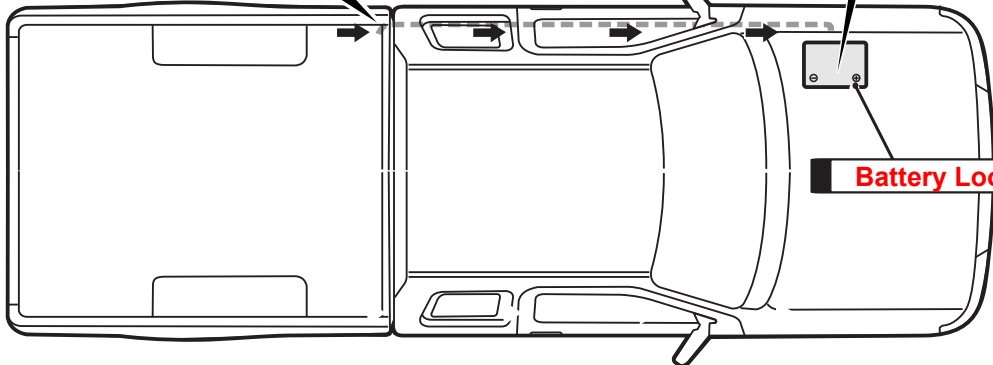

Run the wiring from the front corner cavity (leaving 300mm in the tub) to the battery over the chassis rail. Making sure to keep away from hot obstructions and cable tie every 400mm. Reconnect fuse patch to battery loom S2.75, now attach fuse patch to positive of battery and earth to the body of the Ute.

Feed CL-Short-Loom through the cavity.

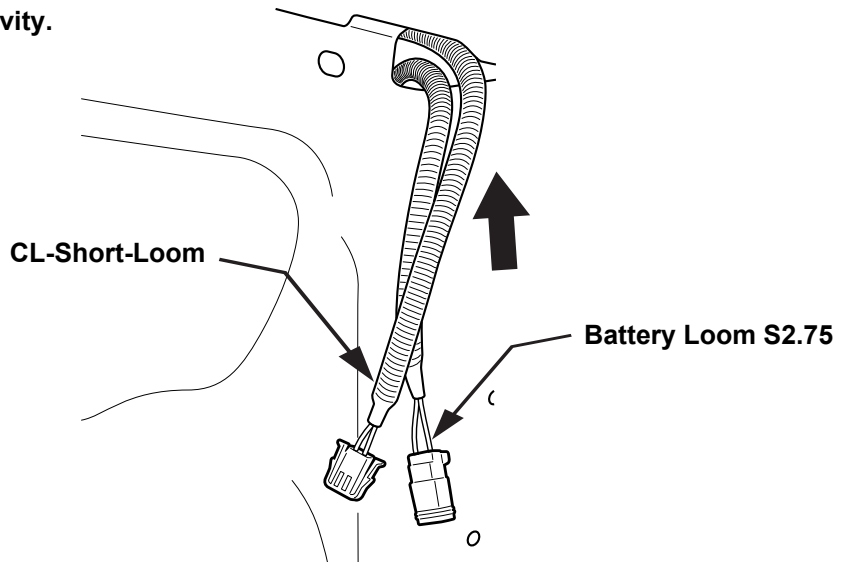

Locate connectors behind rear LHS wheel.

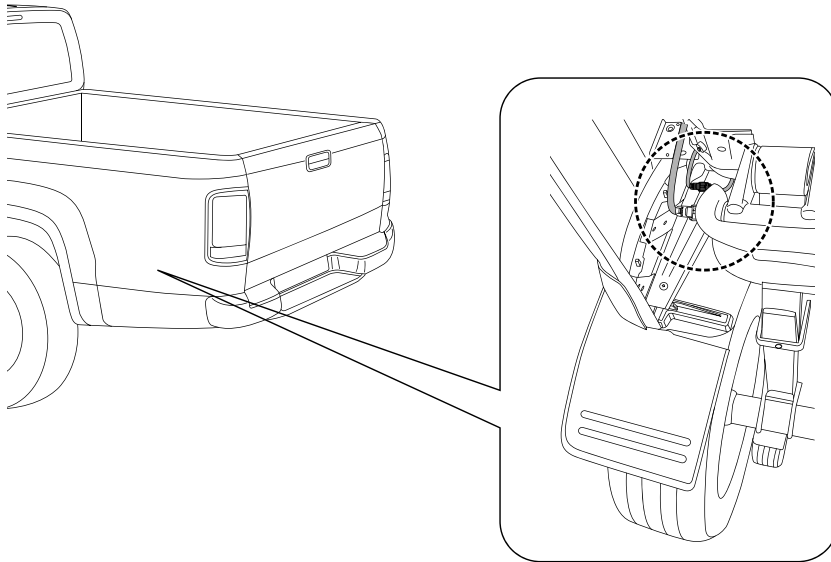

Disconnect the existing vehicle harness connectors under the vehicle

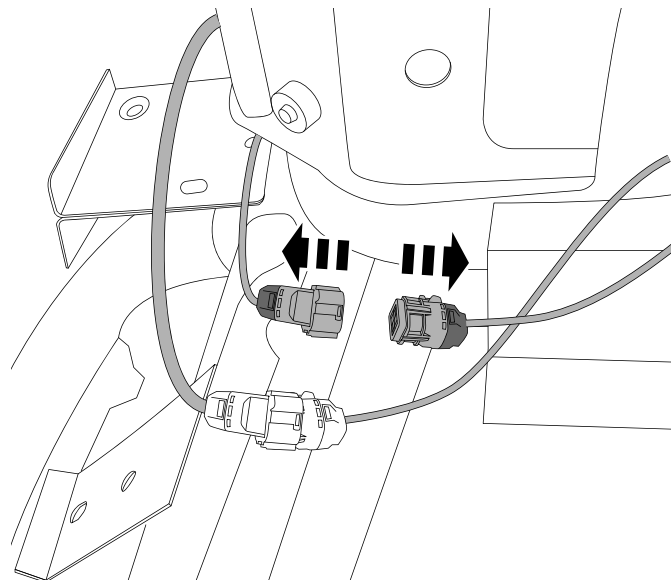

Connect the vehicle harness to A-patch supplied. Then connect the A-patch to the CL short loom.

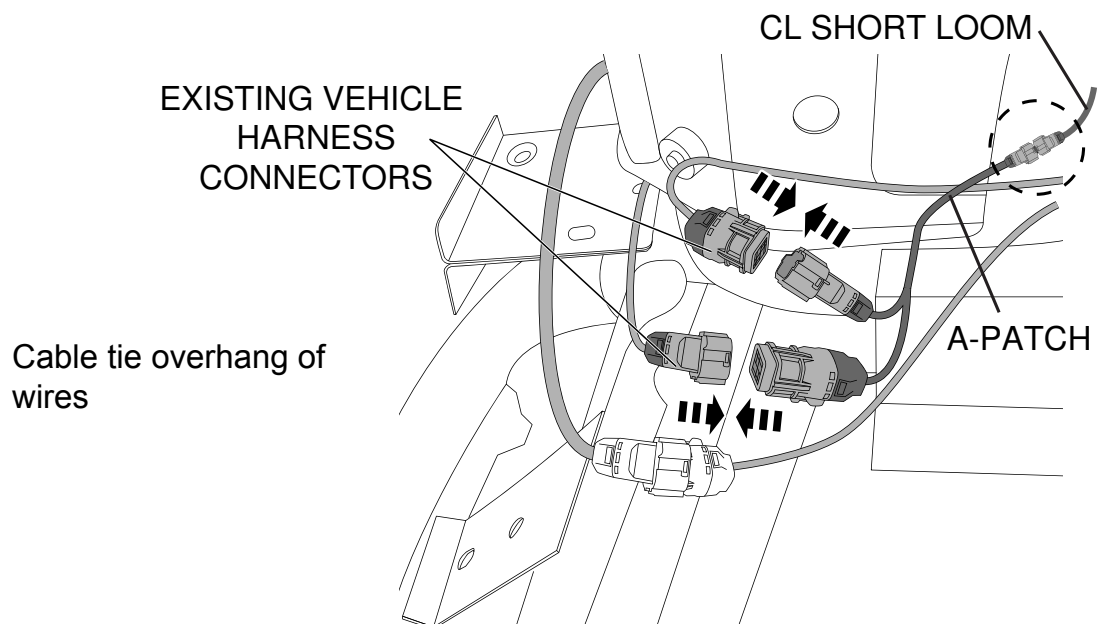

keep the cannister in the foam blocks from the packaging for assembly.

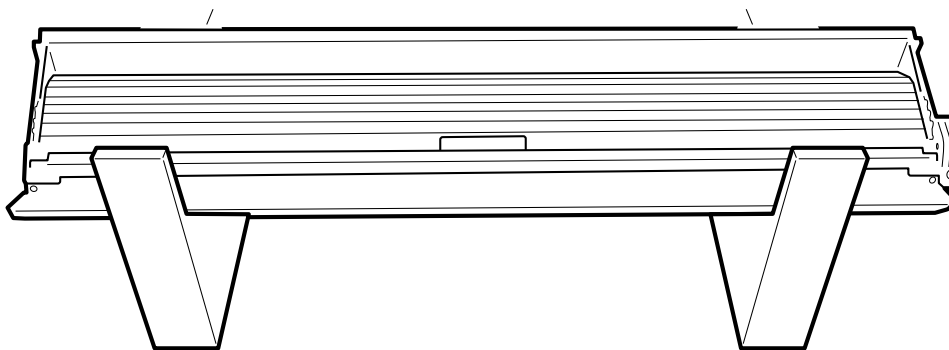

With assistance turn the canister on its back on the foam blocks.

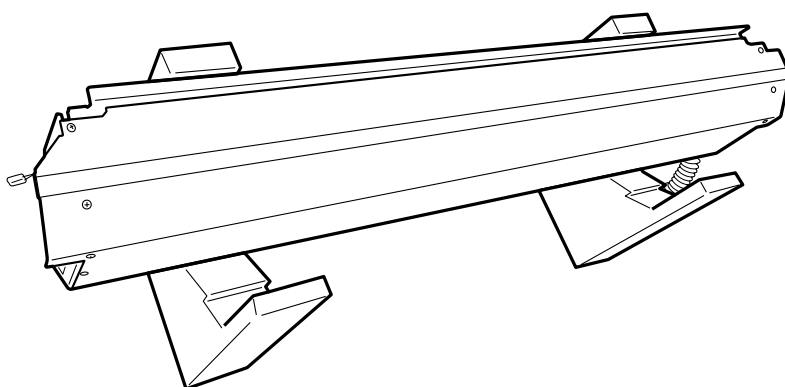

Disengage motor from the axle by unfastening the 3 Screw as indicated. Retain all parts.

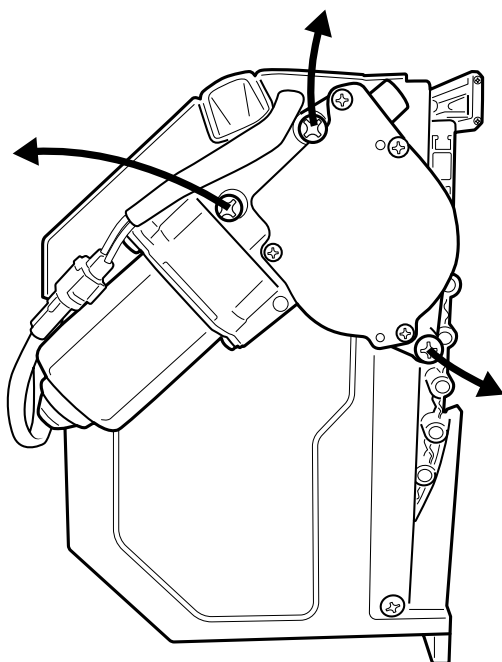

Remove and retain the 3 screw from the canister as indicated.

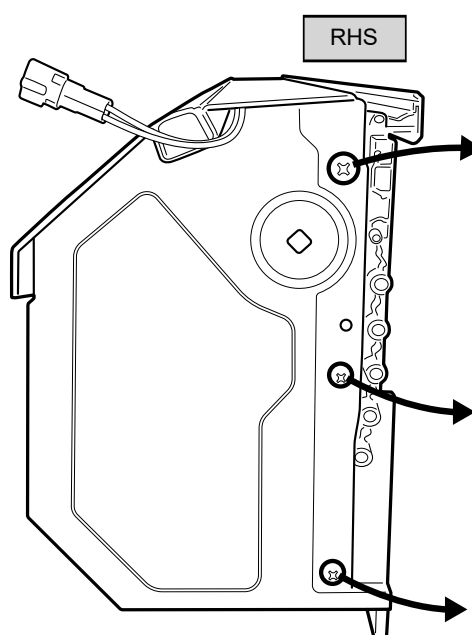
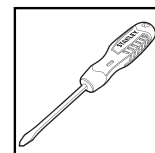

Now on the other side, remove and retain the 4 screws from the canister as indicated.

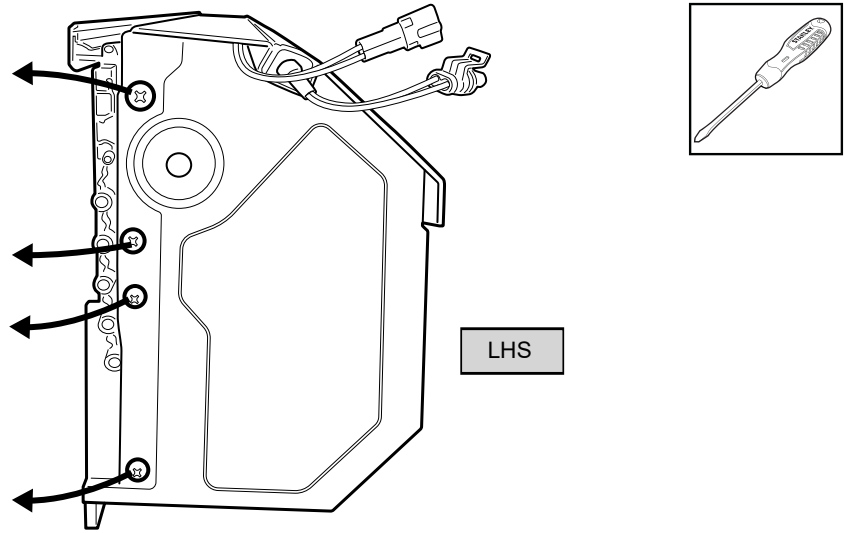

Align side rail to side of canister, guide the track to go in between the curtain end robber stop.

NOTE: LHS side rail to be assembled first.

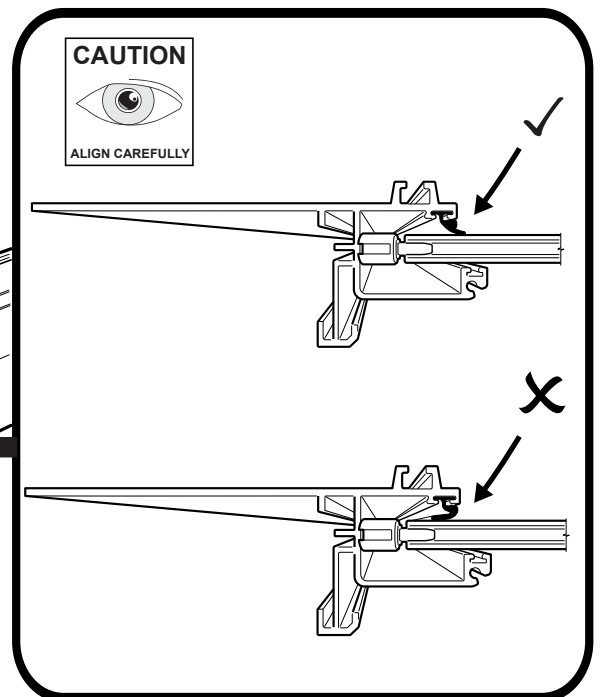
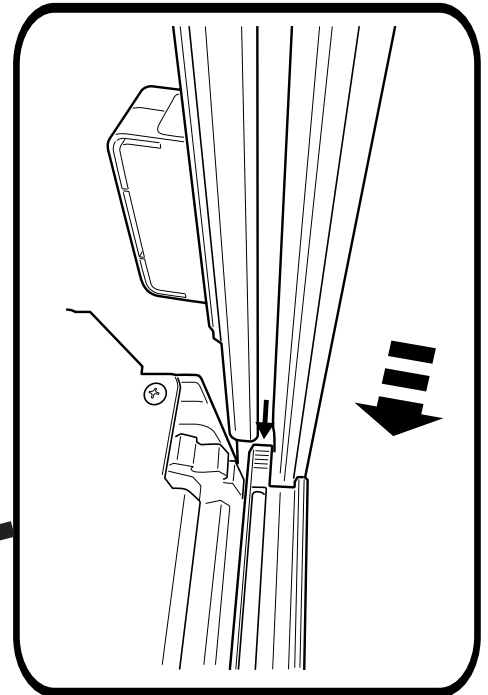
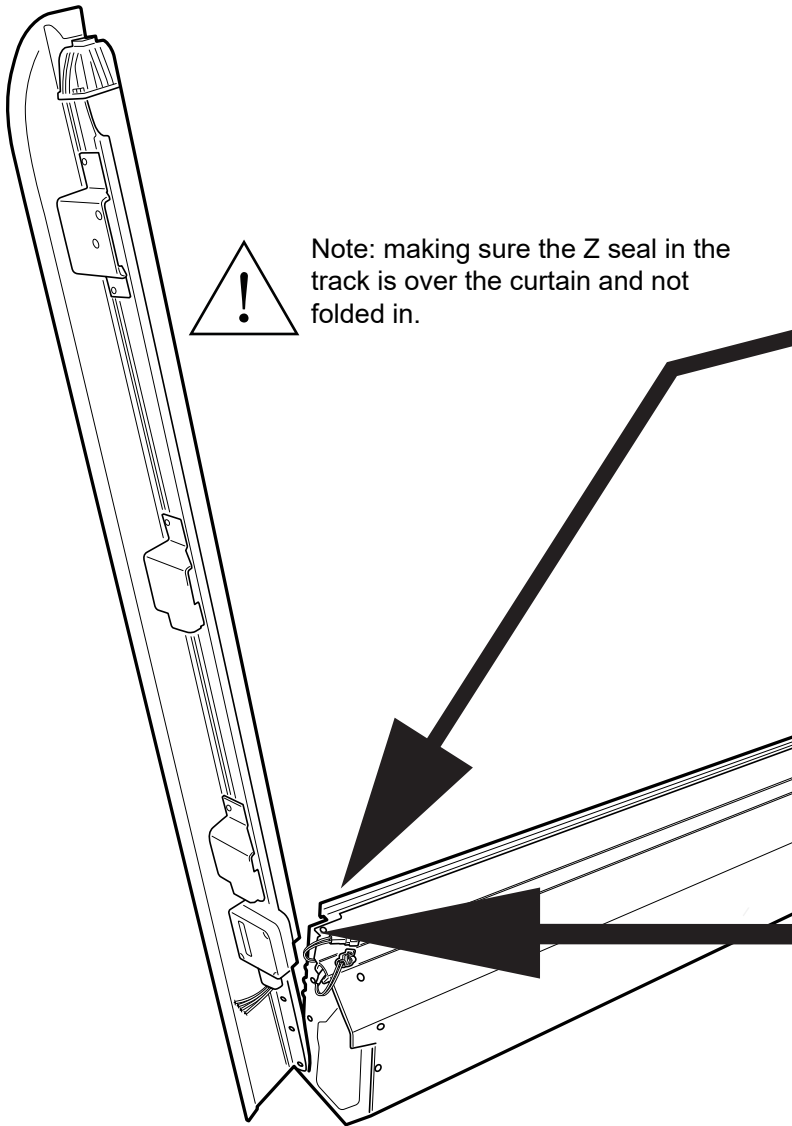

Fasten the side rail using the retained screws, spring washer and washer.

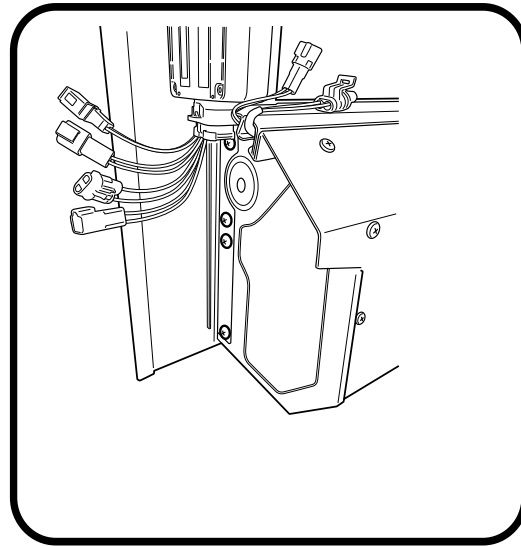
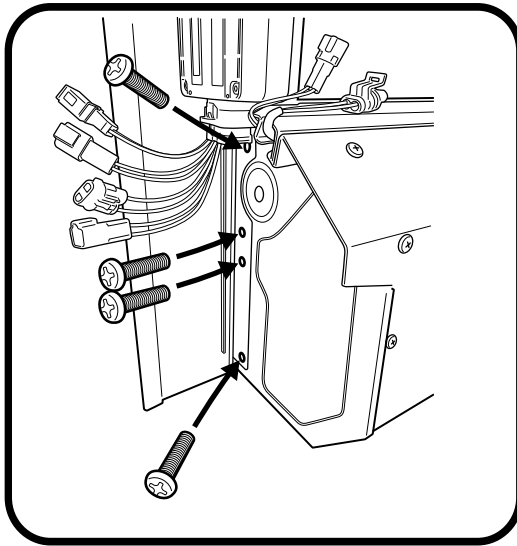
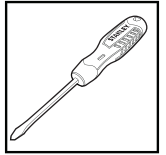

Connect motor connector to receiver

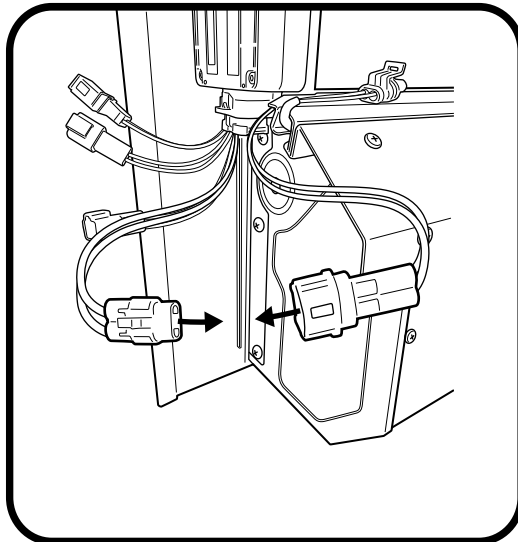

Connect LED Loom to receiver

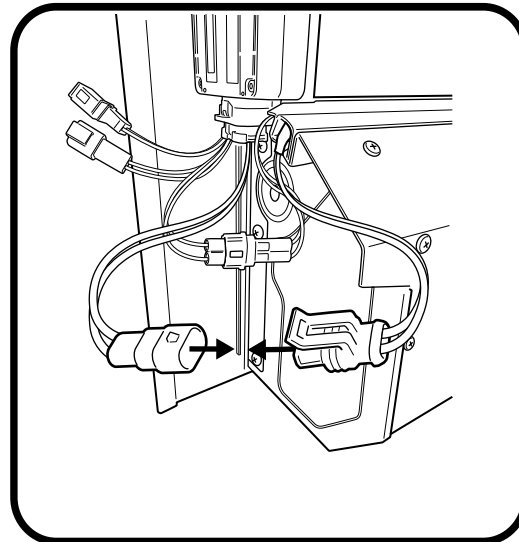

Align side rail to side of canister, guide the track to go in between the curtain end robber stop.

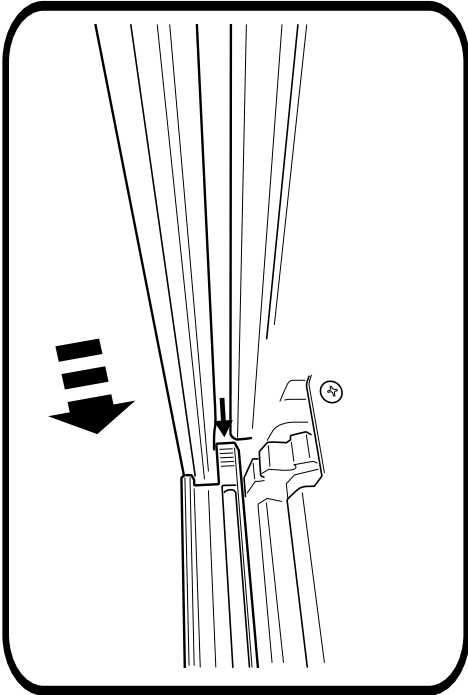

Note: making sure the Z seal in the track is over the curtain and not folded in.

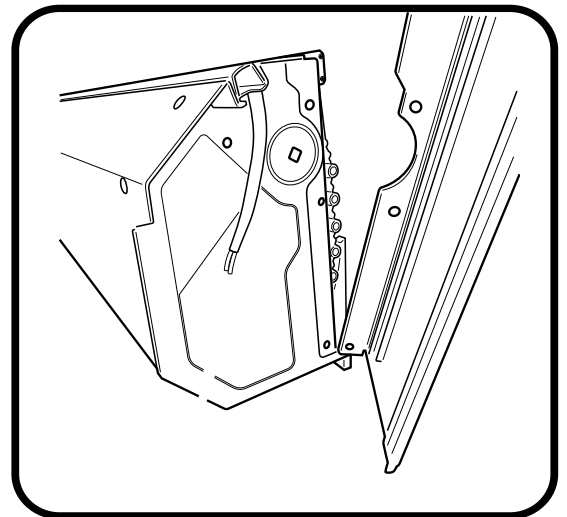
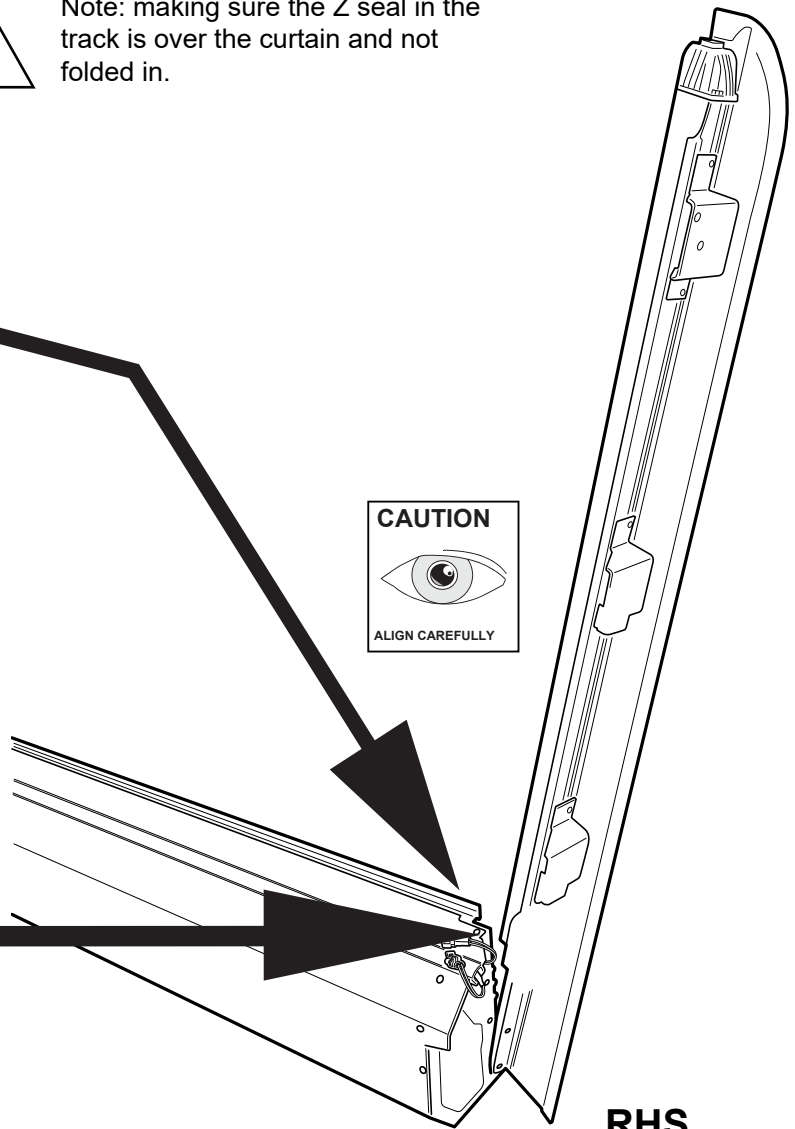
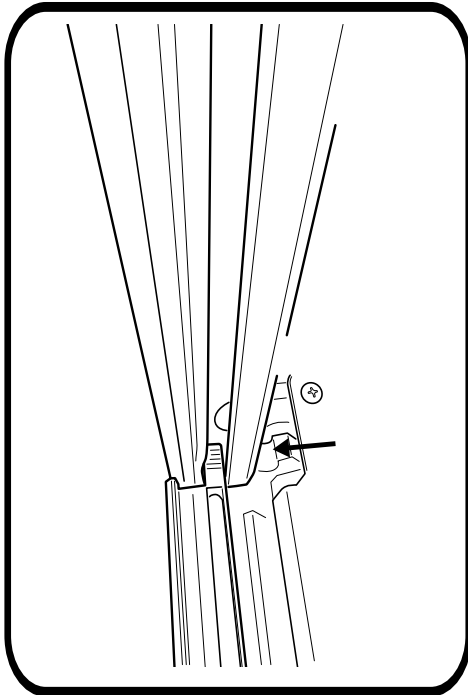

Fasten the side rail using the retained screws, spring washer and washer, only to the locations indicated.

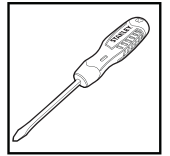
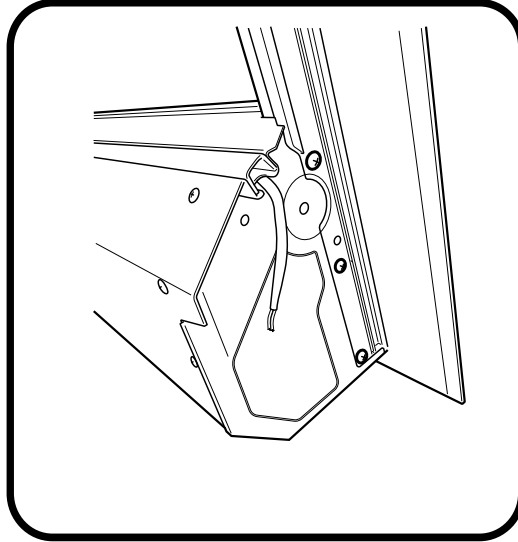
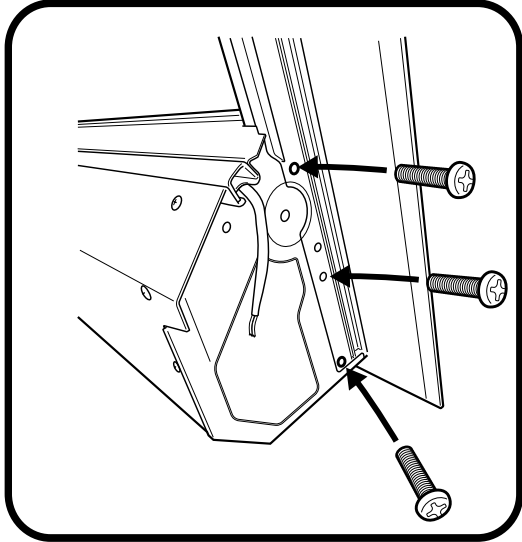

Feed M6 bolt through spring washer, motor and rubber bush.

NOTE: Rubber bush orientation has to be as per image. (side with text on rubber, to face the motor).

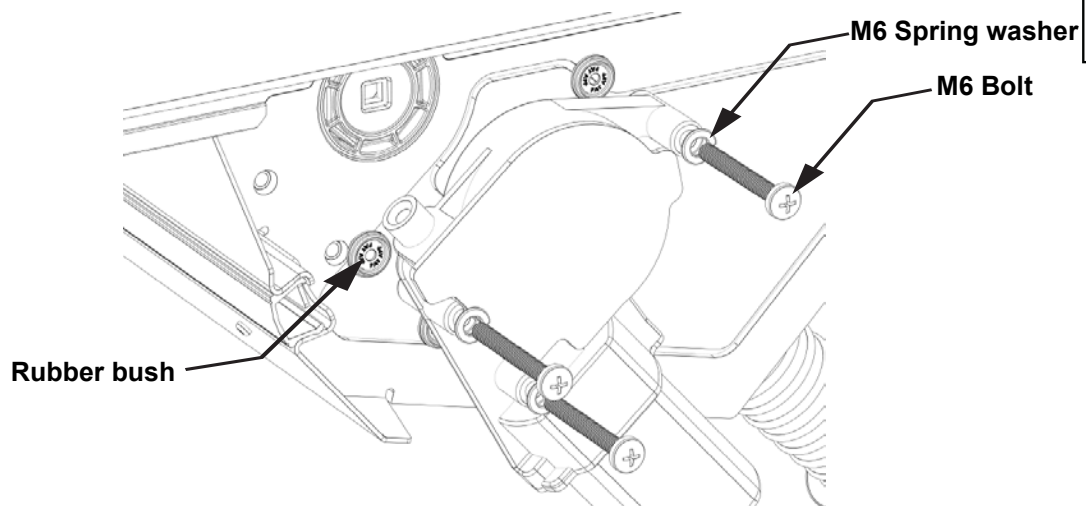

Align & insert motor shaft to axle.

NOTE: Pull / push curtain for axle to rotate.

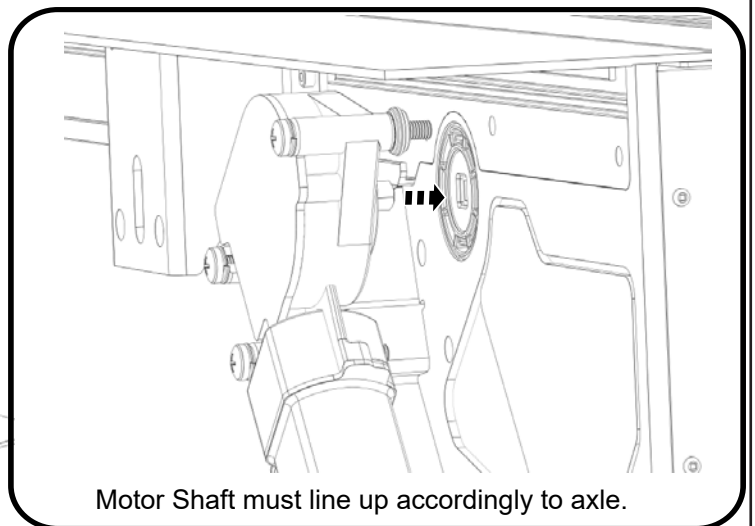
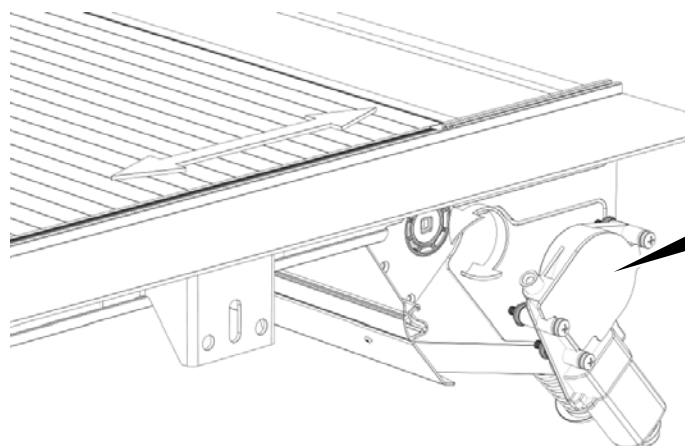

Fasten all 3 screws to 2nm torque. Over tensioning will cause operating issue's.

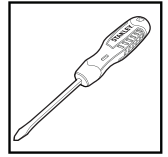
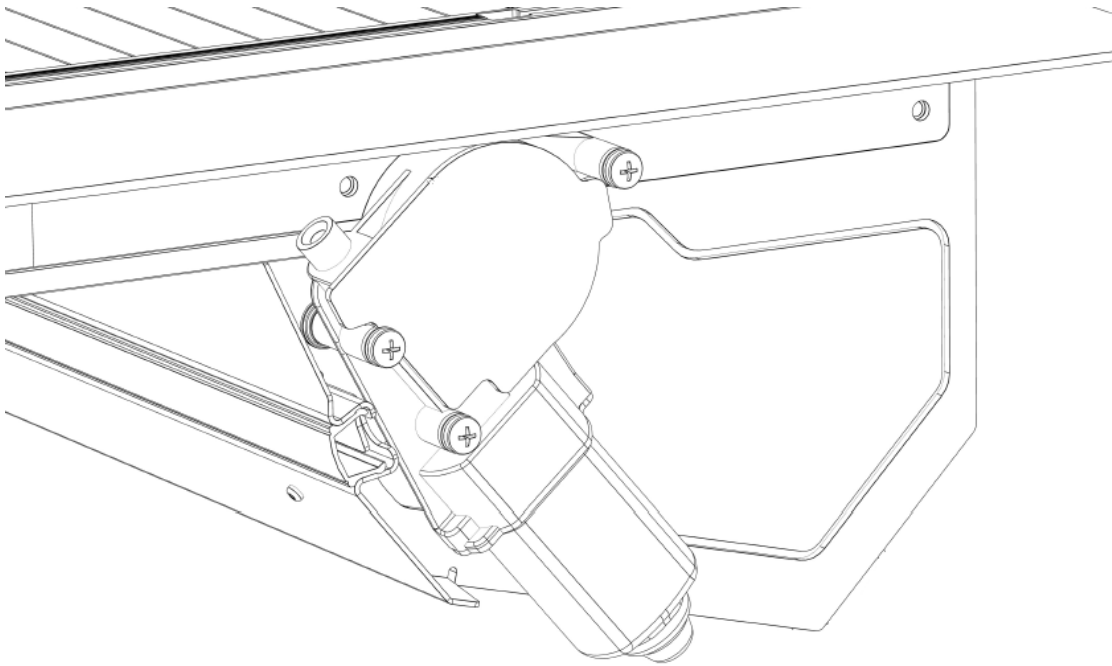

Motor is to sit level.

Any obstructions between motor and canister may cause operating issues.

Apply D-sponge foam tape to side rail as indicated. NOTE: Join foam firmly to the per-fitted foam of the canister. Carefully trim excess off & discard as indicated. Repeat on the other side.

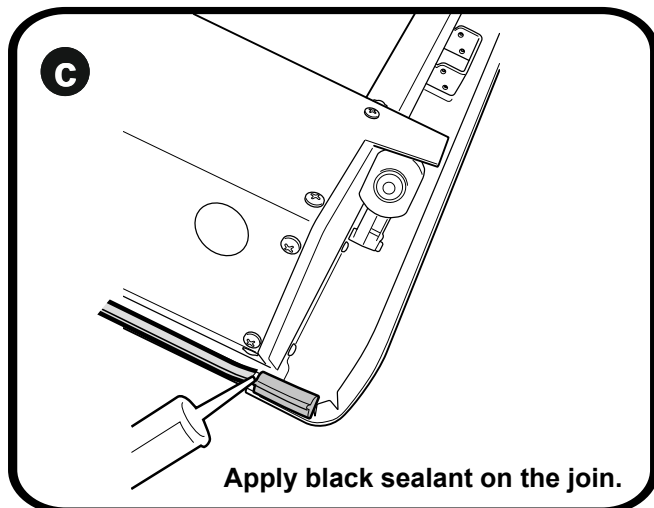
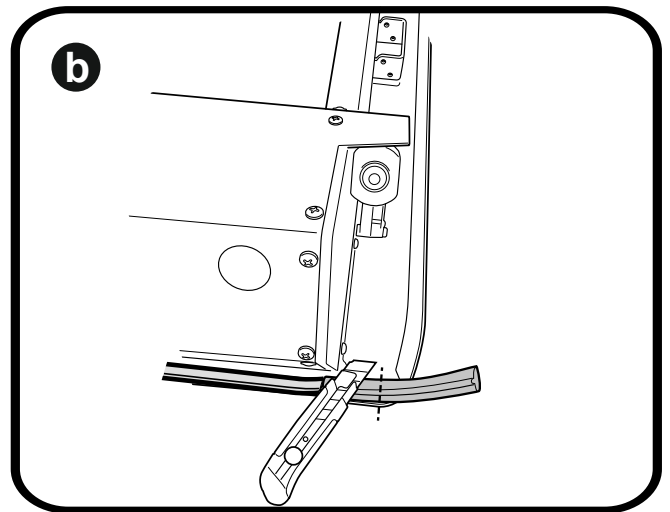
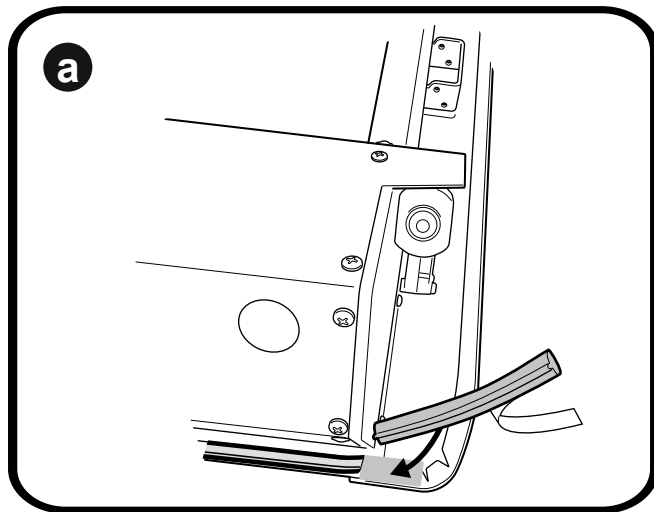

Apply black sealant on the joint.

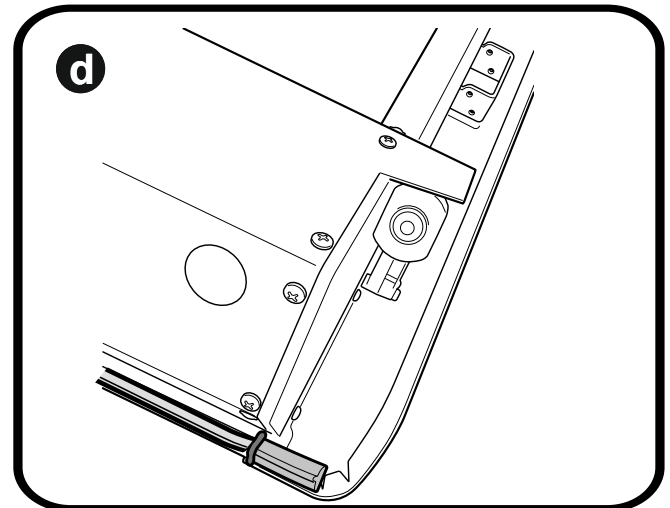

Carefully bring down the assembled unit .

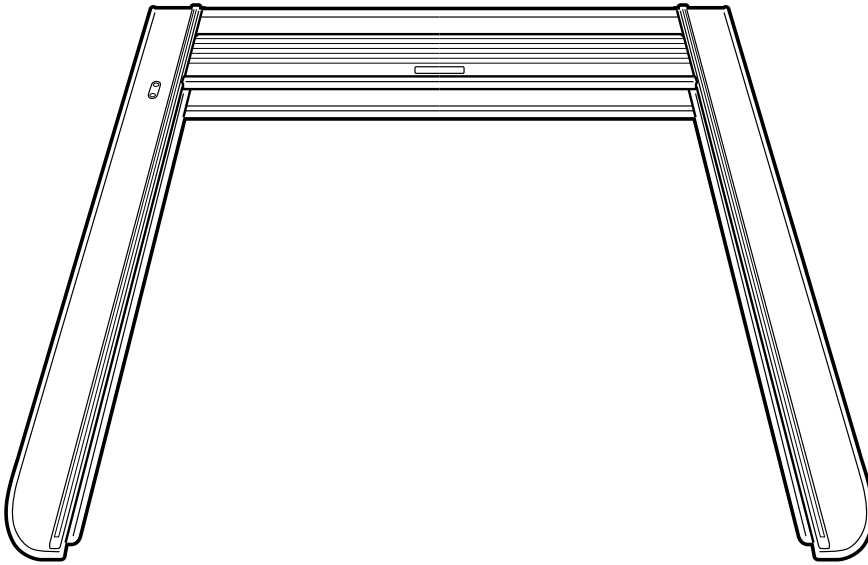

Insert side end caps to the top cover.

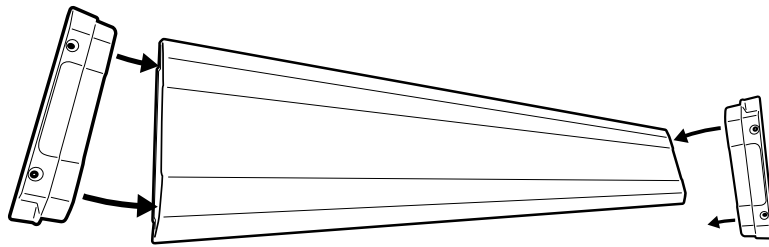

Place & Align top cover over the canister and side rails.

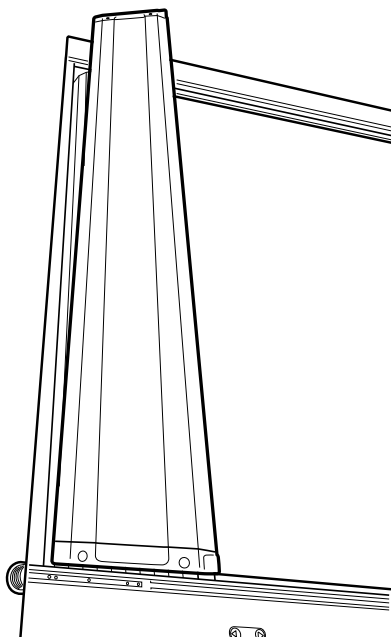

Using countersunk screws provided, line up end cap holes to the threads on the side rail. Fasten to 3nm torque. Repeat to the other side.

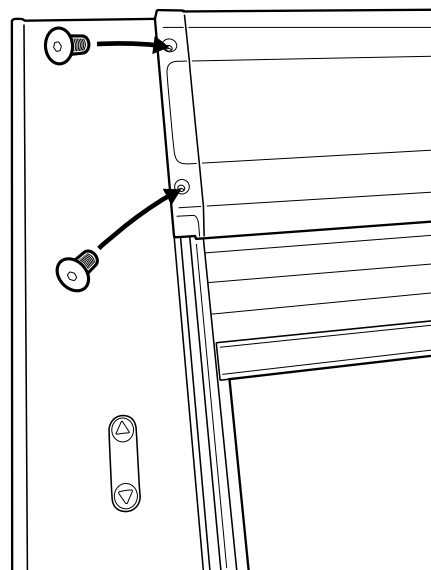

Lay the sail-plain down on a protective mat.

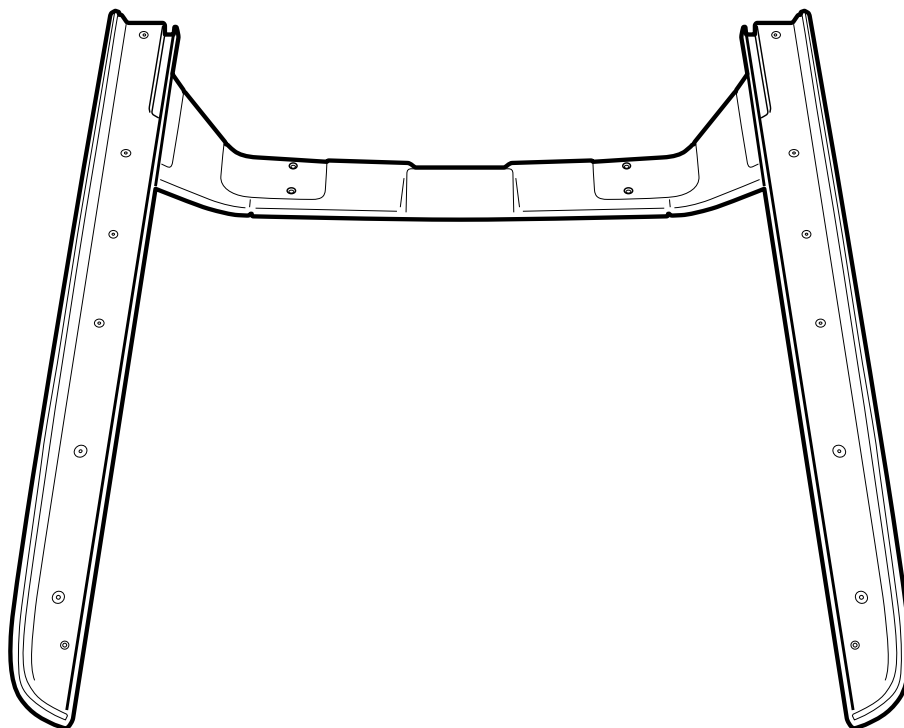

Remove, and discard the front steel bracket on both sides of the sail plane, retain the front two bolts on each side.

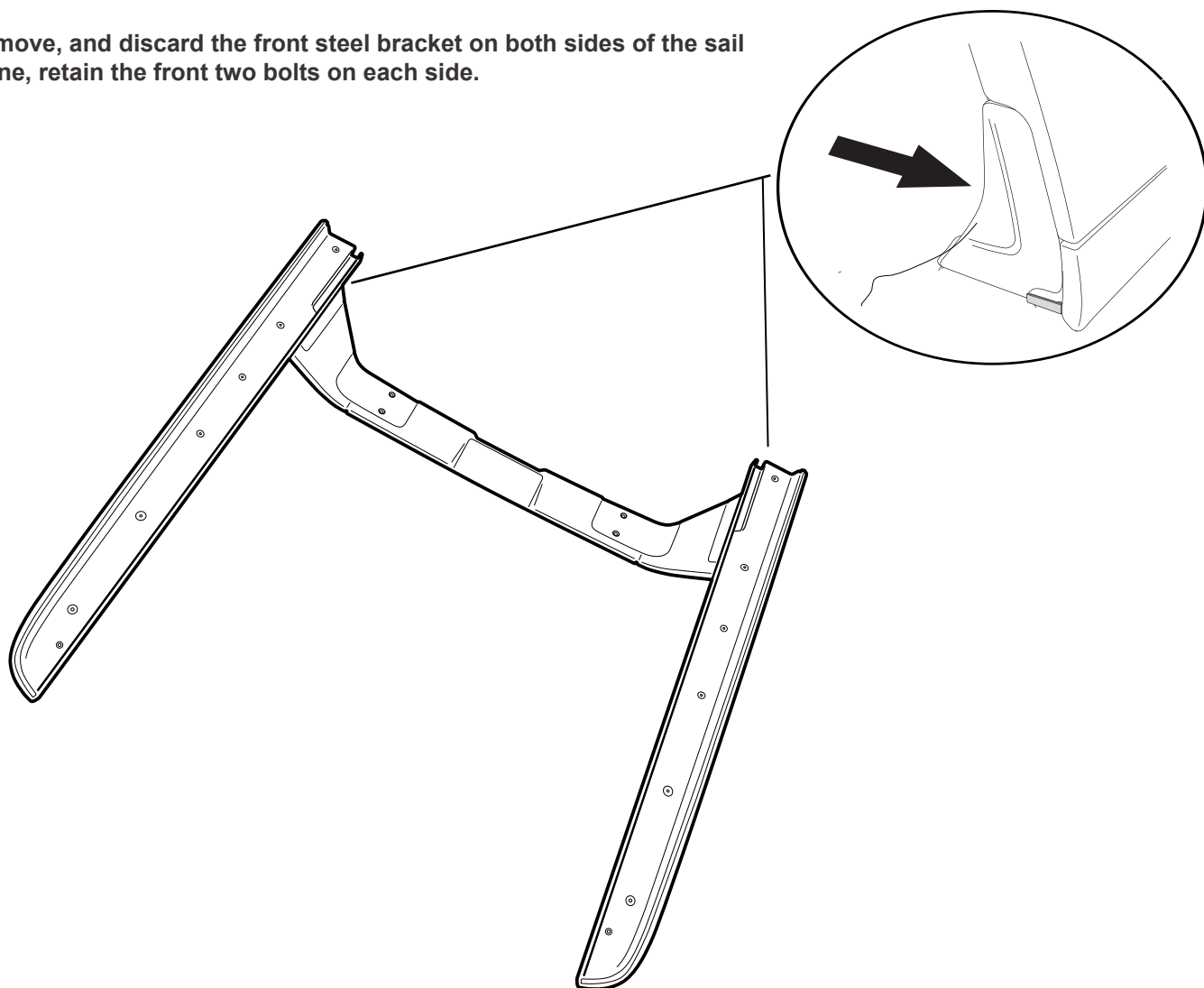

Apply foam tape supplied in the kit as per diagram.

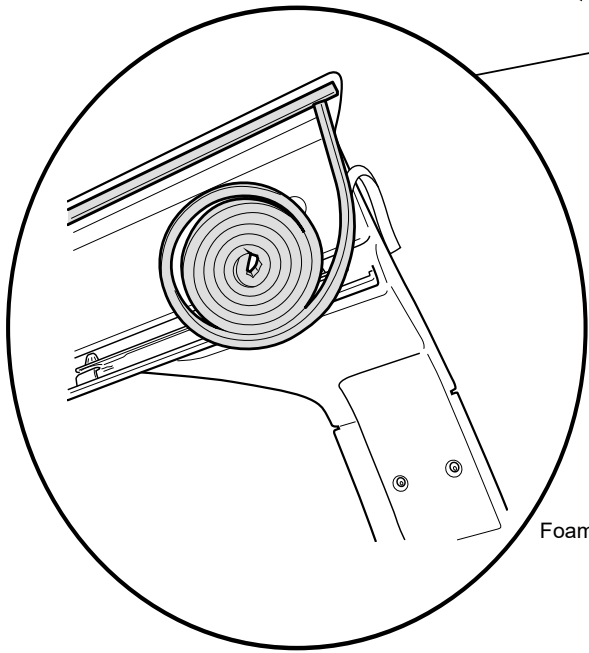

Foam 25mm wide by 5mm thick



Foam 10mm wide by 14mm thick

Keep the existing factory foam on.

Apply the round molded foam tape to the holes of side rails as per diagram.

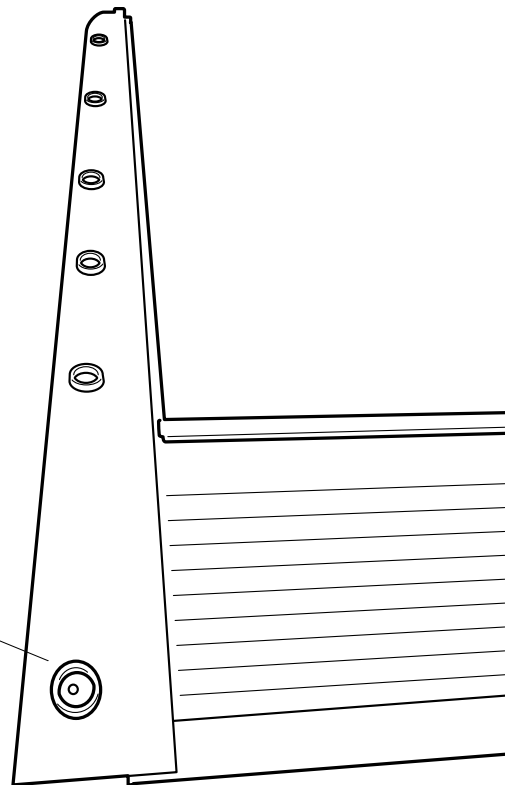
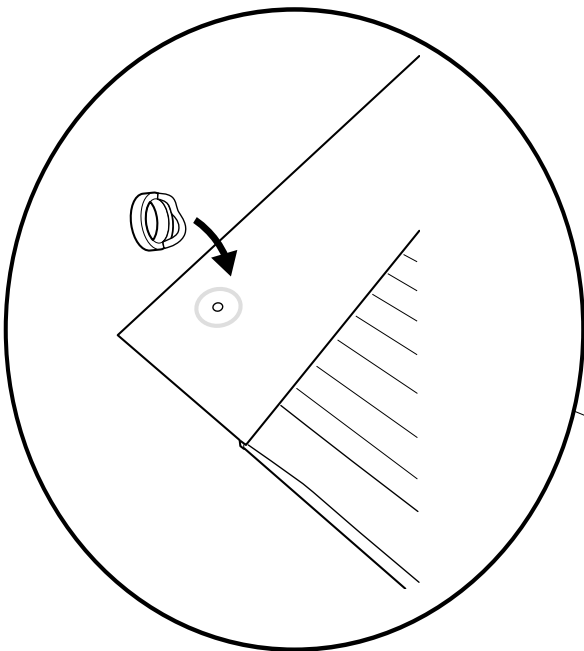

Align the plastic spacers provided in the kit to the center of each hole in the side rail.

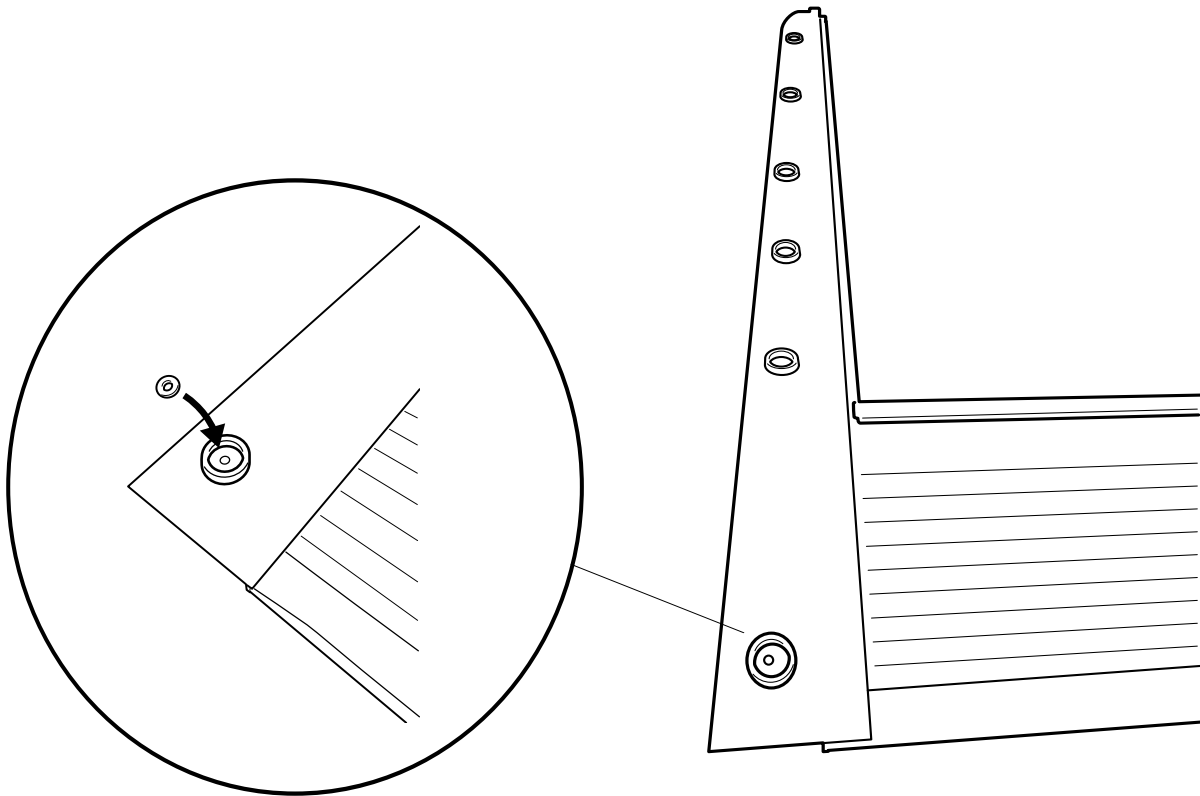

Place the sailplane on to the side rails, lining it up with the holes of the side rail with the thread on the sailplane.

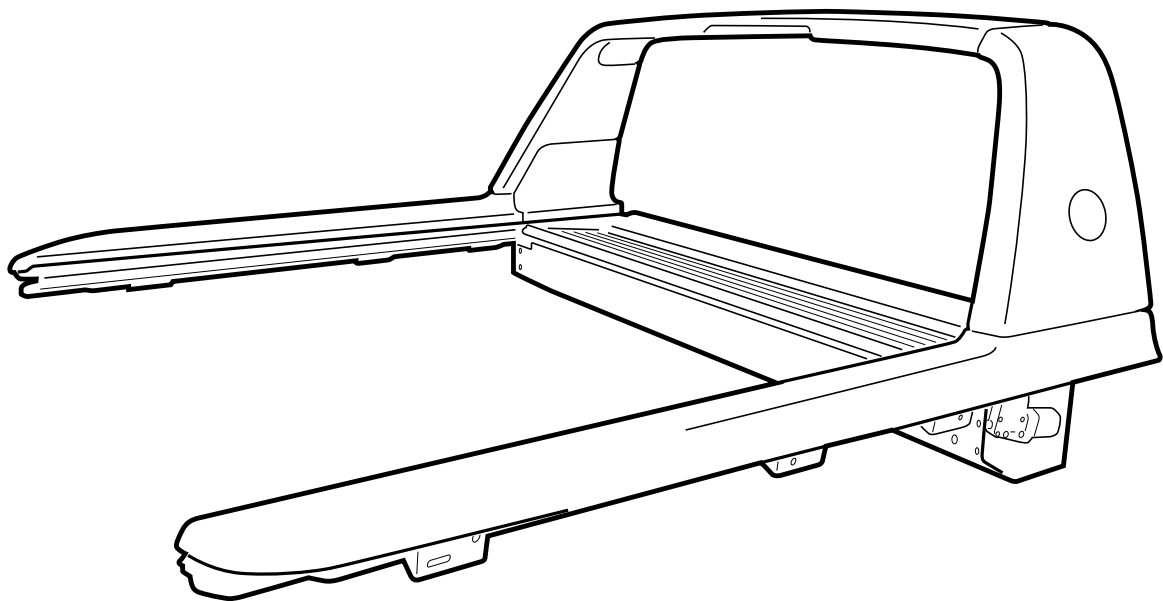

Fasten the sailplane to the side rails using the M6 x 20mm, M6 spring washer & M6 washer provided in the kit.

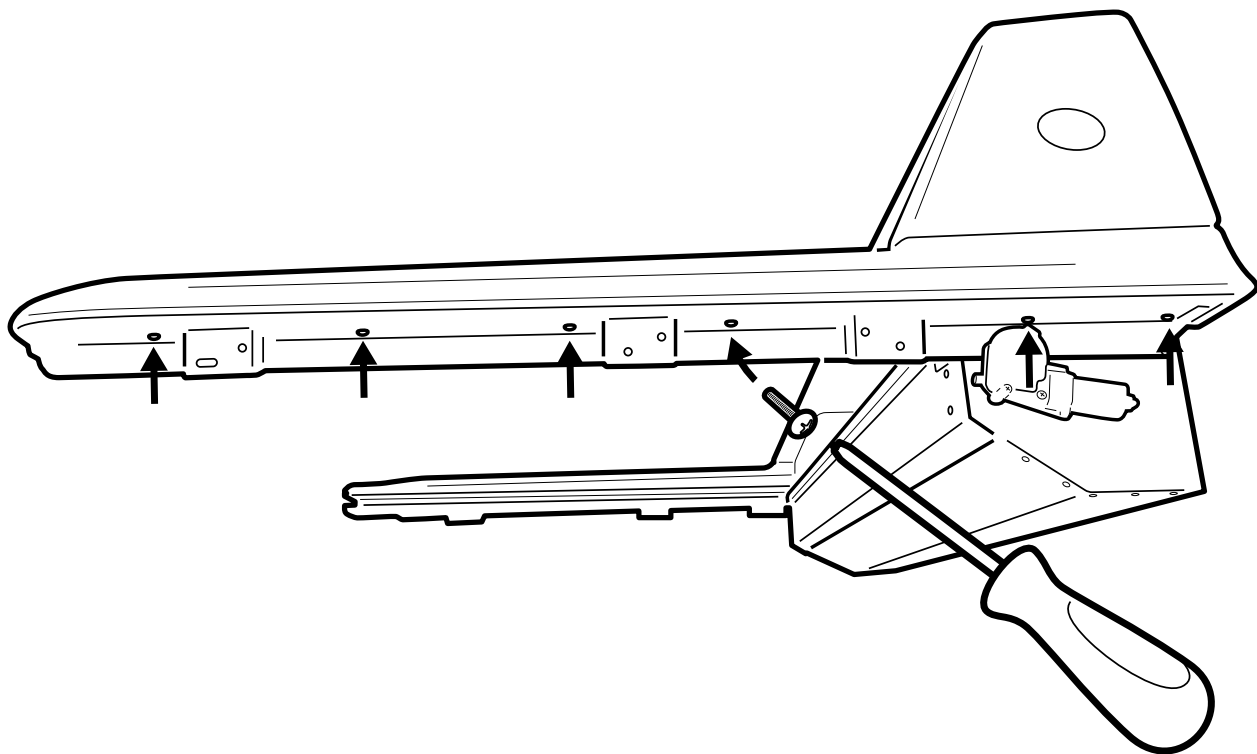

Repeat on other side.

Align the replacement cover provided to the sailplane as per diagram.

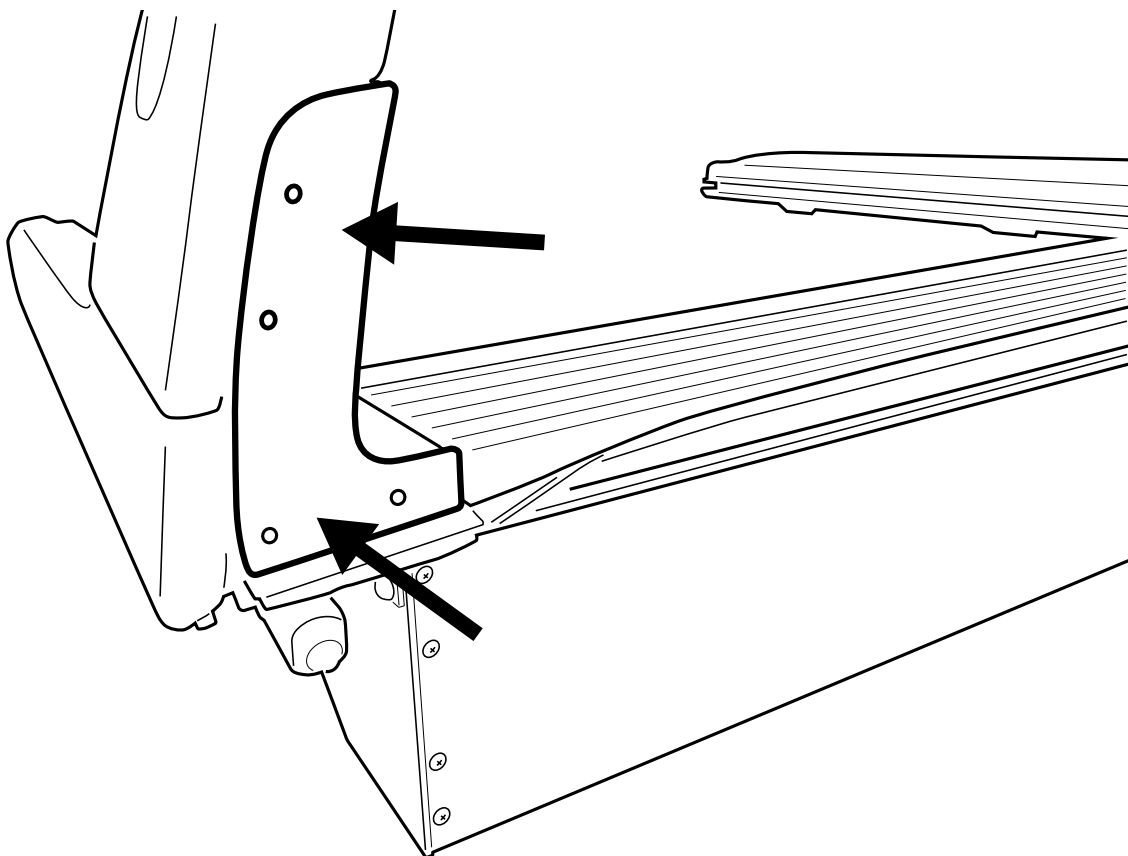

Fasten the top 2 holes using the factory bolts. Repeat to the otherside.

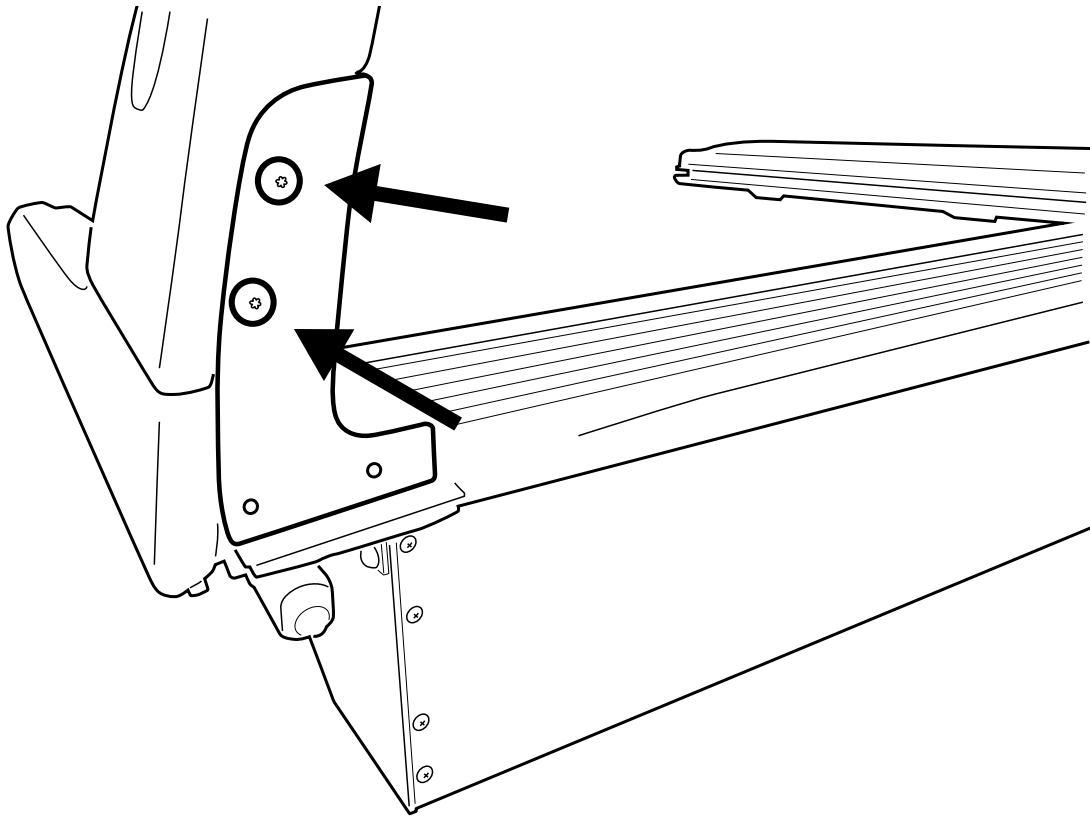

Fasten the bottom 2 holes using the self drilling screws provided. repeat to the otherside.

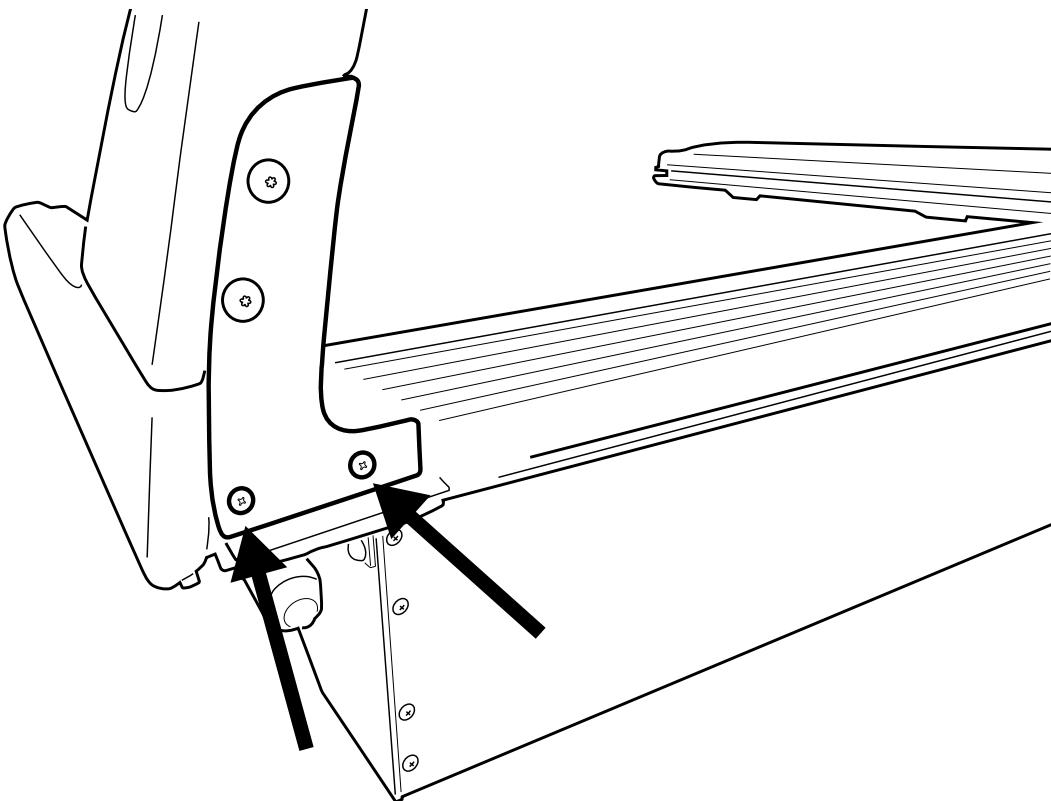

Place the Roll-R-Cover unit on to Ute bed.

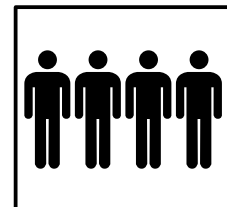
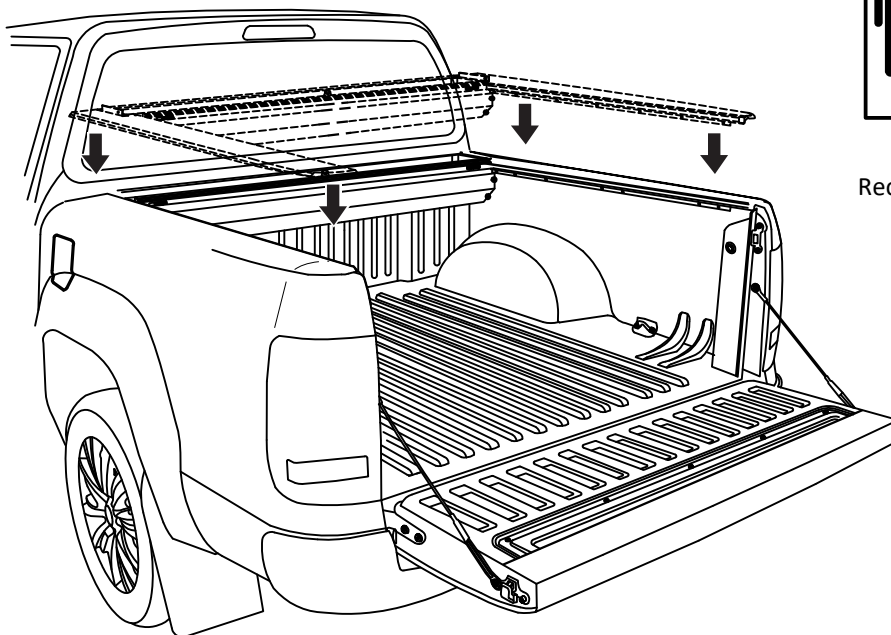

4 People
Recommended for lift

With care, pull out any side rubber that has folded under the side rail.

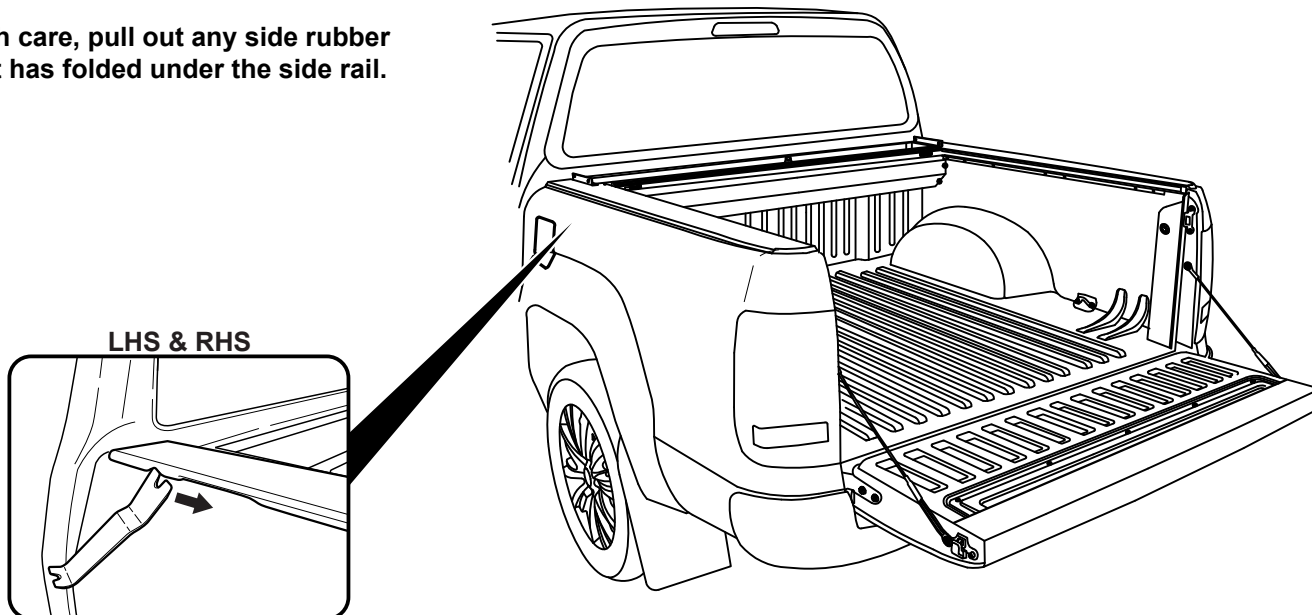

With the tailgate up (Closed position),
Pull left & right hand side rails
towards the tailgate, stopping short by
7mm between tailgate and side-rail
end-cap.

7mm

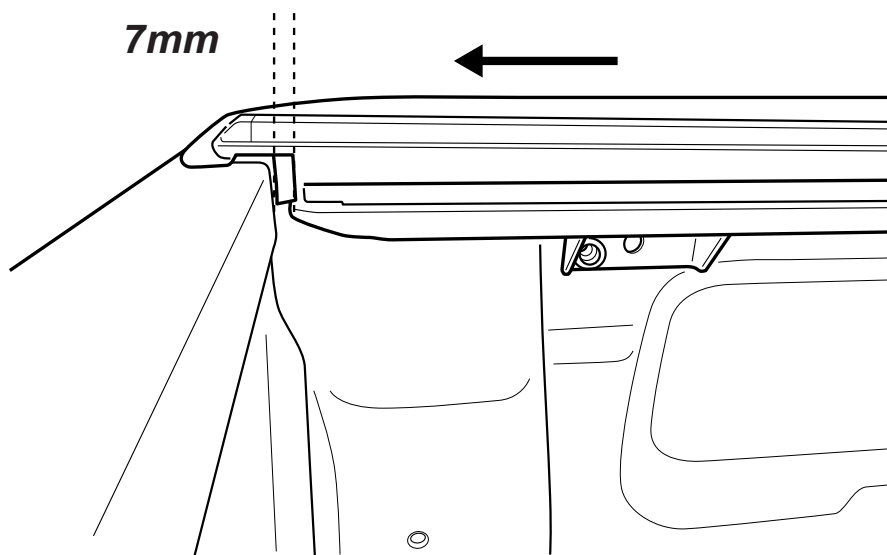

Foam compressed to
5mm when tailgate is
closed.

Gap between tailgate and side-rail end cap to be 7mm.



Foam compressed to 5mm when tailgate is closed.

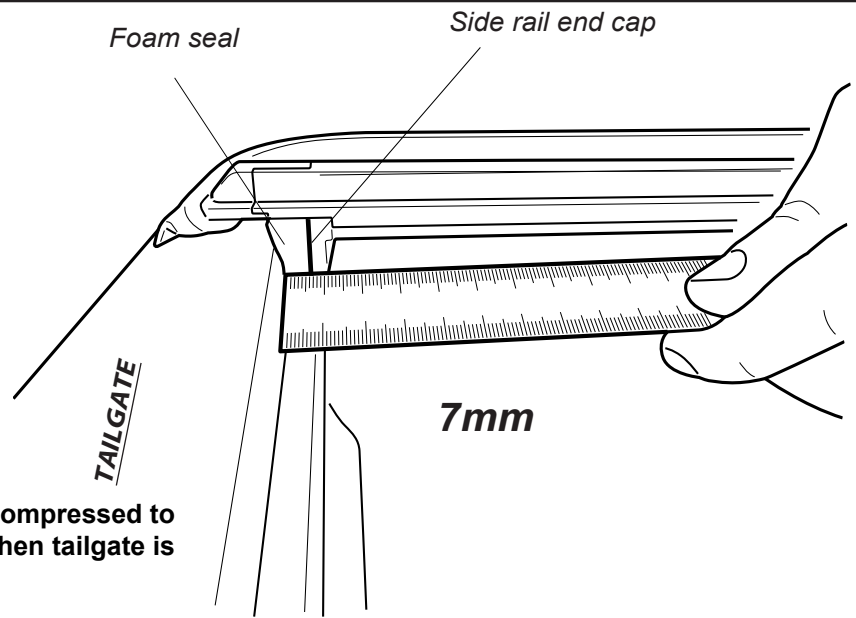

Position clamp behind the inner top lip of the bed rail and the center elongated hole of the side rail mounting brackets. Repeat to all 6 positions.

Ensure the M8 nut is in the indicated slot of the clamp

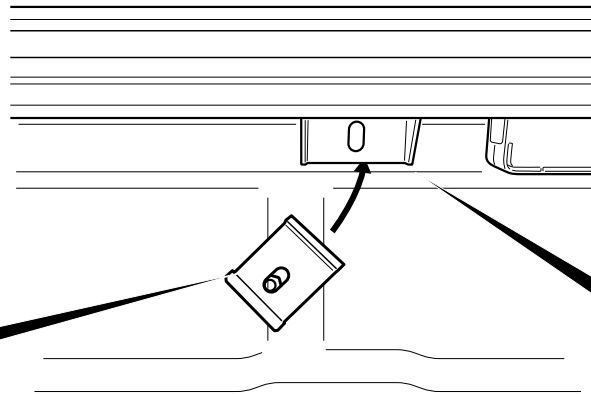
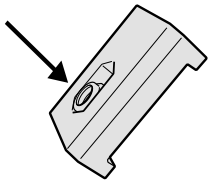

Fasten clamp loosely into position using M8 washer, M8 spring washer and M8 x 35mm bolt.

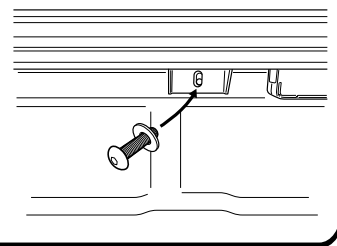

1. Apply pressure on side rails.
2. Lift **clamp** all the way up, then tighten clamp in the order indicated.

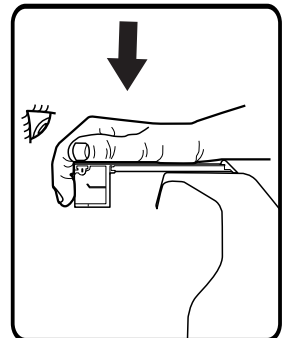
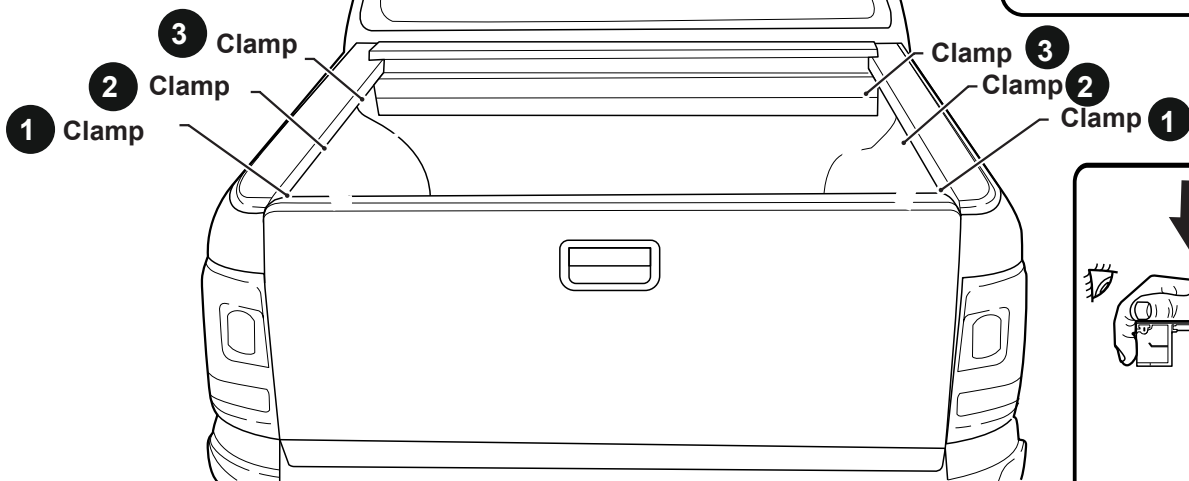
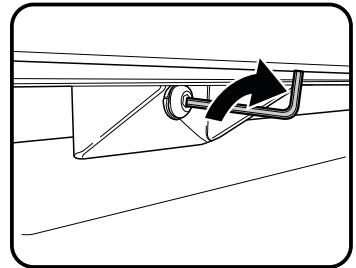

Install front drain pipes through pre-drilled holes of the canister. (RHS/LHS)



Note: With care push tube in.
Taking care pull the tube back
so it seals correctly against
the front panel of the tub.

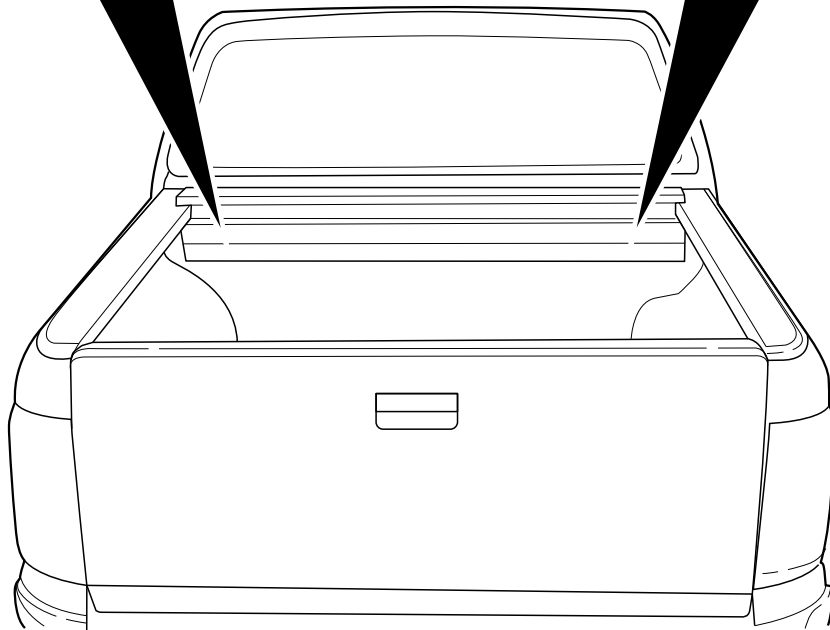
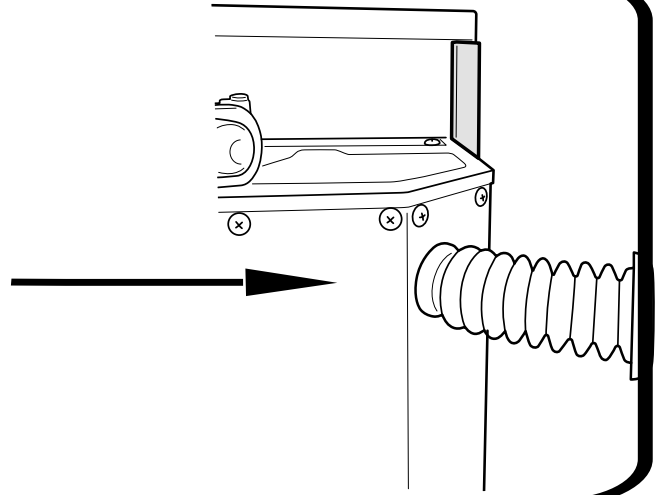
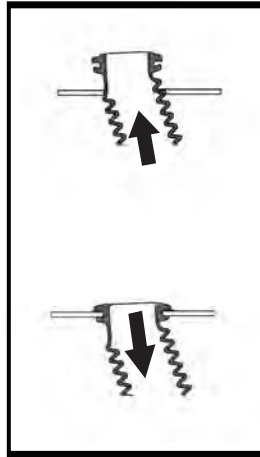

- a. Connect Battery loom S2.75 to Receiver loom.
- b. **Carefully** connect CI-Loom-short to Receiver loom.

 Align connectors carefully to avoid pushing pins out.

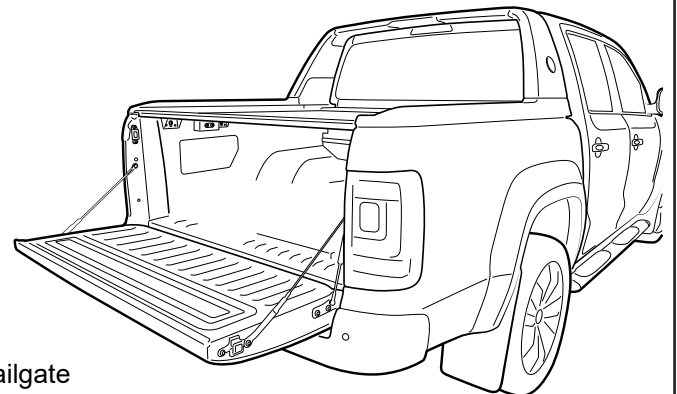
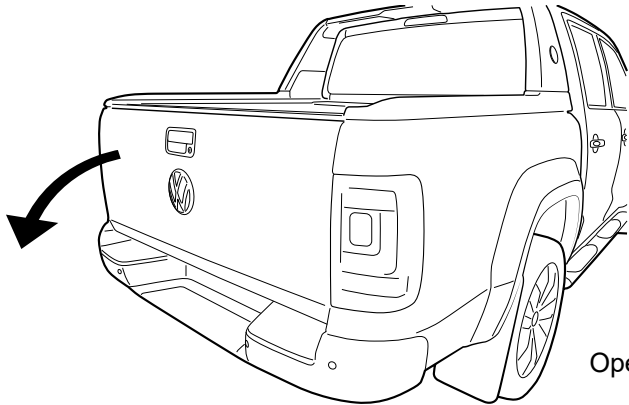
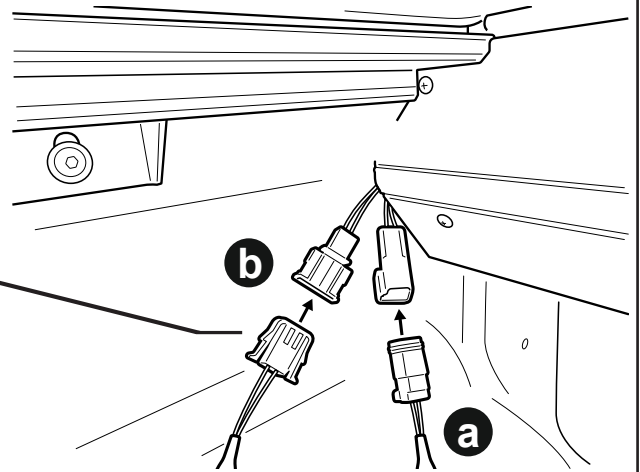

Open the tailgate

Operating instructions:

Press unlock on vehicle key fob to activate controller.
 When vehicle is unlocked the side rail sensor buttons will be active to control.
 When vehicle is locked the side rail sensor buttons will be inactive.

Using factory key fob to operate:

Pressing unlock twice on the factory key fob within 4 seconds, will activate the roll r cover to open. Pressing lock twice on the factory key fob within 4 seconds, will activate the roll r cover to close.

 **Amarok model variation may differ in operation:**

Rolling open: Pressing unlock twice on the factory key fob within 4 seconds, will activate the roll r cover to open.

Rolling closed: Pressing lock followed by unlock followed by lock, on the factory key fob within 4 seconds, will activate the roll r cover to close.

Touch & let go to close, touch & let go again to pause.

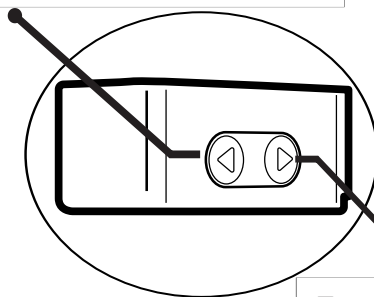

Touch & let go to open, touch & let go again to pause.

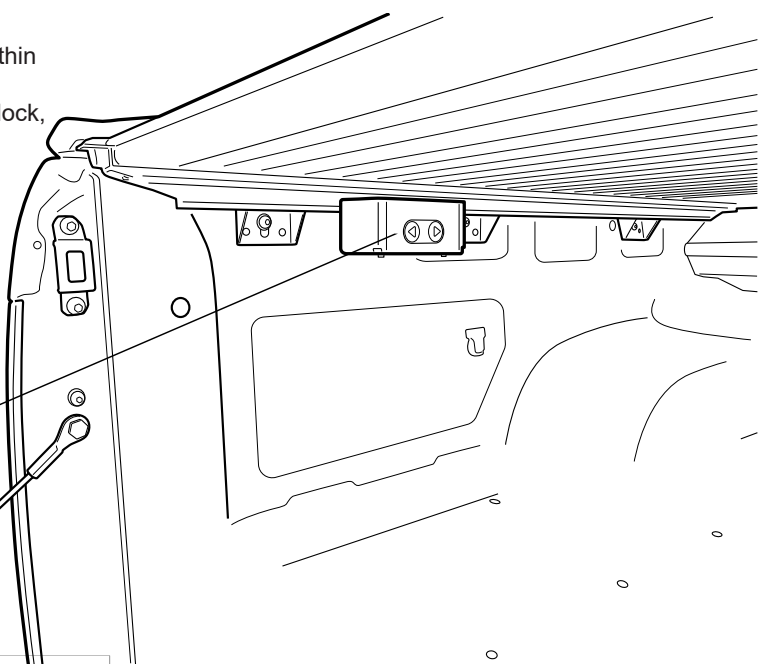

 **NOTE:** 1. To wear in the Roll R Cover please fully open & close the cover approximately 15 times after install is complete.
 2. Set your vehicle locking system to unlock all doors with one press of the factory remote unlock button. This setting can be found in your vehicle settings.