



WWW.HSPUTELIDS.COM

1300 441 498

Part No: A18

Fitting Time: 45mins



VOLKSWAGEN AMAROK

HSP TAIL LOCK

FITTING INSTRUCTIONS

—GENERAL NOTES

- Read through the fitting instructions prior to installation of accessory.
- Ensure all recyclable components and packaging are discarded and recycled following local recycling regulations.
- Safely store and protect any removed vehicle components.

—SAFETY NOTES

- Check that all work practices comply with safety standards.
- Please wear appropriate clothing and use safety equipment.

—FITTING TIME



45mins

—PARTS SUPPLIED

Part Description	Part Number	Quality/ Length	CHECK LIST
TAIL LOCK ASSEMBLY			
Main Bracket	A18-A	1	
Tube	A18-B	1	
Wiring	SHORT-LOOM	1	
Actuator	ACT-01	1	
Patch	A-PATCH	1	
FASTAENERS			
Actuator Screws	36	2	
Spacer	A18-C	1	
M6 20mm	16	1	
OTHER			
Cable Ties		5	
Fitting Instruction		1	

— STEP 1 —

Load tube into actuator striker.

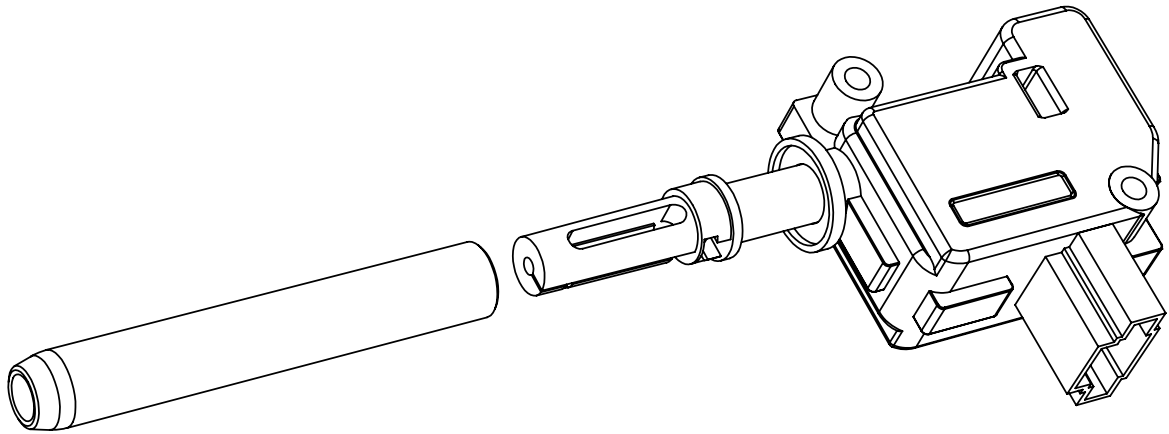

— STEP 2 —

Assemble the actuator using location A with the screws provided as per image .

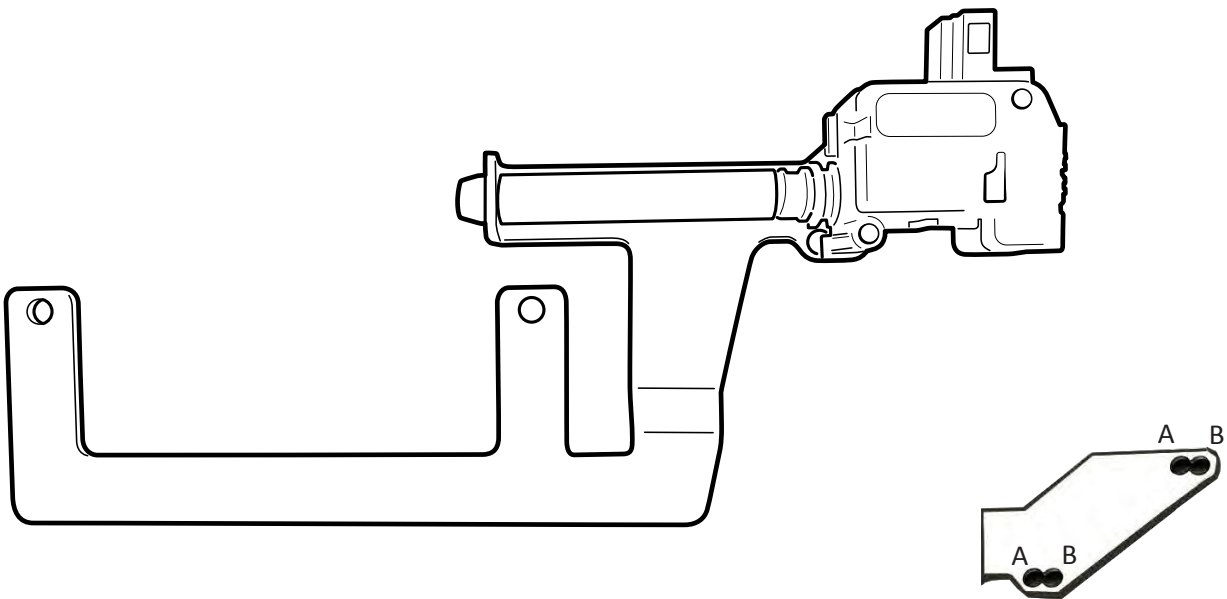

— STEP 3 —

Remove tail gate cover.

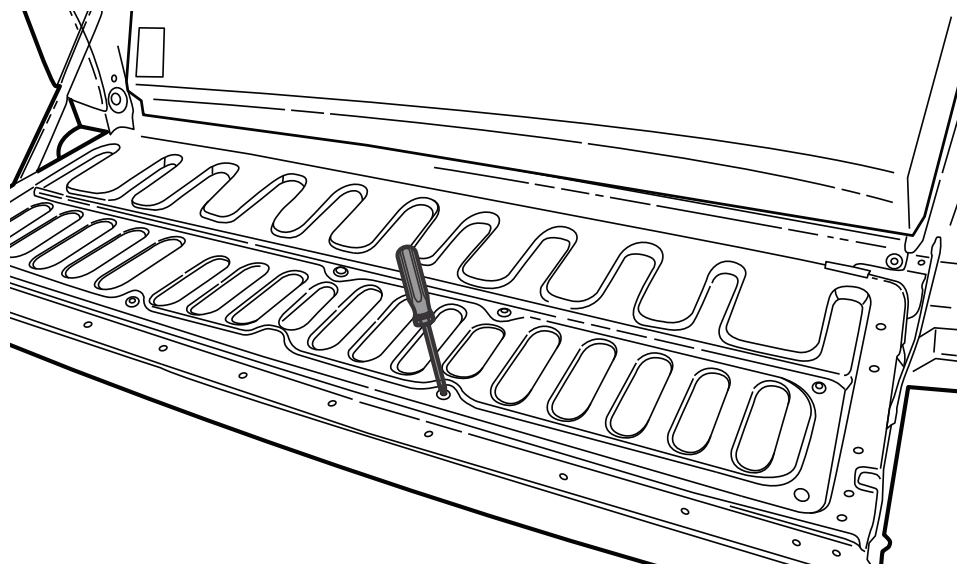

— STEP 4 —

Standard assembly. Unfasten bolts (i) and remove indicated pull to allow for the installation of TailLock.

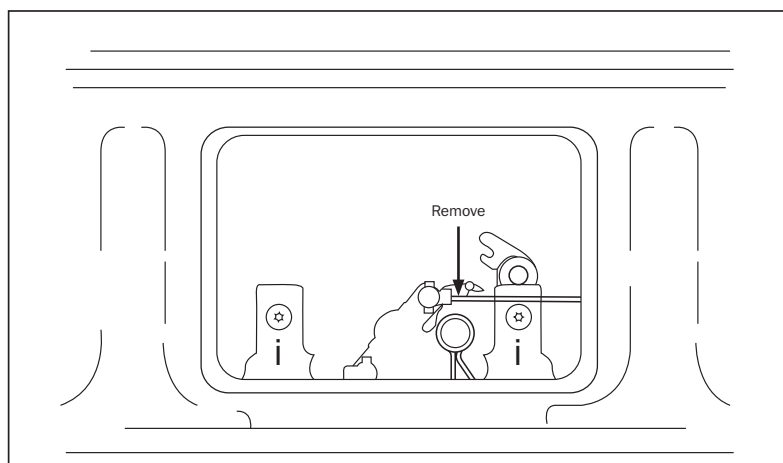

If your Amarok comes without a factory fitted lock barrel on the tailgate, please move on to step 5. (ignoring step 6).
If your Amarok is fitted with a factory lock, please skip step 5.

— STEP 5 —

- 1) Plug wiring to actuator.
- 2) Align the Tail Lock in position and fasten using bolt removed earlier at location (a), fasten location (b) using M6 x20mm bolt followed by A18-A bracket then spacer A18-C.
- 3) Pull Rod to run between and over bracket as shown.

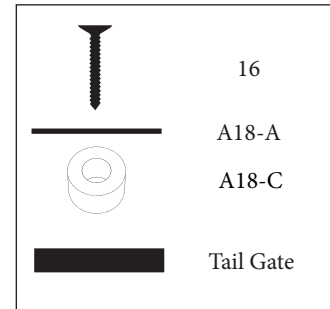
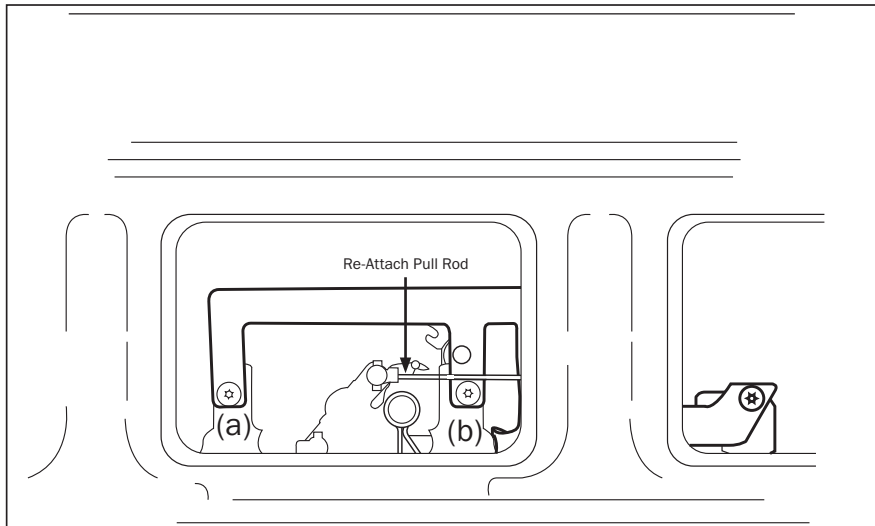

— STEP 6 —

- 1) Plug wiring to actuator.
- 2) Align the Tail Lock in position and fasten using bolts removed earlier.
- 3) Pull Rod to run between and over bracket as shown.

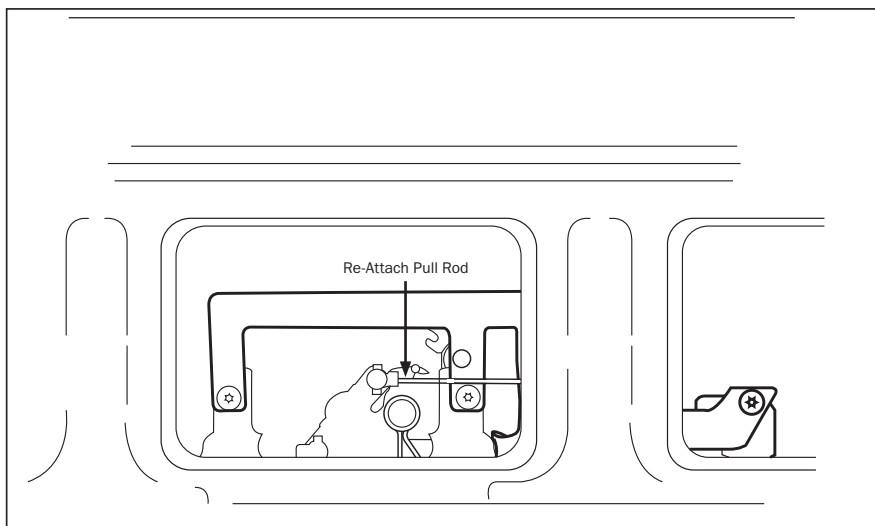

— STEP 7 —

(A) Route the actuator wiring harness (1) out of the tailgate vehicle harness.

and underneath the vehicle following the existing

(B) Route the actuator wiring to the fuel cap plugs next to the wheel arch.

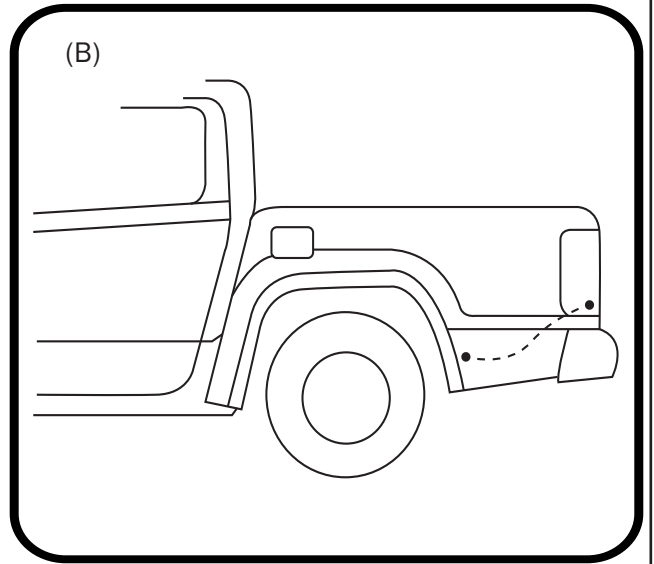
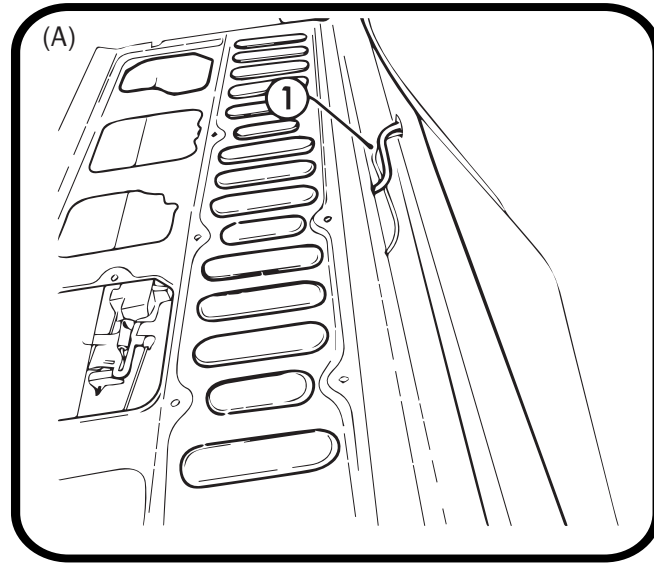

— STEP 8 —

Locate connectors behind rear LHS wheel.

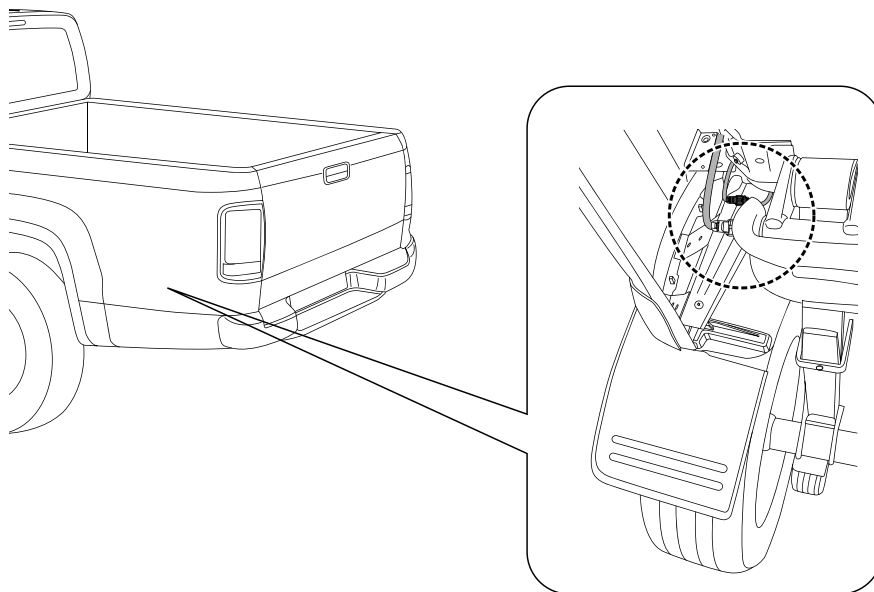

— STEP 9 —

Disconnect the existing vehicle harness connectors under the vehicle as shown.

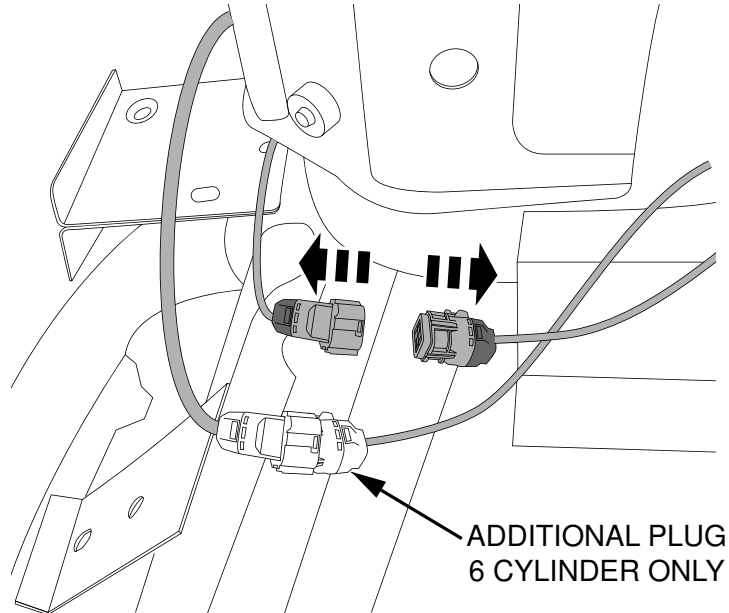

— Step 10 —

Connect the vehicle harness connectors to the previously disconnects connectors to the A-patch supplied. Then connect the A-patch to the CL short loom.

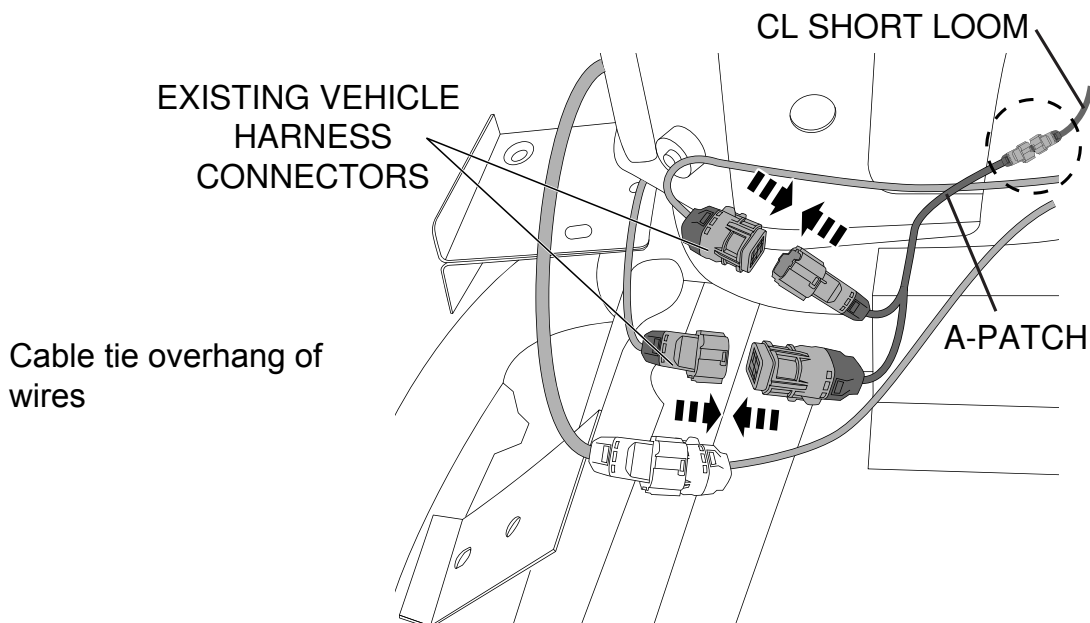

— STEP 10 —

Place and fasten tail gate cover.

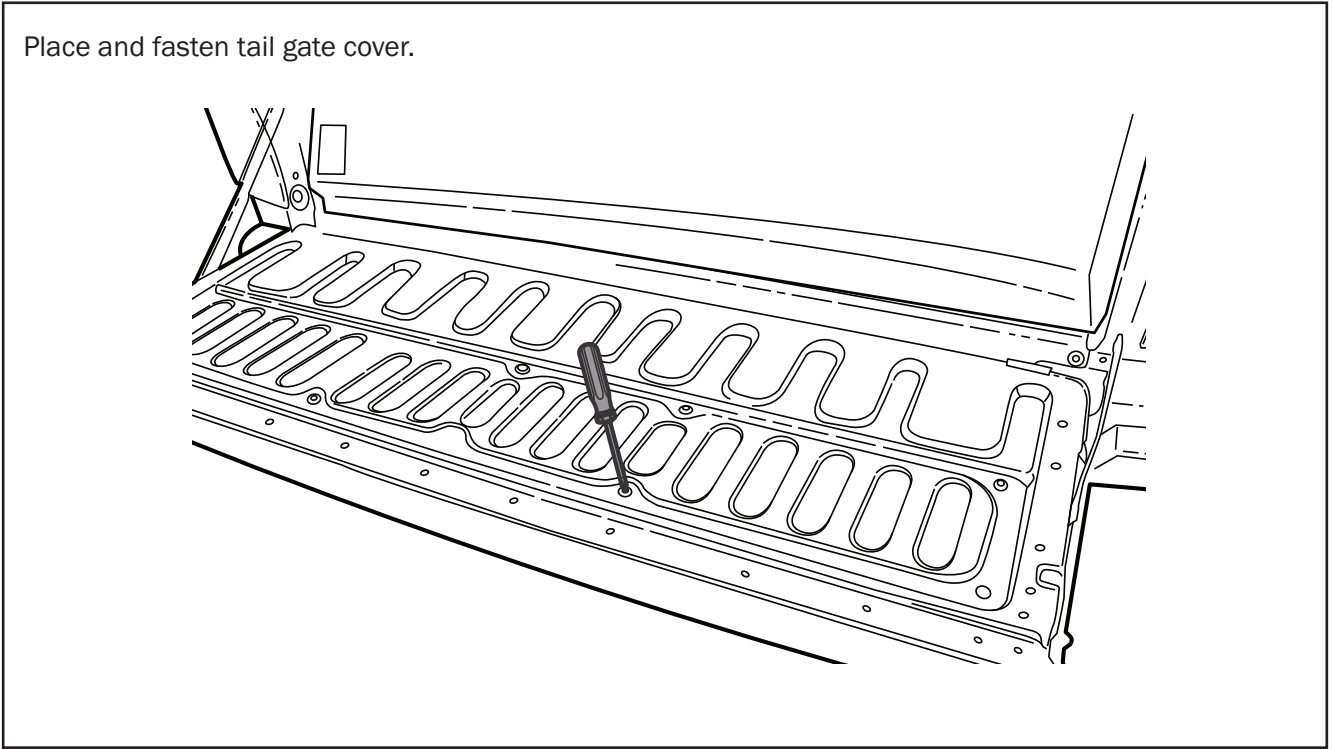

— FITTING COMPLETE —